

Wireless Power Transmission using Class E Power Amplifier from Solar Input

Aravind L
PG Scholar, Dept of EEE
Dayananda Sagar College of Engineering
Bangalore, India

Dr. Usha P
Professor, Dept of EEE
Dayananda Sagar College of Engineering
Bangalore, India

Abstract—The transmission of electrical energy from source to load for a distance without any conducting wire or cables is called Wireless Power Transmission. The concept of wireless power transfer was realized by Nikola Tesla. Wireless power transfer can make a remarkable change in the field of the electrical engineering which eliminates the use conventional copper cables and current carrying wires. Wireless power transmission has been achieved previously by using AC supply or through charged batteries. In this project renewable energy has been used as the source for wireless power transmission. As the output from the renewable energy sources is low, we have to use a suitable step-up converter. The DC output voltage from the solar cell is boosted using a high step-up converter and it is converted to oscillating signals. These oscillating signals are the amplified by using an amplifier and then fed to transmitter coil. By operating at resonant frequency and by achieving good coupling between the transmitter and receiver coil setup, the electrical energy gets transferred from transmitter coil to the receiver coil due to magnetic resonance between them. The transferred energy is converted back to DC using rectifiers and given to the DC load. The proposed wireless power transmission system is validated and verified using MATLAB/SIMULINK.

I. INTRODUCTION

The transmission of electrical energy from source to load for a distance without any conducting wire or cables is called Wireless Power Transmission. Wireless power is necessary where connection of wires is not possible, dangerous and inconvenient. The principle of operation of wireless power transmission was established by Nikola Tesla in the early 1900's. Nikola Tesla invented a resonant transformer known as Tesla coil, which was used to transfer power wirelessly using radiative method. However, Tesla coil produced dangerous high voltage electric arc which was a major concern in terms of safety. The popularity of wireless technology has increased in recent years and also the interest in magnetic power transmission has re-emerged. In the year 2007, the MIT team was able to transfer 60 watts wirelessly over a distance of 2 meters with an efficiency of less than 40% using a 60 cm diameter coil [1].

The wireless transfer of power can be achieved by three ways which are magnetic coupling mode, electric field coupling mode and electromagnetic radiation mode. The magnetic coupling mode is classified into short range electromagnetic induction and mid-range strongly coupled magnetic resonance. The power transferred and the transfer efficiency in the case of electromagnetic induction is high but the distance to which the power is transferred is less. In the case of strongly coupled magnetic resonance method, the

power can be transferred for a longer distance with reduced efficiency when compared to short range electromagnetic induction type. The main principle in the case of electric field coupling mode is the redistribution of the surface charge on any object. The transmitter is excited with a high voltage and high frequency source to generate an alternating electric field which couples with the resonant receiver. The power transferred in this mode is less and the efficiency of the power transfer is largely affected by the surrounding medium. Lastly in the case of electromagnetic radiation, the electric energy is converted into electromagnetic energy such as laser beams or microwaves, which can be radiated over a longer distance. Then received electromagnetic energy is converted back into electric energy. With the increased distance of power transmission in electromagnetic radiation mode, the transfer efficiency is reduced.

The dc-dc converters are mainly used in switch mode regulated power supply and also in dc motor drive applications. These converters have many practical applications, such as solar-cell energy systems, fuel cell energy conversion system, uninterruptable power supply system etc. The DC-DC converter requires large boost conversion from the panel's low voltage to the voltage level of the appliance. Some converters increase turns ratio of the coupled inductor obtain higher voltage than conventional boost converter. Some converters are effective combination fly back and boost converters. They are a range of converters combination developed to accomplish high voltage gain by using coupled inductor technique [2],[4]. Combinations of auxiliary resonant circuit, active snubber synchronous rectifiers, or switched capacitor based resonant circuits and so on, these circuits made active switch into zero voltage switching (ZVS) or zero current switching (ZCS) operation and improved converter efficiency.

The main criterion for achieving wireless power transmission is generation of alternating signals in the transmitter. Often power amplifiers are used to generate these alternating signals, but there is a large power loss associated with power amplifier for wireless power transmission. Et al Sokal in [5] proposed a class E power amplifier which can achieve efficiency up to 100% with higher output power and reduced heat sink requirements.

Fig 1 shows the block diagram of the Wireless Power Transmission System model. It consists of a solar panel which will be used as an input source, whose input voltage will be boosted using a high step-up DC-DC converter. This high voltage is then converted high frequency AC using class E

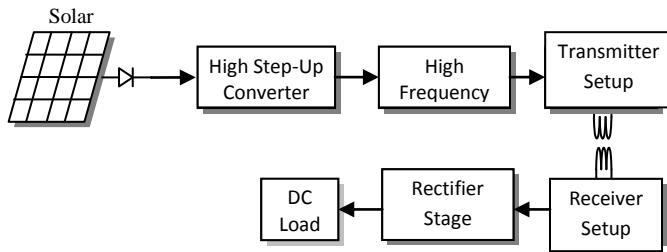

Fig 1, Block diagram of the proposed wireless power transmission system

power amplifiers. The oscillating signals are then fed into the transmitter setup. By achieving proper resonance coupling between the transmitter and the receiver setup power gets transferred wirelessly.

II. DESCRIPTION OF THE PROPOSED WIRELESS POWER TRANSMISSION SYSTEM

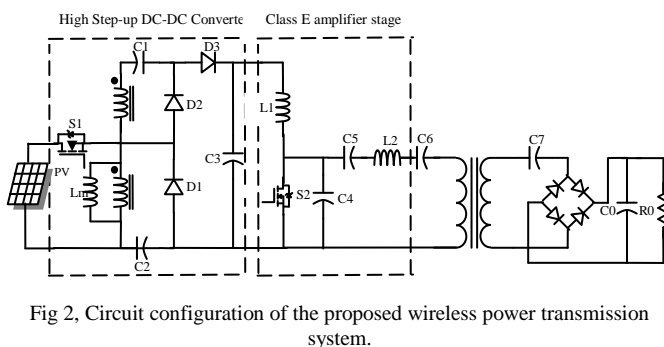

Fig 2, Circuit configuration of the proposed wireless power transmission system.

The fig 2 shows the two main stages of the proposed system. The first stage is the high step-up dc-dc converter which converts the low input voltage from the PV Cell to a higher value. The step-up converter has following advantages:

- I. The converter has a high step-up conversion ratio because of the connection of the coupled inductors, diodes and the capacitors.
- II. It has very high efficiency and lower stress on the switches as the leakage inductor energy can be recycled.

It consists of a coupled inductor T1 with the switch S1. The primary side winding N1 of a coupled inductor T1 is identical to the input inductor of the traditional boost converter, and diode D1, capacitor C1 receives leakage inductor energy from N1. The secondary side winding N2 of coupled inductor T1 is connected with another pair of diode D2 and capacitors C2, which are in series with N1 in order to increase the boost voltage. The rectifier diode D3 is connected to output capacitor C3.

The second stage is the class E amplifier which receives the dc input from the high step-up converter and converts to high frequency ac. The class E amplifier is a high efficient switch mode resonant converter. The high efficiency results from the reduced power losses in the transistor. The higher efficiency of the switch can be achieved by:

- I. Using the transistor as a switch to reduce the power
- II. Reducing the switching losses which result from finite transition time between ON and OFF states of the transistor.

The Class E amplifier consists of a RF choke L1 and a parallel-series resonator circuit consisting of C4, C5 and L2.

The output of the class E power amplifier is connected to the tank circuit formed by C6 and the transmitting coil as shown in the fig 2.

The receiver consists of a tank circuit formed by capacitor C7 and the receiving coil and a simple full bridge diode rectifier to convert the ac power transmitted from the transmitter coil to dc and a filter C0 is used to reduce the harmonics and then given to the load R0. The power gets transferred resonant frequency is achieved between transmitter and receiver pair.

III. MODES OF OPERATION OF THE PROPOSED WIRELESS POWER TRANSMISSION SYSTEM

There are five modes of operation for high step-up dc-dc converter and class E amplifier has only two modes which will be discussed separately.

A. Modes of Operation of High Step-Up DC-DC Converter:

Mode I ($t_0 - t_1$): Fig 3 shows the mode I operation of the step-up converter. When the switch S1 is closed, the capacitor C2 gets completely charged by the magnetizing inductor L_m . The magnetizing inductor current I_{Lm} decreases as the input voltage V_{in} crosses the magnetizing inductor L_m and the leakage inductor L_{k1} . L_m still continues to transfer energy to the capacitor C2 but this energy is decreasing. The current through the diode D2 and the capacitor C2 are also decreasing. The secondary leakage current i_{Lk2} is also decreasing with a slope of i_{Lm}/n . This mode ends when increasing i_{Lk1} is equal to the decreasing i_{Lm} at $t=t_1$.

Mode II ($t_1 - t_2$): Fig 4 shows the mode II operation of the step-up converter. During this mode, the input source voltage V_{in} gets series connected with N2, C1 and C2 which charge the output capacitor C3. The currents i_{Lm} , i_{Lk1} and i_{d3} increases as V_{in} crosses L_{k1} , L_m and N1. L_m and L_{k1} stores energy from V_{in} also C1 and C2 discharge their energy to C3. Hence i_{d3} and the discharging currents i_{c1} and i_{c2} also increase. The switch is turned off at $t=t_2$ and this mode ends.

Mode III ($t_2 - t_3$): Fig 5 shows the mode III operation of the step-up converter. During this mode the secondary leakage inductor L_{k2} keeps charging the output capacitor C3 when the switch is turned off at $t=t_2$. Diodes D1 and D3 will be conducting. The stored energy in L_{k1} flows through D1 to charge the capacitor C1. Also, the stored energy in the leakage inductor L_{k2} is in series with C2 to charge the output capacitor C3. Since the inductances of L_{k1} and L_{k2} are very small compared to L_m , i_{Lk2} decreases rapidly but i_{Lm} increases as the magnetizing inductor L_m receives energy from L_{k1} . This mode ends when i_{Lk2} decreases and reaches zero at $t = t_3$.

Mode IV ($t_3 - t_4$): Fig 6 shows the mode IV operation of the step-up converter. The magnetizing inductor L_m discharges its energy to C1 and C2. Diodes D1 and D2 are conducting in this mode. The currents i_0 and i_{D1} are decreases continuously as the leakage energy charge the capacitor C1 through the diode D1. The magnetizing inductor L_m discharges its energy to charge the capacitor C2 through T1 and D2. The energy stored in C3 is continuously discharged to the load R. These energy transfers decreases the currents i_{Lk1} and i_{Lm} but increases the current i_{Lk2} . This mode ends when i_{Lk1} reaches zero at $t=t_4$.

Mode V ($t_4 - t_5$): Fig 7 shows the mode V operation of the step-up converter. During this mode of operation, L_m continuously discharges its energy to C_2 and diode D_2 will be conducting. The current i_{L_m} decreases as it charges the capacitor C_2 through T_1 and D_2 . This mode ends when the switch S_1 is turned on at the beginning of the next switching period.

B. Modes of Operation of Class E Power Amplifier:

Fig 8 shows the two switching stages of the switch S_1 which is ON for a half cycle and off for another half cycle. The switch S_1 is turned ON at zero drain voltage and zero drain current to reduce the switching losses when the transistor is turned ON.

Optimum Operation Mode: When the switch is turned OFF, there will be a jump change in the drain current but the drain voltage starts to increase slowly from zero thus reducing the switching losses. This will be the optimum mode of operation of class E amplifier as ZVS and ZCS has been achieved which provides the highest efficiency.

Sub-Optimum Operation Mode: Class E amplifier can be operated in a sub-optimum operation mode, where the capacitor C_1 connected across the switch S_1 is discharged to zero before turning ON the switch S_1 by proper gate signals. In this case the drain voltage becomes negative and the anti-parallel diode of the switch S_1 conducts only the negative current and maintains the drain voltage close to zero before the switch S_1 is turned ON, thus reducing the switching losses.

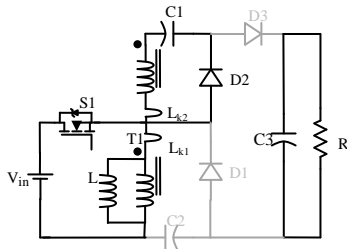

Figure 3, Mode I operation of high step-up dc-dc converter

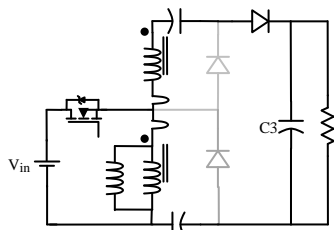

Figure 4, Mode II operation of high step-up dc-dc converter

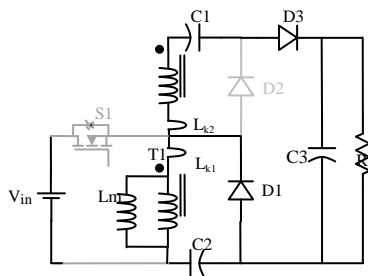

Figure 5, Mode III operation of high step-up dc-dc converter

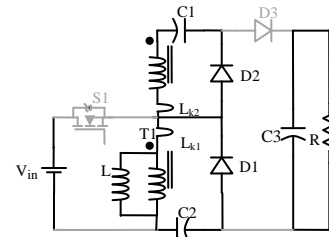

Figure 6, Mode IV operation of high step-up dc-dc converter

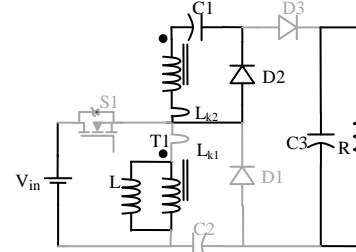

Figure 7, Mode V operation of high step-up dc-dc converter

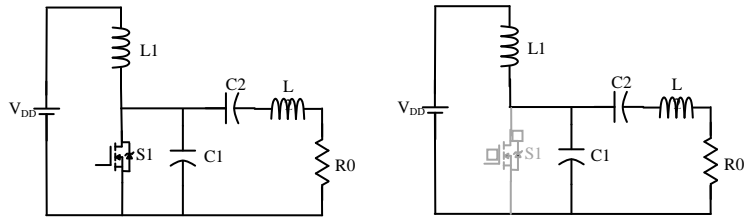

Figure 8, Operation of Class E Power Amplifier

IV. DESIGN OF THE PROPOSED WIRELESS POWER TRANSMISSION SYSTEM

The design of the proposed WPT system requires the design of the high step-up dc-dc converter and the design of the class E power amplifier. Hence, there are two design stages which will be discussed in this section. During the design procedure, following assumptions are made:

- I. All the components are assumed to be ideal
- II. The ON state resistance and the parasitic capacitance of the switches are neglected.
- III. The voltage drops across the diodes are neglected.
- IV. The capacitors are assumed to have a very large value.

A. High Step-Up DC-DC Converter Design:

- Input Voltage $V_{in} = 12\text{ V}$ (1)
- Output Voltage $V_0 = 70\text{ V}$ (2)
- Switching frequency $f = 100\text{ KHz}$ (3)
- Transformer turns ratio $n = 2$ (4)
- Output $R = 100\ \Omega$ (5)

Now the duty cycle D is calculated as

$$D = 1 - \frac{V_{in}(1+n)}{V_0} \tag{6}$$

$$D = 1 - \frac{12(1+2)}{70} \tag{7}$$

$$D = 0.485 \text{ or } 48.5\% \tag{7}$$

The boundary normalized magnetizing time constant τ_{LB} is depicted as,

$$\tau_{LB} = \frac{D(1-D)^2}{2(1+n)^2} \tag{8}$$

At the boundary for converter's operation at 50% of the full load, the load resistance $R=200\ \Omega$ is selected. Substituting the value of D in the equation 4.8, we have

$$\tau_{LB} = \frac{0.485(1-0.485)^2}{2(1+2)^2}$$

$$\tau_{LB} = 7.1371 \times 10^{-3} \text{ s} \quad (9)$$

Now the boundary magnetizing inductance is found as,

$$L_{mB} = \frac{\tau_{LB} R}{f} = \frac{7.1371 \times 10^{-3} \times 100}{50 \times 10^3}$$

$$L_{mB} = 14.275 \mu\text{H} \quad (10)$$

Hence the magnetizing inductance L_m has to be greater than the boundary magnetizing inductance L_{mB} i.e., $L_m > 14.275 \mu\text{H}$ (11)

B. Class E Transmitter Design:

To start with we have to first set the supply voltage of the class E power amplifier by using the equation.

$$V_{CC} = \frac{BV_{CEV}}{3.56} \cdot SF \quad (12)$$

Where BV_{CEV} is the breakdown voltage of the MOSFET which is to be used and SF is the safety factor whose value is not greater than 1. Assuming SF to be 0.8 and the supply voltage of 70 V, we have

$$BV_{CEV} = \frac{3.56 \times V_{CC}}{SF}$$

$$= \frac{3.56 \times 70}{0.8} = 311.5$$

i.e. we have to choose a MOSFET whose breakdown voltage has to be greater than 311.5V.

Based on the power specification and Q_L , the load resistance can be calculated based on the following equation as shown in 14.

$$R_L = \frac{(V_{CC})^2}{P_{Out}} \cdot 0.576801 \left(1.001245 - \frac{0.451759}{Q_L} - \frac{0.402444}{Q_L^2} \right) \quad (14)$$

Where the value of Q_L is chosen by the designer, for a duty cycle of 50%, the minimum value of Q_L is 1.7879. In [8] the value of Q_L is chosen to be 2.134 and P_{Out} as 60 W, we have

$$R_L = \frac{(70)^2}{60} \cdot 0.576801 \left(1.001245 - \frac{0.451759}{2.134} - \frac{0.402444}{2.134^2} \right)$$

$$R_L = 32.98 \Omega$$

Hence the value of R_L is chosen to be $R_L = 50 \Omega$

The next step is to calculate the value of the shunt capacitance C_1 which is to be connected across the switch by the following equation.

$$C_1 = \frac{1}{2\pi f_o R_L \left(\frac{\pi^2}{4} + 1 \right)^{\frac{1}{2}}} \left(0.99866 + \frac{0.91424}{Q_L} - \frac{1.03175}{Q_L^2} \right) + \frac{0.6}{(2\pi f_o)^2 L_1} \quad (15)$$

$$C_1 = \frac{1}{34.2219 f_o R_L} \left(0.99866 + \frac{0.91424}{Q_L} - \frac{1.03175}{Q_L^2} \right) + \frac{0.6}{(2\pi f_o)^2 L_1} \quad (16)$$

We have chosen the operating frequency of 13.56 MHz, substituting the value of f_o and R_L in the equation 16, we have the value of shunt capacitance C_1 as

$$C_1 = 51.74 \text{pF} + \frac{0.6}{(2\pi f_o)^2 L_1} \quad (17)$$

Usually the value of X_{L1} is chosen to be 30 or more than times the unadjusted value of X_{C1} .

$$\text{i.e. } X_{L1} > 30 \times X_{C1} \quad (18)$$

$$\omega L_1 > \frac{30}{\omega C_1}$$

$$L_1 > \frac{30}{\omega^2 C_1}$$

Substituting the value of C_1 as 51.74pF and $f_o = 13.56\text{MHz}$, we have

$$L_1 > 79.87 \mu\text{H}$$

The value of L_1 is chosen to be $80 \mu\text{H}$. Substituting this value of L_1 in equation 17, the value of shunt capacitance C_1 is found to be

$$C_1 = 79.4 \text{pF}$$

The value of C_2 is calculated by using the equation below

$$C_2 = \frac{1}{2\pi f_o R_L} \left(\frac{1}{Q_L - 1.04823} \right) \left(1.00121 + \frac{1.01468}{Q_L - 1.7879} \right) - \frac{0.2}{(2\pi f_o)^2 L_1} \quad (19)$$

Substituting the value of f_o , R_L and Q_L in the equation 19, we have

$$C_2 = 689.9127 \text{pF}$$

The value of L_2 is found from the equation below

$$L_2 = Q_L \frac{R_L}{2\pi f_o} \quad (20)$$

Substituting the value of f_o , R_L and Q_L in the equation 20, we have

$$L_2 = 0.8 \mu\text{H}$$

V. SIMULATION AND RESULTS

The simulation of the proposed wireless power transmission model has been carried out using MATLAB/SIMULINK. The proposed model has been verified for an input voltage of 12V from the solar panel and the output is obtained to be 110V.

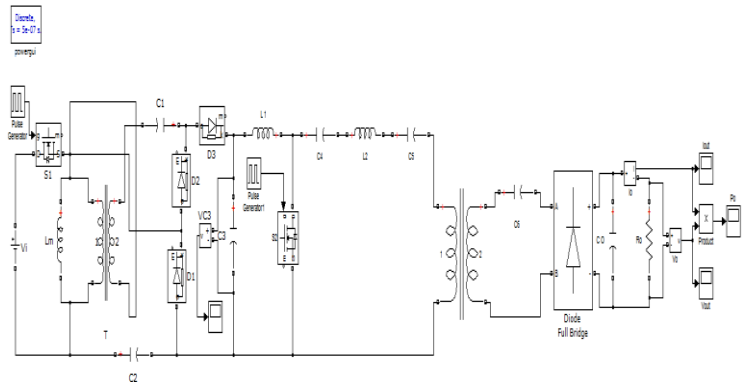

Figure 9, Circuit arrangement of the proposed wireless power transmission system using MATLAB/SIMULINK package.

The specifications of various components used in the proposed model are tabulated below.

Sl no.	Parameter	Value
1	Lm	15μH
2	C1	47μF
3	C2	47μF
4	C3	470μF
5	Duty ratio of S1	48.5%
6	Turns ratio of T1	2
7	L1	80μH
1	L2	0.8μH
2	C4	690pF
3	C5	132pF
4	C6	150pF
5	C0	68uF
6	R0	400Ω
7	Duty ratio of S2	50%

Figure 10, Component values of the proposed Wireless Power Transmission model

The simulation of the proposed system has been verified using SIMULINK package. With an input of 12V from the solar panel, the high step-up converter boosts this voltage to 70V which is shown in fig 11. The output of the high step-up converter is measured across the capacitor C3.

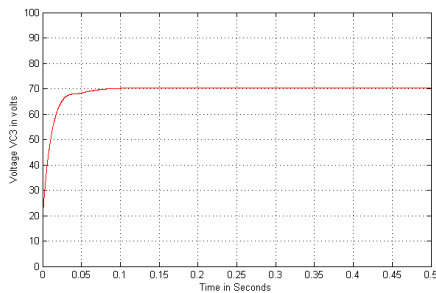

Figure 11, Output across the capacitor C3

The output voltage of the dc-dc converter stage is represented along the Y-axis in volts and time in X-axis and is measured to be 70V.

The second stage consists of a wireless power transmission setup using class E transmitter. An input of 70V is applied to the second stage and an output of 110V DC is to be obtained. The Fig 12 represents the output voltage at the secondary side of the proposed wireless power transmission model.

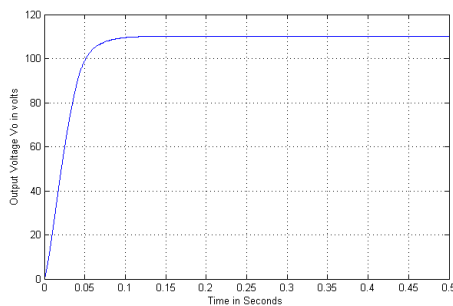

Figure 12, Output voltage of the proposed system

The fig 12 is the plot of output voltage versus time with voltage on the Y-axis in volts and time along X-axis in seconds. It is observed that the output voltage at the secondary of the wireless power transmission model is found to be 110V.

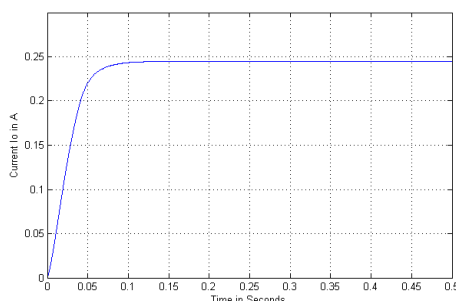

Figure 13, Output current of the proposed system

The Fig 13 represents the output current flowing through the secondary side of the proposed wireless power transmission model. The output current is represented along Y-axis in amperes and time along X-axis in seconds. It is observed that the output current flowing through the proposed wireless power transmission model is found to be 250mA.

The output power which is a product of voltage and current is found to be 27V theoretically and is found to be 27.5 from the simulation. The fig 14 shows the output power off the proposed wireless power transmission system.

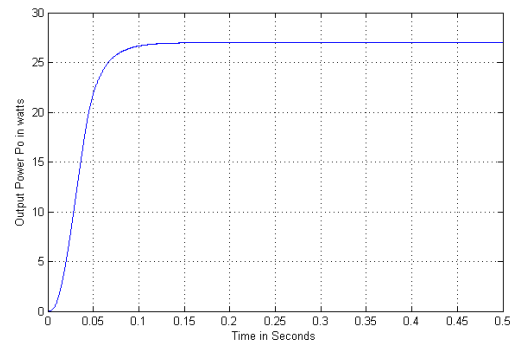

Figure 14, Output power of the proposed system

The fig 14 is a plot of output power P0 long Y-axis and time along X-axis.

CONCLUSION

This project has introduced the transmission of power wirelessly using the input from the solar panel. The proposed wireless power transmission using high step-up dc-dc converter for PV cells has been built based on the simulation performed on MATLAB/ SIMULINK. The model uses the input from the solar panel and by using a high step-up dc-dc converter, the input of 12V has been stepped up to 70V which is the given as the input to the class E transmitter. The secondary or the receiver of the proposed model receives a DC output of 110V and the power delivered to the load is nearly 28W.

REFERENCES

- [1] Qiang wang and Hong Li, "Research on the wireless power transmission system based on coupled magnetic resonances", IEEE International Conference 2011.
- [2] Q. Zhao and F. C. Lee, "High-efficiency, high step-up dc-dc converters,"IEEE Trans. Power Electron, vol. 18, no. 1, pp. 65-73, Jan. 2003.
- [3] R. J. Wai, C. Y. Lin, R. Y. Duan, and Y. R. Chang, "High-efficiency dc-dc converter with high voltage gain and reduced switch stress," IEEE Trans.Ind. Electron., vol. 54, no.1, pp. 354-364, Feb. 2007.
- [4] S. M. Chen, T. J. Liang, L. S. Yang, and J. F. Chen, "A cascaded high step-up dc-dc converter with single switch for micro source applications,"IEEE Trans. Power Electron.,vol. 26, no. 4, pp. 1146-1153, Apr. 2011.
- [5] N. O. Sokal and A. D. Sokal, "Class E-A new class of high efficiency tuned single-ended switching power amplifiers," *Solid-State Circuits, IEEE Journal of*, vol. 10, pp. 168-176, 1975.
- [6] Kuo-Ching Tseng, Chi-Chih Huang, and Wei-Yuan Shih, "A High Step-Up converter with a Voltage Multiplier Module for a Photovoltaic System". IEEE transactions on Power Electronics, vol. 28, no. 6, June 2013
- [7] Juliusz Modzelewski and Miroslaw Mikołajewski, "High-Frequency Power Amplitude Modulators with Class-E Tuned Amplifiers", Journal of Telecommunications and Information Technology April 2008.
- [8] W. Chen, R. A. Chinga, S. Yoshida, J. Lin, C. Chen1 and W. Lo, "A 25.6 W 13.56 MHz Wireless Power Transfer System with a 94% Efficiency GaN Class-E Power Amplifier", Microwave Symposium Digest (MTT), 2012 IEEE MTT-S International.
- [9] M.Karthika and Dr. C.Venkatesh, "Witricity: A Power Transmission Method for WSN", International Journal for Technological Research in Engineering, Volume 1, issue 10, june-2014.
- [10] T. Shimizu, K. Wada, and N. Nakamura, "Flyback-type single-phase utility interactive inverter with power pulsation decoupling on the dc

input for an ac photovoltaic module system," IEEE Trans. Power Electron., vol. 21, no. 5, pp. 1264–1272, Jan. 2006.

- [11] [11] C. Rodriguez and G. A. J. Amaratunga, "Long-lifetime power inverter for photovoltaic ac modules," IEEE Trans. Ind. Electron., vol. 55, no. 7, pp. 2593–2601, Jul.