

# Wireless Multichannel ECG & BCG Signal Recording Using An CDMA Network

Nisha Singh, Sr. Asst. Prof. Ravi Mishra

1(ME II Year VLSI Design, Department Of EC, SSCET, Gunwani, Bhilai Nagar (C.G), India)

2(Sr. Asst. Prof. Department Of EEE, SSCET, Gunwani, Bhilai Nagar (C.G), India)

**Abstract**— The present study is about a biometric system for a wheelchair, which can measure both bio-signal (ECG-Electrocardiogram, BCG-Ballistocardiogram) and kinetic signal (acceleration) simultaneously and send the data to a remote medical server. The equipment was developed with the object of building a system that measures the bio-signal and kinetic signal of a subject who is moving or at rest on a wheelchair and transmits the measured signals to a remote server through a CDMA (Code Division Multiple Access) network. The equipment is composed of body area network and remote medical server. The body area network was designed to obtain bio-signal and kinetic signal simultaneously and, on the occurrence of an event, to transmit data to a remote medical server through a CDMA network. The remote medical server was designed to display event data transmitted from the body area network in real time. The performance of the developed system was evaluated through two experiments. First, we measured battery life on the occurrence of events, and second, we tested whether biometric data are transmitted accurately to the remote server on the occurrence of an event. In the first experiment using the developed equipment, events were triggered 16 times and the battery worked stably for around 29 hours. In the second experiment, when an event took place, the corresponding data were transmitted accurately to the remote medical server through a CDMA network. This system is expected to be usable for the healthcare of those moving on a wheelchair and applicable to a mobile healthcare system.

## I. INTRODUCTION

There are an increasing number of people who have to use a wheelchair in their everyday life due to disability, accident or aging. Many institutions and researchers are making efforts to create environment so that those with disability can live without difficulty. As one of such efforts, this study purposed to develop a system that obtains ECG and BCG simultaneously from a subject on a wheelchair and, on the occurrence of an event, transmits the data to a remote server through a CDMA network. BCG is a non-invasive method that records body movements synchronized with the activities of the left ventricle without using electrodes [1]. It is used widely today because bio-signals such as heart rate and respiratory rate can be measured non-invasively from it. However, it requires signal processing for improving its diagnostic value [2]. Recently many institutions are studying BCG signal actively. In addition, ECG is considered the most widely known and generalized method of assessing and recording cardiac cycle and functions [3]. In general, BCG appears 0.1-0.3 behind ECG. There are also active researches to develop equipment for the wireless transmission of bio-signals such as ECG, PPG and respiratory rate using wireless communication technologies such as Zig bee and Bluetooth[4][5][6]. However, these systems need a transmitter and a receiver and have a limitation in the distance of transmission. In order to solve these problems, this study used a CDMA module. When an event has happened in the equipment developed in this study (the event button on the equipment has been pressed, the heart rate of ECG signal is under 40 or over 180, or the ECG electrode has fallen off), the equipment transmits the wheelchair patient's data to a remote server and the remote server records 48 Kbyte data (around 32 seconds) backward from the moment when the event happened. The reason for transmitting 48 Kbyte is that around 32 seconds' previous data are considered enough to show the subject's state just before the happening of the event. Thus, this study established an integrated system that can obtain ECG signal, which is the electric signal of heartbeat transmitted to the body surface, and BCG signal, which is impact energy transmitted to the body surface on each heartbeat.

## II. MATERIALS AND METHODS

### A. System structure

#### 1) Seat-type non-contact EMFi sensor mountable on a wheelchair

In this study, we made a seat-type Electromechanical film (EMFi) sensor that can measure BCG without contacting the subject and be attached to and detached from the body area network. The device is attached to the seat of the wheelchair and measures the subject's BCG. Figure 1 show the sensor used in the development and the principle of its operation.



Fig.1 Sensor used in the development and the principle of its operation

#### 2) Body Area Network

The body area network was designed to obtain bio-signal (BCG and ECG) and kinetic signal (3-axis acceleration signal) simultaneously, and on the occurrence of an event, to transmit data to a remote medical server through a CDMA network. The equipment is composed of ECG and BCG amplifier, filter, and ATmega128L micro-controller for A/D conversion, and CDMA used BSM-860s module of Bellwave. In addition, an accelerometer was used to capture the signal of wheelchair movement. In the EMFi sensor, which is made of polypropylene, if pressure is applied to the electrode film, electric charge happens in proportion to the pressure [7] [8]. The body area network is powered by 3 AA batteries.

#### 3) BCG Circuit

In this study, we made a seat-type circuit that installs a piezoelectric sensor (EMFi sensor) on the wheelchair and measures BCG without contacting the patient. For a low-power system, the BCG circuit built an instrumentation amplifier using a low-price operational amplifier (TL064, TI). Input signal goes through low-pass filter ( $f_c=24$  Hz), notch filter ( $f_c=60$  Hz), high-pass filter ( $f_c=0.3$  Hz), inverting amplifier (70 gain), low-pass filter ( $f_c=10$  Hz) and high-pass filter ( $f_c=0.06$  Hz), and then into the A/D channel of the micro-controller. Figure 2 is the block diagram the BCG circuit.

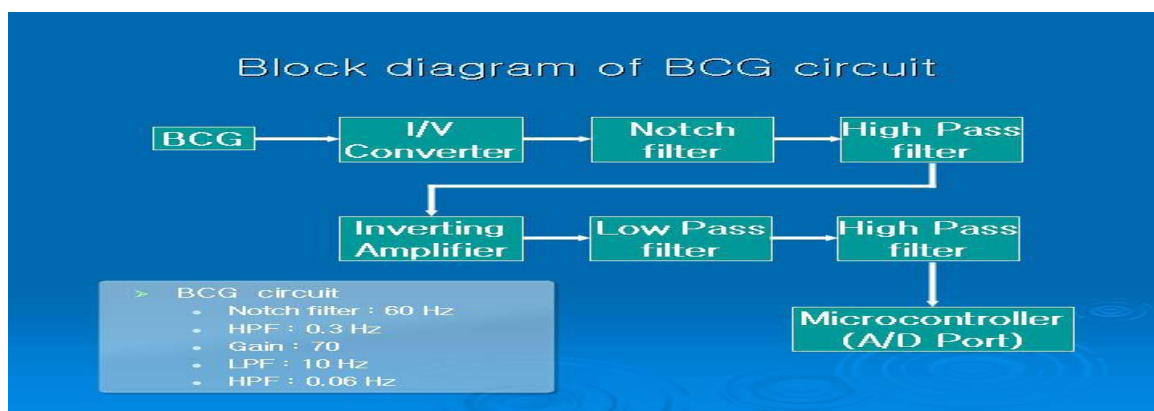

Fig.2. Block diagram of the BCG circuit

#### 4) Two-channel ECG circuit

A two-channel ECG circuit was also designed for low-power systems by building an instrumentation amplifier using a low-price operational amplifier (TL064, TI) as in the BCG circuit. We need 4 electrodes to obtain the subject's ECG signal. Three of them are used for standard induction  $V_I$  and  $V_{II}$ , and the other for noise attenuation and signal stabilization. Input signal is amplified through the two-channel ECG amplifier, and 60Hz noise is attenuated through the notch filter. The filtered signal passes through the inverting amplifier for the inversion of signal polarity, and the inverted signal passes through the low-pass filter (LPF 79.577 Hz). It again passes through the high-pass filter (HPF 0.169Hz) and enters into the A/D port of the micro-controller [9]. Figure 3 shows the block diagram of the two-channel ECG circuit



Figure 3 shows the developed equipment installed on an electrically-driven wheelchair for experiment

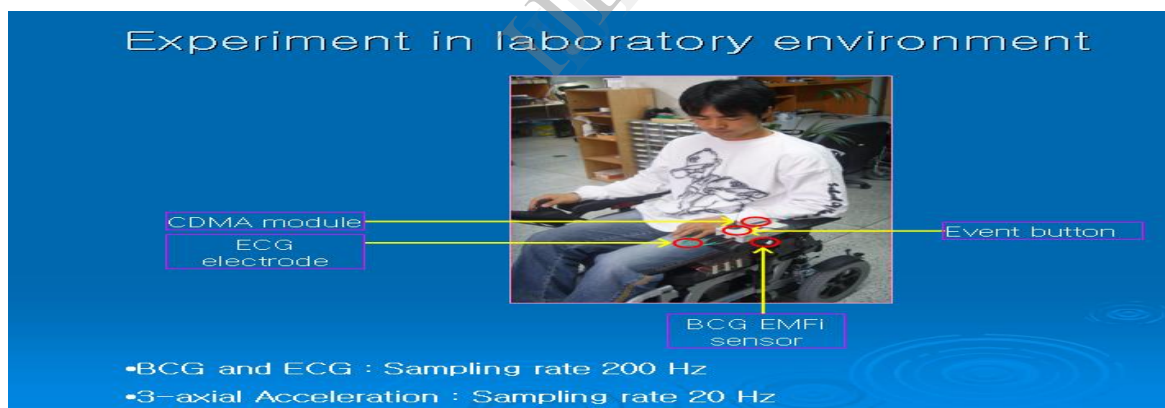

Fig.4. Wheelchair type biomedical system

Figure 5 is the block diagram of the system. ECG signal and BCG signal go through their respective amplifiers and are A/D-converted in the micro-controller. Three-axis acceleration signal is A/D-converted in MCU without amplification. The signal input to MCU is AD-converted and recorded in the SD card, and on the occurrence of an event, is transmitted to a remote server through a CDMA network. The sampling rate of ECG Lead I, II and BCG is 200 Hz, and that of 3-axis accelerometer is 20 Hz.

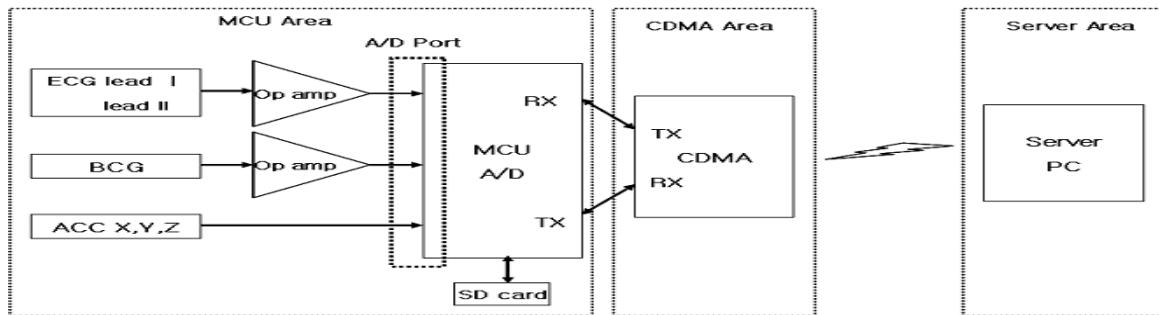

Fig.5. Block diagram of the total system

### III. RESULTS

#### A. Results of battery performance test on the occurrence of events

This study aimed to develop a system that can operate without changing batteries for over 24 hours. Thus, we tested battery performance as follows. After we connected 3 AA batteries in series, and connected them to the body area network. Then, we pressed the event button 16 times and tested whether 48 Kbyte data had been transmitted accurately to the remote server. Figure 7 shows the results. The initial voltage was 4.67V, and when the event button was pressed 16 times, the system worked normally. After around 29 hours had passed, the equipment stopped its operation.

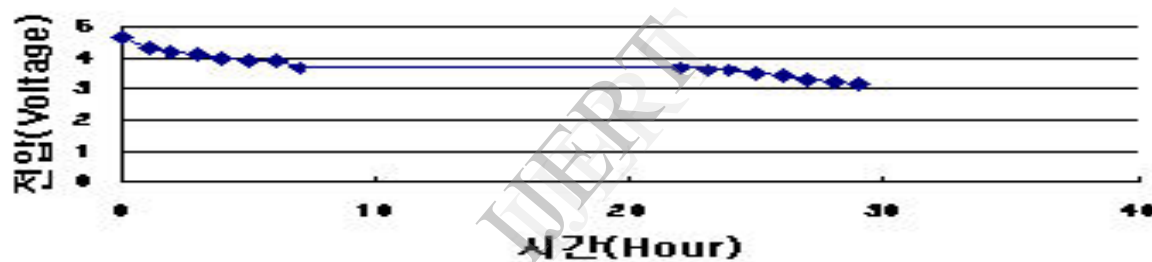

Fig.6. Results of battery performance test on the occurrence of events

#### B. Results of data transmission to a remote server on the occurrence of an event

Figure 8 shows the transmission of 48 Kbyte data recorded in the bio-signal storage medium to the server on the occurrence of an event. The top of the window displays ECG Lead I, Lead II and BCG, and the bottom displays acceleration signal X, Y and Z. In the result graph, Lead I and Lead II are ECG signal, in which the base line is stable and the amount of noise is small. In the bottom of the window, acceleration indicates changes in axis X, Y and Z while the wheelchair is moving. While the subject was driving the wheelchair, the event button was pressed and 48 Kbyte data were transmitted for around 6 seconds, and the results were recorded.

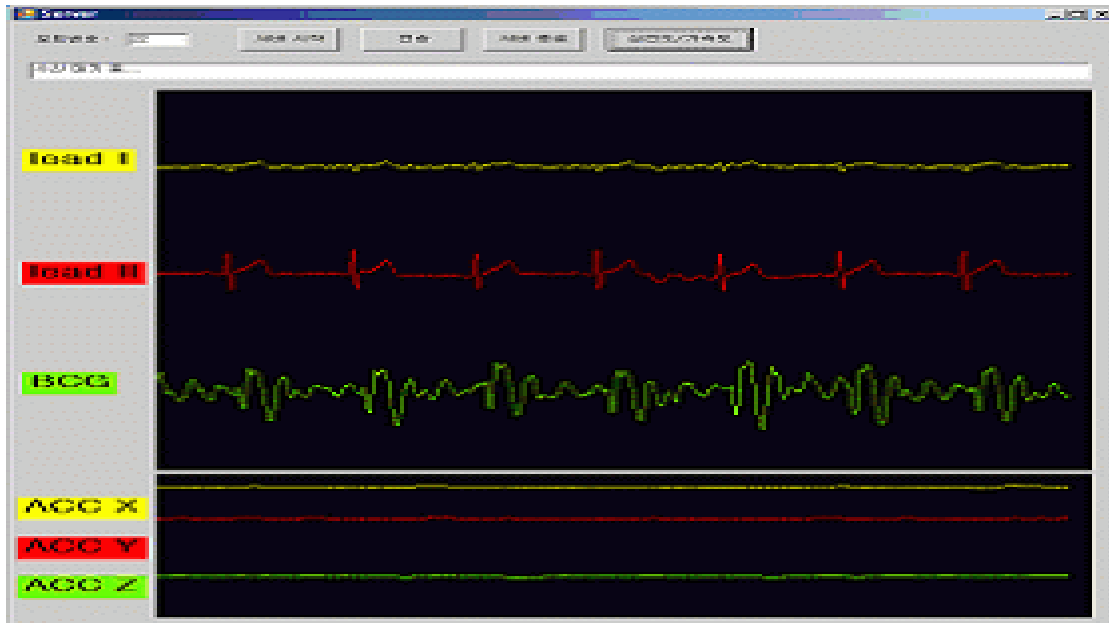

Fig.7. Results of data transmission to a remote server on the occurrence of an event results

## IV. CONCLUSIONS AND DISCUSSION

In this study, we built a system that, on the occurrence of an event, transmits 48 Kbyte data recorded in a bio-signal storage medium to a remote server through a CDMA network and display the data for monitoring the ECG and BCG of the aged, the weak, the disabled and patients on a wheelchair. In addition, we conducted an experiment that pressed the event button 16 times and confirmed that the batteries worked for 29 hours stably. This study suggests that BCG signal can be affected by the movement of the wheelchair. In addition, we need to solve the problem of noises caused by the movement of the wheelchair itself. What is more, as the developed equipment is attached to the handle of the wheelchair, we need to design a wheelchair in consideration of the shape and functionality of the device. Most of all, for the continuous and stable transmission of signal in a wireless state, if the battery is embedded in the body of the wheelchair rather than being installed as in this study, the battery problem will be solved easily and the size of the equipment can be reduced. Not limited to the simultaneous measuring of ECG and BCG, future research will be made to measure and analyze heart rate, respiratory rate and PEP (pre-ejection period), and it is expected to contribute many wheelchair users' high-quality life and welfare.

## REFERENCES

- [1] D.C. Deuchar, "Ballistocardiography", *Brit. Heart Journal*, Vol. 29, pp. 285, 1967.
- [2] Alireza Akhbardeh, SaKari Junnila, Teemu Koivistoinen, Alpo Varri, "An Intelligent Ballistocardiographic Chair using a Novel SF-ART Neural Network and Biorthogonal Wavelets", *J Med Syst.* vol 31, pp 69-77, 2007.
- [3] J.W. Clark, Jr., "The origin of biopotentials", in *Medical Instrumentation: Application and Design*, J.G. Webster, Ed., Hoboken, NJ: John Wiley & Sons, pp. 121-182, 1998.
- [4] AI Hernandez, and F Mora, G Villegas, G Passariello, G Carrault, "Real-Time ECG Transmission Via Internet for Nonclinical Applications," *IEEE Transactions on Biomedical Engineering*, 5(3), pp. 253-257, 2001.

- [5] J Andreasson, and M Ekstrom, A Fard, JG Castano, T Johnson, "Remote System for Patient Monitoring Using Bluetooth", Proceedings of IEEE, pp. 304-307, 2002.
- [6] Reza Fazel-Rezai, Mark Pauls, and David Slawinski, "A Low-Cost Biomedical Signal Transceiver based on a Bluetooth Wireless System", Proceedings of the 29th Annual International Conference of the IEEE EMBS, August pp. 23-26, 2007.
- [7] J Lekkala., M Paajanen, "EMFi-New electret Material for Sensors and Actuators", IEEE ISE, pp. 743-746, 1999.
- [8] M. Paajanen, J Lekkala and H. Valimaki Electromechanical Modeling and Properties of the Electret Film EMFI IEEE, Vol. 8(4), pp. 629-636, 2001.
- [9] J.H. Hong, J.M. Kim, T.S. Lee, "A Wireless 3 channel ECG recorder for mobile healthcare", journal of KIPS, vol 10(2). pp. 1-6, 2007.

IJERT