

# Wireless Charging and Battery Management for EV using Arduino

Savitra C T<sup>1</sup>, Hemanth Kumar E Naik<sup>2</sup>, Hoysala Bise<sup>3</sup>, Sachin K R<sup>4</sup>, Kiran J Y<sup>5</sup>

Department of Electronics and Communication Engineering,  
Jain Institute of Technology, Davangere, India

**Abstract** - Electric-powered vehicles will help reduce greenhouse gas emissions and increase fuel prices. The main purpose of wireless transmission in electric vehicles is to transfer power over a small distance. The wireless power transmission system consists of a transmitter and receiver part that is separated by a small distance. Wireless transmission technology uses a flexible electromagnetic field. This electric field is created in a free environment that carries a fixed amount of energy that creates a magnetic field around it and this field contains energy in it and the EMF is generated between the coils and transmitted to the receiver. BMS is a battery management system. In EV vehicles we use two batteries such as master and slave. The first preference is given to the master battery in BMS. If the master battery charge comes down automatically the relay will switch from master battery to slave battery.

## 1 INTRODUCTION

The proposed system uses wireless charging based on the ARDUINO microcontroller or a production method for charging electric vehicles. This program contains ARDUINO microcontroller, inductive coils, motor prototype module. Persistent weather conditions have led to the research and development of electric vehicles over the past decade. Rising global warming has created awareness among people to switch to electric vehicles. The waiting time required for charging stations while the battery is being charged will be reduced the amount of time that the discharge will be performed at the station. Although electric vehicles are an alternative, there is a need for improvements in their charging system to be the best mode of transportation. For this purpose, charging systems should be upgraded. Solid charging systems are very reliable, easy to use and timely. Also, the battery size can be reduced, and the width can be improved. This charging system can also be used in big cities. Wireless charging performance is based on Electromagnetic Induction. The cable coils in the base unit act as the main coil and create a magnetic field as the current passes through it. This field sends a stream to the nearest coil without touching it. here we look at this nearby coil as a second turn and connect it to the car, wireless charging is available. The car can charge automatically if it is mounted on a battery-connected coil. This method is used to reduce air pollution and demand in petroleum products.

### 1.1 Principle of Operation

Wireless charging technology is based on Qi standard (operated by the Wireless Power Consortium). This the standard is used worldwide for wireless charging of smartphones. The same can

be said of wireless charging electric vehicles. Wireless performance charging is based on Electromagnetic Induction.

Coils phone is a basic unit that serves as the primary and creative wrap the magnetic field where the current passes through it. This field enters the stream to the nearest coil otherwise to touch it. If we look at this nearby coil as a second wrap and connect it to a charging unit, wireless charging is available. Electric car charging systems they are in the development stage for a number of reasons such as security, cost, infrastructure etc. However, in this case paper suggests Static Wireless display Charging system as a possible example used in the future.

### 1.2 Fundamental Circuit

Figure 1 shows the block diagram of the proposed region. A transformer lowers the AC source voltage, which is then converted to DC by a rectifier circuit. An inverter is then used to convert this voltage to the needed AC voltage. The system transfer coil in the base unit receives the desired frequency voltage. The base unit will be installed on the road in the event of flexible wireless charging. The receiver will be installed beneath the vehicle. Inductive coupling is used to transfer power from the transmission coil to the receiving coil. The power is then adjusted and controlled to suit the battery requirements. Thus, battery charging will occur.

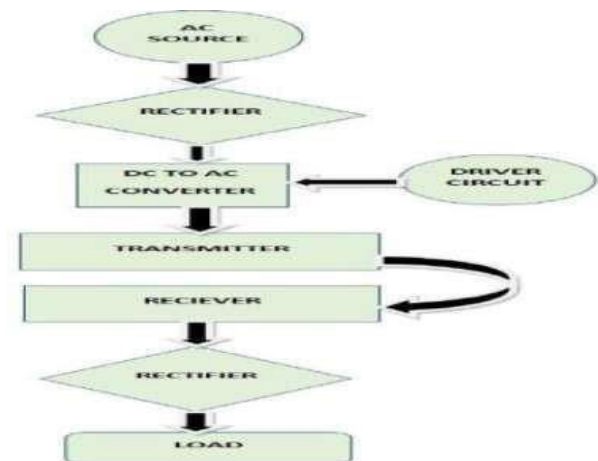

Fig 1.2: Block Diagram of working of wireless charger

## 2. IMPLEMENTATION OF WIRELESS CHARGING

Wireless charging helps to eliminate the need for holding cables and thus the possible loss of conductivity over the wire can be completely eliminated. Also, manipulating the wires during the plug charging and discharging process can sometimes be dangerous if not done properly. Thus, human intervention can be avoided for security purposes. Although wireless charging seems to be time-saving and efficient, it does come with some restrictions. A key element of implementation is the development of the infrastructure that needs to be done to achieve the goal. This will require significant investment in all phases of the project and that is why it is costly. The first wireless charging technology to be developed is standard, the system is designed to charge EVs in garages or public parking lots, where the vehicle is not operating for a long time. Because a portable connection is not required, there has been a great deal of interest in the possibility of charging EVs while on the go. Charging the EV while on the go is called flexible charging.

### 2.1 Static Wireless Electric Vehicle

WECCS Standing (Wireless Electric Car Charging System) allows drivers to simply alter the plug charger, addressing safety concerns such as travel risks and electrical shocks. Figure 2 depicts the fundamental configuration of the current WECCS.

The power you get is converted from AC to DC and then transferred to a battery bank via a power converter. Power controls and battery management systems have been installed in the wireless communication network to get any response from the main side in order to avoid any security issues. The amount of time it takes to charge is determined on the source's power, the size of the charging pad, and the distance between the two windows. Between lightweight vehicles, the typical distance is predicted to be 150-300 mm. WEVCS can be mounted vertically.

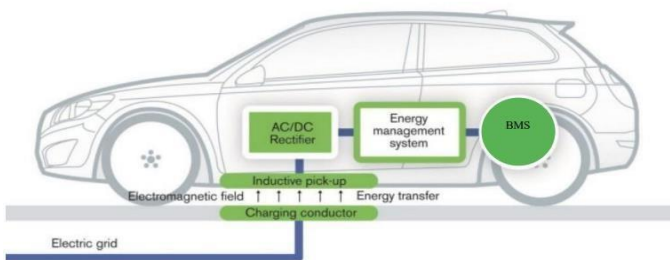

Fig 2.1 Static wireless EV charging

### 2.2 Dynamic Wireless Charging System

As the name suggests the wireless charging system Dynamic is a system in which EV is charged while on the go. Of particular concern is the transmission of electric car power and width. To improve the range of car wireless charging will be beneficial. DWCS is also called "street charging". If the charging is done at the right times a large portable battery is not needed and this makes the car easier and more economical.

## 3. BLOCK DIAGRAM

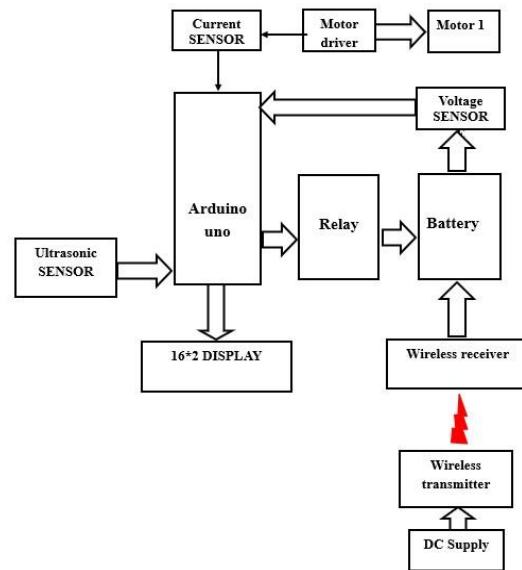

Fig 3.1 Block Diagram

## 4. FLOW CHART

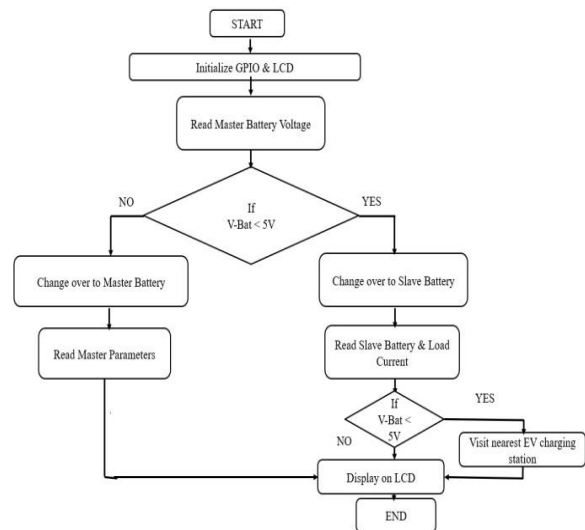

Fig 4.1 Flow Diagram

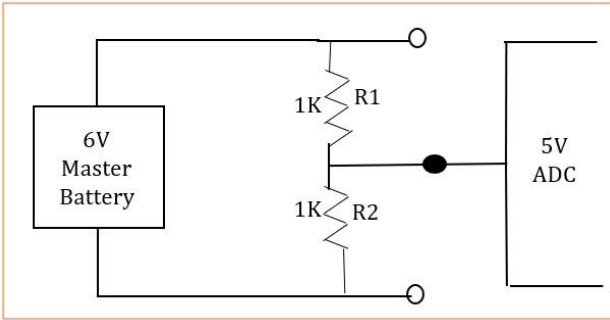
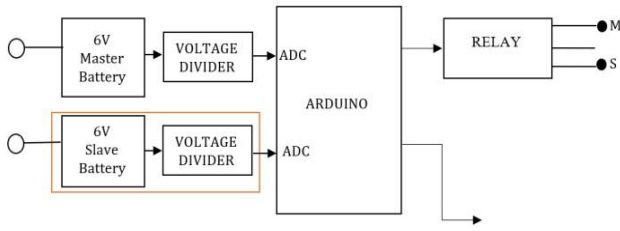
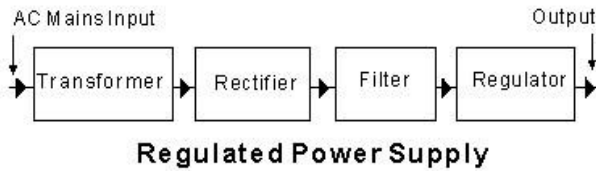

Fig 4.2 BMS of Master and Slave Battery



**Power supply Circuit**

Power supply could be a relation to a source of electric power. a tool or system that supplies electrical or other kinds of energy to an output load or group of loads is named an influence supply unit or PSU. during this project, a +5 V DC regulated power supply comes from the facility supply unit designed and implemented. The Figure shows the circuit diagram designed to urge the +5 V DC regulated power supply for the project. A rectifier could be a device that has two or more diodes arranged in order that load current flows within the same direction during each half cycle of the ac supply.

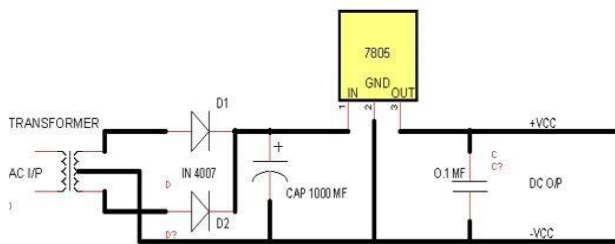

Figure 4.2.1 Power supply Circuit

Would like to rectify AC power to make full use of both half-cycles of the undulation, thus we'll need a special rectifier circuit. A rectifier is the name for such a circuit. The centre-tap arrangement, as shown in Figure above, uses a transformer with a centre-tapped coil and two diodes to provide a quiet rectifier. The following are the key components of the power supply unit:

**Step Down Transformer**

When AC is applied to the ability transformer's first winding, it can be stepped down or up depending on the amount of DC required. In our circuit, a 230v/12-0-12v transformer is used to execute the step-down operation, converting 230 V AC to 12 V AC across the coil. The transformer is positive at the top and negative at the bottom. The transformer used in the project has a 0.5 A rating. It provides isolation between the facility source and electronic circuitries by scaling down the AC voltage.

**Rectifier Unit**

One half-cycle at a time, the operation of this circuit is clearly understood. Consider the primary half-cycle, which has positive (+) on top and negative (-) on bottom source voltage polarity. Only the top diode is conducting at this time; the bottom diode is obstructing current, so the load only sees the principal 1/2 of the wave, which is positive on top and negative on bottom. During this half-cycle, only the upper 1/2 of the transformer's secondary coil transmits current, as shown in Figure.

**Rectifier With Full-Wave Center-TAP**

During the positive half-cycle of input, the top half secondary conducts, delivering the positive half-cycle to the load. The AC polarity reverses on the next half-cycle. The opposite diode, and therefore the transformer's coil's partner, now carry current, while the components of the circuit that carried current during the previous half-cycle now remain idle.

**Filtering Unit**

The rectifier unit is always followed by a filter circuit, which is commonly a capacitor acting as a surge arrester. This capacitor, also known as a bypassing capacitor or a decoupling capacitor, is used to 'short' the ripple with a frequency of 120Hz to ground as well as to leave the DC frequency to look at the output.

**Regulators of Voltage**

Voltage regulators are essential components of any power supply unit. A regulator's primary function is to assist the rectifier and filter circuit in maintaining a constant DC voltage for the device. Because of variations in the load or fluctuations in the AC liner voltage, power supplies without regulators have an inherent challenge of correcting DC voltage values. The voltage is frequently maintained within a specific tolerable area of the specified output when a regulator is attached to the DC output. The IC7805 is used to provide a +5v DC regulated supply in this project.

5. HARDWARE AND SOFTWARE REQUIREMENTS

5.4 Current Sensor

5.1 Arduino UNO



The Arduino Uno has a set of analogue and digital pins that serve as input and output points for connecting the board to external components. Inboard, there are a total of fourteen I/O pins, six of which are analogue input pins. The board contains a USB port that can be used to connect to a power supply.

5.2 LCD Display

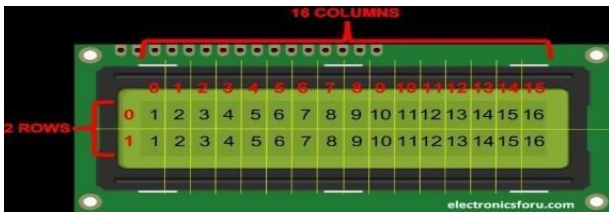

The 162 LCD gets its name from the fact that it contains 16 columns and 2 rows. There are many different combinations available, such as 81, 82, 102, 161, and so on, but the 162 LCD is the most popular. As a result, it will have a total of (162=32) 32 characters, with each character consisting of 588 Pixel Dots.

5.3 Relay Coil



Relay is an electrically operated switch. It consists of a set of input terminals for a single or multiple control signals, and a set of operating contact terminals. The switch may have any number of contacts in multiple contact forms, such as make contacts, break contacts, or combinations thereof.

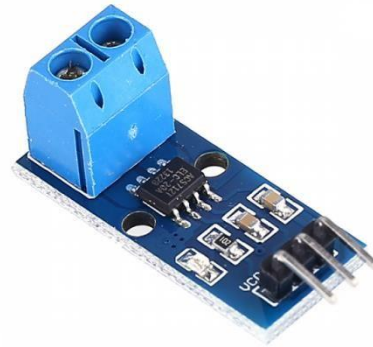

A current sensor is a device that detects and converts current to an easily measurable output voltage, which is proportional to the current through the measured path. There are a wide variety of sensors, and each sensor is suitable for a specific current range and environmental condition.

5.5 Ultrasonic SENSOR



Ultrasonic sensors work by sending out sound waves that are too high in frequency for humans to hear. They then calculate distance depending on the time it takes for the sound to be reflected back to them. This is comparable to how radar determines how long a radio signal takes to return after colliding with an item.

5.6 INDUCTION COIL



primary and secondary coil are not connected with wires, Energy transfer is due to mutual induction. Example: transformer, wireless charging pad, electric brushes on a wireless charging pad, the device are to be kept, battery will be automatically charged.

5.7 Arduino IDE

Arduino IDE (Integrated Development Environment) is programming prototype which can let the user to draft various



kind of programs and load them into the Arduino microcontroller. We can also be programmed by using other IDEs too, like Eclipse. Arduino IDE is more versatile. This Arduino IDE needs no special drivers or additional components. This is available for Windows, Linux and Mac. Cross compiler compiles for a different target platform than the one being programmed.

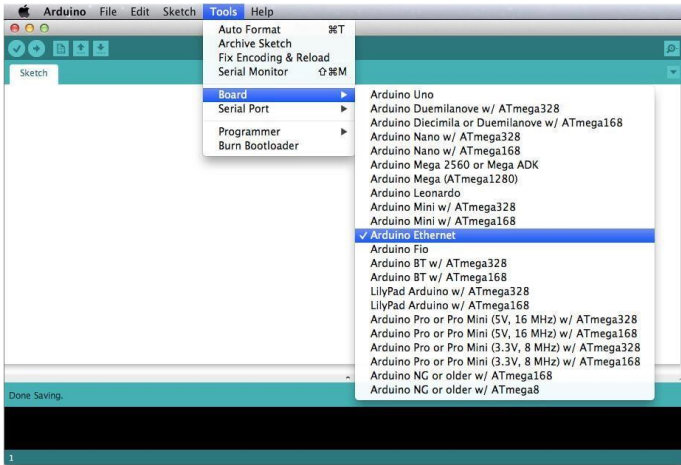

6. CIRCUIT SETUP

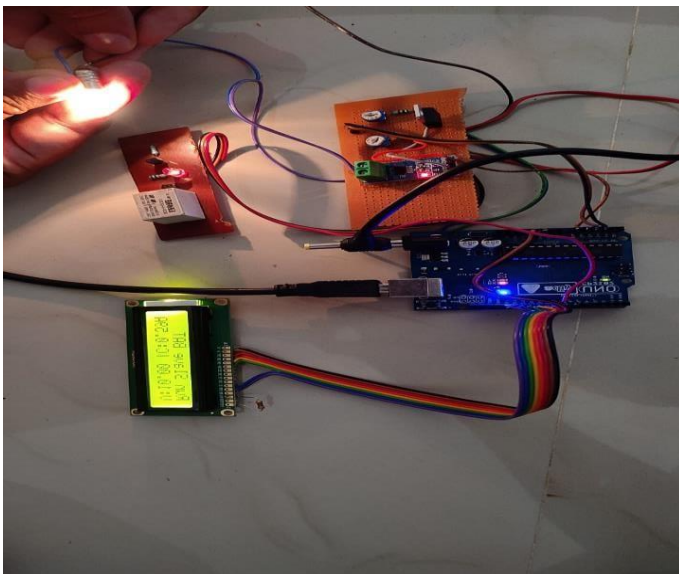

BMS SETUP

7. MERITS AND DEMERITS OF WIRELESS CHARGING SYSTEM

A) Merits:

- a) Environmentally Friendly - The most compelling reason to drive an electric vehicle is to help the environment. When compared to gasoline-powered vehicles, they do not emit poisonous emissions that pollute the air.
- b) No Costs of Fuel or Gas - Because electric automobiles do not require fuel or gas to operate, consumers may avoid the escalating costs of these items. All you have to do now is connect and you'll be ready to travel the additional 100 miles.

- c) Simple to charge - Charging an electric car is simple. You won't need to stop at a gas station to refuel your automobile before hitting the road! An electric car can be charged using any ordinary household outlet.
- d) Electric automobiles are quieter than regular cars because they have less moving parts. When they're working, they're incredibly silent. A gasoline-powered indoor car engine is significantly quieter and smoother than an electric car.

B) Demerits

- a) A scarcity of charging stations - One of the major benefits of utilising an electric vehicle is that it does not require any gasoline or diesel to run. Instead, all it takes is a charging station to connect the automobile and get it ready to go. However, one of the main roadblocks to its widespread acceptance is a scarcity of charging outlets. For example, India has a scarcity of electric vehicle charging facilities. Even if you acquire an electric vehicle, you won't be able to use it until you have access to a charging station. To increase the reception of these vehicles, a sufficient number of charging stations must first be constructed.
- b) Expensive - Purchasing an electric vehicle is still costly. There are a variety of petrol automobiles on the market, each with its own set of features and pricing. Electric vehicles, on the other hand, have fewer options, and the best are also the most expensive. Governments should strongly encourage the usage of electric vehicles by providing grants and incentives to users and manufacturers alike. Even batteries remain costly, though they are expected to drop in price in the near future.
- c) Lower power and range - When compared to electric vehicles, gasoline-powered vehicles accelerate faster. Although Tesla and Volkswagen manufacture longer-distance electric vehicles, the mid-range electric vehicle can easily travel 100 to 200 miles on a single charge. As a result, consumers are still cautious to use electric vehicles for lengthy trips or highway driving.

Low Pollution - Electric vehicles do not emit zero pollution. Even so, they contribute to some indirect pollution. Batteries and the electricity necessary to charge them are not made from renewable resources.

8. FUTURE SCOPE

Based on policy guidelines and emerging technologies. This section should visualize the future of WEVC Today, the international EV list is growing exponentially. Under the trend of industrial prosperity, the two possible approaches to WEVC include how to ensure sustainable growth of EV ownership and how to allow full play of uncontrolled EV development. In addition, the emergence of new technologies, building materials and ideas can make WEVC even more competitive. Powerful electrical appliances can benefit from advanced features as well. First, apart from flux leakage, reversing losses are another major source of energy wastage in the WEVC system.

## 9. RESULT

Wireless charging is based on the principle of electromagnetic induction. When a power cable is connected by a coil (damaged cable), it creates a magnetic field whose action generates more electricity from the second remote coil.

In this way electricity can be transferred from one device to another without physical contact. Standard import applications still require a charger and a receiver to be close. That is why these charging systems are sometimes referred to as the “nearest field.” In the electric car industry, imported charging can make it easier for cars to charge without a special socket or cable. In the standard charging mode, electricity is still supplied by the charging station or Wall box, but electrical power is sent to the car wirelessly with the charging pad where the car just needs to be parked. There is no need to drive near the car to connect your cable, or to press your badge in the charging area: charging will start automatically as soon as the output and receiver coils are facing.

Principle: instead of confined to parking lots, charging coils are located directly on the road. An electric vehicle passing over them absorbs their magnetic field and converts it into electricity, which gives the car power while being driven and slows the need to stop at a charging station.

## 10. CONCLUSION

With the development of EV technology, charging infrastructure and grid integration areas, EV popularity is expected to grow significantly over the next decade. In this context, wireless charging has sparked widespread attention as it has no spark, is locally independent and operates in a vacuum. This paper explains in detail the wireless charging technology for EVs. This paper elaborates on EVs wireless charging technology. technology offers the potential for better power efficiency, lower environmental impacts, lower life cycle costs, and greater comfort and safety operating benefits.

## REFERENCES

- [1] S. Bhattacharya and Y.K. Tan. 2012. Design of static wireless charging coils for integration into electric vehicle, Proc. IEEE ICSET, Nepal. <https://doi.org/10.1109/icset.2012.6357389>.
- [2] X. Mou and H. Sun. 2015. Wireless power transfer: survey and roadmap, Proc. IEEE 81<sup>st</sup> Vehicular Tech Conf, Glasgow UK. <https://doi.org/10.1109/vtcspring.2015.7146165>.
- [3] Supriyadi, Edi Rakhman, Suyanto, Arif Rahman and Noor Cholis Basjaruddin, “Development of a Wireless Power Transfer Circuit Based on Inductive Coupling”, “TELKOMNIKA, Vol.16, No.3,June,2018. <http://journal.uad.ac.id/index.php/TELKOMNIKA/about/conta.ct>.
- [4] Electric vehicles standards, charging infrastructure, and impact on grid integration: A technological review H.S. Das a,\*, M.M. Rahman b, S. Li, a, C.W. Tanca Department of Electrical and Computer Engineering, The University of Alabama, Tuscaloosa, 35401, USA.
- [5] Survey of the operation and system study on wireless charging electric vehicle systems Young Jae Jang Department of Industrial and Systems Engineering.
- [6] Huan Ngo, et.al., “Optimal positioning of dynamic wireless charging infrastructure in a road network for battery electric vehicles”, 2020.
- [7] Muhammad Adil, et.al., “A Reliable Sensor Network Infrastructure For Electric Vehicles to Enable Dynamic Wireless Charging Based on Machine Learning Technique”, 2020.
- [8] Altynay Smagulova, et.al., “Simulation Analysis of PI and Fuzzy Controller for Dynamic Wireless Charging of Electric Vehicle”, 2020.
- [9] Partha Sarathi Subudhi, et.al., “Wireless Power Transfer Topologies used for Static and Dynamic Charging of EV Battery: A Review”, 2020.
- [10] Aqueel Ahmad, et.al., “A Comprehensive Review of Wireless Charging Technologies for Electric Vehicles”, 2017.