

# WIRELESS AMR SYSTEM USING ZIGBEE TECHNOLOGY

*Sarang D. Patil.*<sup>1</sup>

*ME(E.C.)JNEC Aurangabad.*<sup>1</sup>

*Prof. S.N. Pawar.*<sup>2</sup>

*Associate Prof. JNEC Aurangabad.*<sup>2</sup>

**Abstract** A networked wireless AMR (automatic meter reading) system based on wireless sensor networks and ZigBee technology is presented in this paper for solving the problems existed in the existing meter reading system. An AMR system based on CC2420 is designed. The hardware structure of system employs distributed structure based on wireless sensor networks, which consist of measure meters, sensor node, data collectors, server and wireless communication network. The tree network topology was adapted in designing system. For a short distance transmission, the data collectors collect data from the meter sensors using the ZigBee communication. For a long distance transmission, from the data collector to the server, system uses TCP/IP protocols. The ZigBee technology enhances the flexibility and the practicality of AMR system.

**Key Words:** Automatic meter reading system, ZigBee technology, Remote Measurement.

## 1. INTRODUCTION

Automatic meter reading (Automatic Meter Reading) system is used to telemeter the consumption of electricity, gas, water, liquid, oil and steam, since the direct physical access or visual reading of meters are very inconvenient. There are many problems in existing AMR system.[1]

The AMR system can be divided into two kinds according to communication medium; they are wired AMR system and wireless AMR system. The cost and difficulty of wiring are increased when adopting wired AMR system, meanwhile the agility is failed so the wired AMR system is limited to an extend and apply. The wireless AMR system has congenial superiority relative to the wired AMR system because it adopts advanced wireless communication technology.[2]

Wired AMR system adopts RS485 bus and electric power carrier wave. The system based on RS 485 is simple and easy to install. But it has limited no of nodes. Hence it is not suitable for large scale AMR system. The stability and

reliability of power carrier wave base AMR system very low [2].

The wireless system based on GSM/GPRS is popular. But the fee of using GSM/GPRS network is needed, and the cost of hardware system is very high. In this paper we present a remote AMR system based on wireless sensor network. In this system Zigbee technology which works in international free frequency segment and processes self organization function is adapted to solve the problem in existing meter reading system. The structure of system employs the distributed structure which consists of measure meters, sensor nodes, data collectors, server and wireless communication networks. For a short distance transmission, the data collectors collect data from the meter sensors using Zigbee communication. For long distance transmission from the data collectors to server system uses TCP/IP protocol. The collector is designed in software. The data collector is used for protocol conversion from Zigbee protocol to TCP/IP protocol before transmission.

The system proposed in this paper has many significant excellences, such as networked wireless

low power consumption. The use of embedded system improves the stability of the system. By using this system the meter reading task can be done at table of energy supply companies hence it reduces manual errors occurred while taking manual reading. This system can also be used to measure and manage water supply gas supply and heat supply simply by changing the meters used.

## 2. ZIGBEE TECHNOLOGY OVERVIEW

Zigbee is an IEEE 802.15.4 standard for data communications with business and consumer devices [3]. It is designed around low-power consumption allowing batteries to essentially last forever. The Zigbee standard provides network, security, and application support services operating on top of the IEEE 802.15.4 Medium Access Control (MAC) and Physical Layer (PHY) wireless standard [4]. It employs a suite of technologies to enable scalable, self-organizing, self-healing networks that can manage various data traffic patterns [5]. Zigbee is a low-cost, low-power, wireless mesh networking standard. The low cost allows the technology to be widely deployed in wireless control and monitoring applications, the low power-usage allows longer life with smaller batteries, and the mesh networking provides high reliability and larger range. Zigbee has been developed to meet the growing demand for capable wireless networking between numerous low power devices [5].

The Zigbee alliance is working closely with the IEEE to ensure an integrated, complete, and interoperable network for the market. The Zigbee Alliance will also serve as the official test and certification group for Zigbee devices [4]. Zigbee is the only standards based technology that addresses the needs of most remote monitoring and control and sensory network applications. The 802.15.4 specification [3] only covers the lower networking layers (MAC and PHY). To achieve interoperability over a wide range of applications such as Home, Industrial or Building Automation, the higher layers must be standardized as well.

The Zigbee Alliance has produced such a standard, using 802.15.4 wireless (generally in the 2.4 GHz band) as the low-level transport [4].

Zigbee is designed as a low-cost, low-power, low-data rate wireless mesh technology. The Zigbee specification identifies three kinds of

devices that incorporate Zigbee radios, with all three found in a typical Zigbee network.

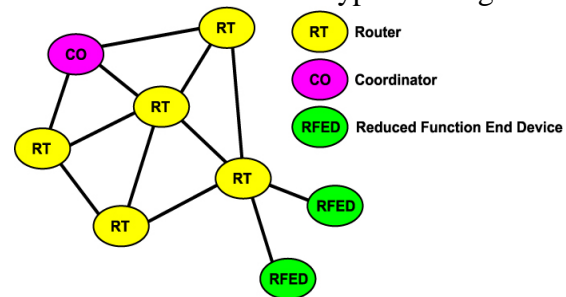

Fig1: Zigbee networks incorporate coordinators, routers, and reduced function end devices

**Zigbee coordinator (ZC)** The most capable device, the coordinator forms the root of the network tree and might bridge to other networks. There is exactly one Zigbee coordinator in each network. It is able to store information about the network, including acting as the repository for security keys.

**Zigbee Router (ZR)** Routers can act as an intermediate router, passing data from other devices.

**Zigbee End Device (ZED)** Contains just enough functionality to talk to its parent node (either the coordinator or a router); it cannot relay data from other devices. It requires the least amount of memory, and therefore can be less expensive to manufacture than a ZR or ZC.

The Zigbee Alliance specifies the logical network, security, and application software, which are implemented in a firmware stack. It is the Zigbee networking stack that creates the mesh networking capability. Each microcontroller/RF chip combination requires its own Zigbee stack due to the differences in microcontrollers and RF chips. Typically, the Zigbee stack is included with either the microcontroller or RF chip. The stack may belong to the chip vendor, be provided by the chip vendor from a third party source, or be provided by a third party source for a specific microcontroller/RF chip combination.

The application layer is defined by profiles, of which there are two types: *public profiles* are those certified by the Zigbee Alliance for interoperability purposes, and *private profiles* are for use in closed systems.

The adaptation ISO-OSI network reference model for ZigBee purposes is illustrated in the Fig.2 . ZigBee network model does not use presentation, session or transport layer and user application is directly tied into Application layer

(APL). This figure shows also IEEE, ZigBee Alliance, and ZigBee product end manufacturer particular responsibility for ZigBee certified product as well as hardware and software proportion in ZigBee.

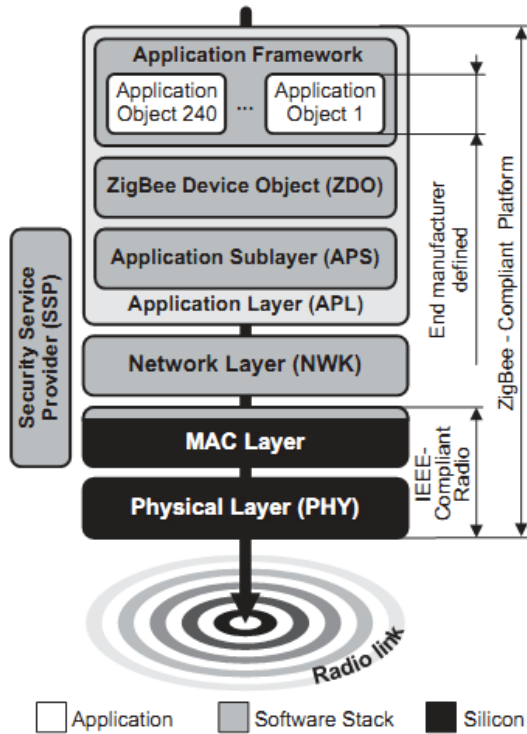

Fig2: adaptation of OSI/ ISO model to Zigbee standard

### 3. SYSTEM WORKING

The digital meter directly measures the consumption of electricity. The digital meter gives output in the form of pulses. It generates a low to high pulse on every consumed unit. This high to low pulse is given to microcontroller. The microcontroller counts these pulses and increment internal counter. This counter value will be sent through Zigbee transmitter to Zigbee coordinator.

Digital meter, microcontroller, and Zigbee transmitter collectively form end device as shown in fig. which is fitted at home of end user.

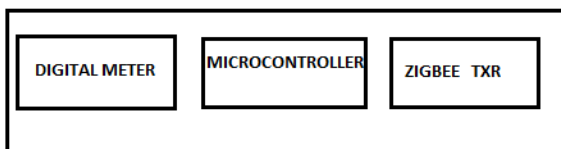

Fig3: End device (wireless sensor node)

The wireless sensor nodes used are based on the Zigbee compliance product from

Cirronet [6]. The high power transmission type ZMN2405HP Zigbee module is using the CC2430 transceiver IC from Texas Instrument comply to the IEEE 802.15.4 standards with a maximum transmission power of 100 mW using the dipole antenna and 250 mW using the directional patch antenna. The transceiver IC is integrated with the PIC 16F74 microcontroller. The module alone requires a 5VDC power supply, multiple sensor inputs/outputs with ADC, operating at a frequency of 2.4 GHz with a configurable sleep mode to get the best of power consumption as low as 3uA. The main microcontroller in the module is reprogrammable whether to function as an end device as in Fig4, router or central node.

The Zigbee transmitter sends the data received from digital meter to central node by using Zigbee transmission Protocol. Each group of wireless sensor nodes has one central node. This central node is connected to substation via TCP/IP protocol.

The central node collect data from all transmitting ends (readings of all meters) convert this data into TCP/IP packets. For this purpose it will require Zigbee to TCP/IP converter.

Data received from the end device nodes is sent to the computer using the RS 232 protocol and data received is displayed using the built GUI. The user friendly GUI is The central node consists of a same Zigbee module programmed as a coordinator that receives the data sent from the sensor nodes (end device) wirelessly. The coordinator is battery powered. It is programmed using the Visual Basic 6.0 and is able to receive packet information in real time and convert these packets into TCP/IP packets.

Two Zigbee modules are connected to single node using star topology. As shown in fig. Also this node is connected to central server by using TCP/IP protocol.

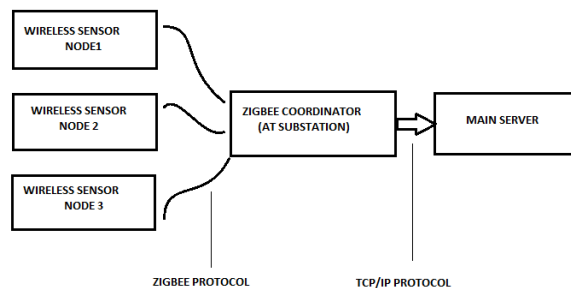

Fig4: conceptual block diagram of system

At the end of month if some user don't pay bill then using this system the power supply can be cut from substation level. For this purpose relay is fitted in each wireless sensor node and it can be activated from substation using 'meter off' command in software designed for the system.

#### 4. SOFTWARE DESIGN

There are two GUI designed for this system 1<sup>st</sup> GUI is for central node and 2<sup>nd</sup> one is for main server. The GUI platform was developed using Visual Basic 6.0 programming. The 1<sup>st</sup> GUI is able to interact with the hardware (central node). The software also takes care of conversion of Zigbee packets into TCP/IP packets. The 2<sup>nd</sup> GUI and software separates each meter reading into individual account. 1<sup>st</sup> GUI displays meter readings of each user and commands of meter ON and meter OFF. The GUI of central node and main server are as shown in fig.5&6

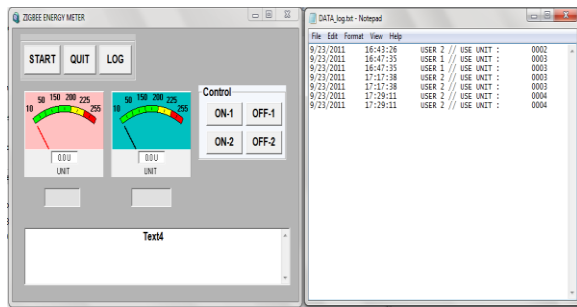

Fig5: GUI for controlling Central node

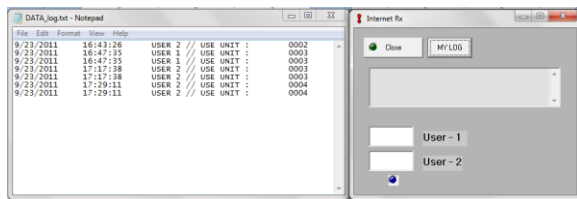

Fig6: GUI for main server

#### 5. MEASUREMENT

Several measurements were carried out to evaluate performance of Zigbee based AMR system to confirm the reliability and feasibility of using it for the actual monitoring purpose.

##### A. Power Consumption

Low power consumption is an important criterion in the WSN deployment to make sure it is able to operate in long time with minimum maintenance. The power consumption

measurement is only carried for the central node as the end devices are practically mains powered.

During the measurement, the central node is configured to be in a timer sleep mode condition. The node is configured to wake up at every 30 minutes interval for 100ms just to receive the data from end devices. For the rest of the time, the central node is in a sleep condition.

##### B. Coverage Performance

Coverage is another important aspect of WSN as it shows how large area of monitoring can be covered and to guarantee the delivery of data from the sensor nodes to the base station at reliable signal strength.

Measurement is carried out in a flat outdoor open field with no obstacles assumed close to actual application. Central node is located at the center of the area and end devices are placed at certain interval of distance at different angle covering 0° to 360°. The average signal strength is based on the value of the LQI received at the central node for 20 cycles. All the end devices and central node at the substation is using a 2 dB gain Omni directional dipole antenna with transmitted power of 100 mW.

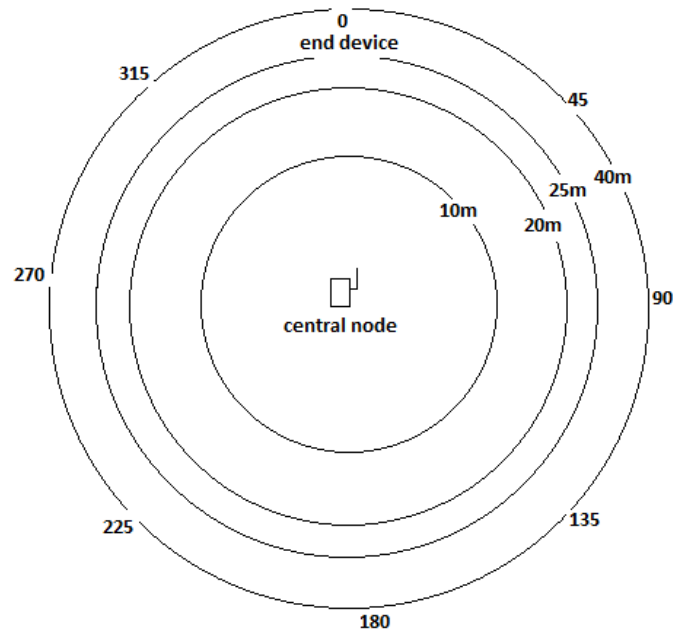

Fig7: coverage measurement method

#### 6. RESULT

Following table shows the average power consumption for central node for both during sleep mode and active mode condition.

**Table1: central node power consumption**

State	Voltage(V)	Current(mA)
Active	9.0	35.5
Sleep	9.0	28.8

**central node for a distance of 0 to 50 m**

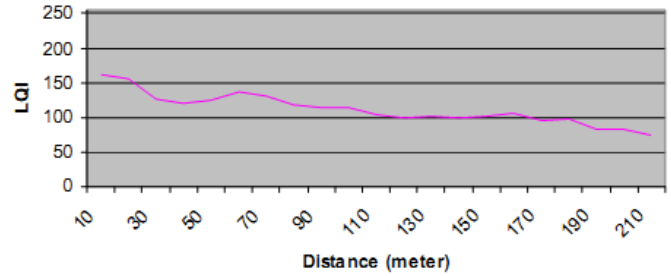

**Fig: Value of LQI for extended distance up to 210 meters**

It is important to be mentioned here that the above measured average power consumption is not considering the power consumed by the module only, but also includes the voltage regulation component and its peripheral circuits consists of basic components such as resistor and capacitor.

Power consumption during active mode:  
 = 35.5 mA x 100ms / (60 x 60 x 1000)  
 = 0.00099 mAH

Power consumption during sleep mode :  
 = 28.8 mA x 30 minutes/60  
 = 14.4 mAH

Total power consumption = 14.4 + 0.00099  
 ≈ 14.4 mAH

**B. Coverage Performance**

The following Fig. 8 shows the coverage performance based on the LQI value. Between 10 to 50m distance from the base station, an average uniform signal strength is obtained comply with the use of Omni directional antenna. In order to further evaluate the maximum distance that can be reached, one direction is chosen and the distance of end device from the base station is extended. As shown in Fig.9, reliable signal strength can still be obtained at 100% success of packet delivery up to the distance of 210 m. The decrease of the LQI value with the distance extension is expected. Unfortunately the maximum reachable distance cannot be determined as the distance cannot be further extended due to the geographical constraint.

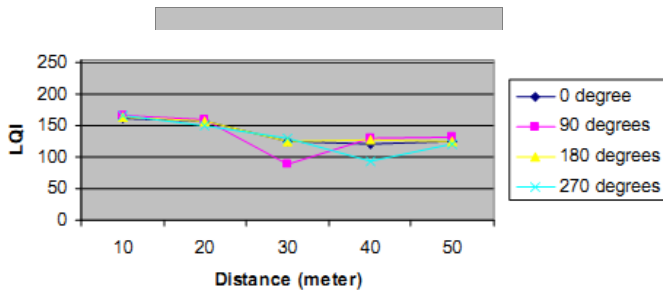

**Fig8: values of LQI based on distance and direction from**

**7. CONCLUSION**

The AMR system is extremely useful in urban areas as it reduces manual errors. As mentioned in this paper the prototype hardware and monitoring software were developed successfully.

Based on the result the central node can be operated for minimum 12 hours by using 9V 15mAH battery.

In particular digital meters end device shows best performance during experiments. For short distance transmission zigbee device don't have any problem. But for long distance transmission we have to rely on TCP/IP.

The end user can monitor the consumption of electricity. The meter reading task can be finished at the management department of residence by using this system. The electricity company can direct charge the amount through customer's bank if this system is connected to banking system.

The presented paper covers many advance topics of computer science and wireless networks. Furthermore experiments should carry out on this system to make it practically usable. Certain issues such as power consumption of central node should be should be studied and improved.

On the coverage performance, higher range sensor node can be used. And use of router will also improve the coverage performance. All central nodes can be connected in mesh topology to reduce the no. of required central node and router.

Overall, the proposed implementation of high power Zigbee based AMR system offer a low power consumption with high reliability based on the preliminary result is presented. Another important fact of this system is the easy installation of the system where the central node can be place at the local residence of management bodies and management task can be done by any person with minimal training at the beginning of installation of the system.

## 8. REFERENCES

- [1]. J. Douglas. "The future of metering" EPRI journal 19-23, march/April 2008
- [2]. Liting Cao, Wei Jiang "Networked wireless AMR system using zigbee technology" 2008 Chinese Control and Decision Conference (CCDC 2008)
- [3]. IEEE: IEEE Std 802.15.4™-2003, [online]. Available: <http://standards.ieee.org>
- [4]. The Zigbee Alliance website. [Online]. Available: <http://www.zigbee.org/>
- [5]ZigBee Alliance, ZigBee Specification December 1, 2006, [online]. available: [www.zigbee.org](http://www.zigbee.org)
- [6]Cirronet, *ZMN2405/HP Zigbee™ Module Developer's Kit User Manual*, Rev A 2007.
- [7]D.Culler, D.Estrin and M.Srivastava, "Overview of sensor networks," *IEEE Computers*. 37(8):41-49, August 2004.
- [8]Zulhani Rasin Hizzi Hamzah," Application and Evaluation of High Power Zigbee Based Wireless Sensor Network in Water Irrigation Control Monitoring System" 2009 IEEE Symposium on Industrial Electronics and Applications (ISIEA 2009), October 4-6, 2009
- [9]Jon Adams "Designing with 802.15.4 and Zigbee" [www.zigbee.org](http://www.zigbee.org)