

Wired and Wireless Transmission of Data between Pen drives and Pen drive to Computer Using ARM

Narendran.S¹

¹Electronics and Communication Engineering
SNS College of Engineering
Coimbatore, Tamil Nadu
naren.sn.69@gmail.com

Rajeshkumar.P²

¹Electronics and Communication Engineering
SNS College of Engineering
Coimbatore, Tamil Nadu
snsrajeshkumar@gmail.com

Abstract— In our project we are transferring the data between two pen drives without using any computers or laptops. With the help of this project we can not only transfer the data but also we can see the transfer of the particular file which we want to send by using touch screen display. We have designed a project which is known as pen drive to pen drive data transfer, and pen drives to mobile in which we will be transferring the data between two pen drives and pen drives to mobile using ARM processor and also we use Bluetooth for wireless transmission of data.

Keywords—ARM7, Touch Screen, VNC1L IC, Zigbee, USB Port.

I. INTRODUCTION

Already thriving within the telecommunications market, wireless technology is preparing to embrace computing on an even larger scale. Presently, most people encounter wireless local area networks (WLANs) in airport lounges and tech-savvy offices. Everywhere around the world, this new generation prefers the wireless technology for their work and also the technologies are growing by leaps and bound to carry out all the desires of the customers to fulfill their demands. Several data and application are developed daily which common computer user has to transfer from one USB Flash device into another, with the minimum wastage of time. For this user has to first find a computer then wait for it to boot up, then plug in his device, and then transfer the data. Different types of USB flash devices are used now-a-days. It is not necessary that all of these devices are supported by the computer and the operating system and their device drivers are available and installed. Carrying a computer or a laptop just for the sake of data transfer is not affordable these days in the age when people want all devices to be handy. Moreover, transferring data via a computer involves a lot of power to be wasted, since the computer has to be entirely functional before it can transfer data. Also, the threat of viruses and malware has made the life of computer users more complicated. These viruses get activated as soon as the device is plugged into the system and get copied along with other data from one flash device into another. Our project here can provide a valuable solution to all problems faced by person in above situations. Our aim is to build a small and handy device to transfer data from one USB Flash device to another or to mobile phones.

II. IMPLEMENTATION DETAILS

1.0 System block diagram

The study of the block diagram is very helpful to the designer.

A. GENERAL OPERATION

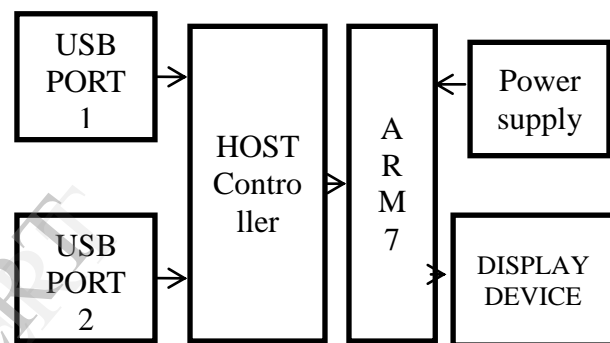

Fig 1.0 general block diagram

In the block diagram we can observe, whenever we insert the pen drive into the USB port then an signal will be sent to the arm processor indicating that source pen drive is inserted so now arm processor will start fetching the data from the source pen drive into the buffer and arm processor waits for the signal from destination pen drive. When arm processor gets the signal from the destination pen drive now arm processor is ready to transfer the data between those. Only the arm processor should get the input from external hard key from the user, once the user press the hard key the arm processor gets the information to transfer the data between two pen drives. While transferring the data the led blinking rate will be increased when data transfer is completed then led will stop blinking.

B. ARM (LPC 2138)

It is the heart of the system. It is important unit of the system because it reads data which we programmed and stored into its ROM, Then it executes it and controls the Display as well as Vinculum VNC1L Embedded USB Host controller. When key is press it read the data from source pen drive and writes to destination pen drive. LCD Display: Frequently, a C program must interact with the outside world using input and output devices that communicate directly with a human being. One of the most common devices attached to an ARM7 is an LCD display. Some of the most common LCDs connected to the ARM7 are 16x2 and 20x4 displays. This means 16 characters

per line by 2 lines and 20 characters per line by 4 lines, respectively. It displays events taken into microcontroller step by step alphanumerically. So it is convenient us to know what is currently running in the system. It displays the start and finish of the data transfer.

III. USB HOST CONTROLLER IC - VNC1L

To begin with, selection of the USB host controller IC is to be done. Host controllers can be found in market, in two types viz. Dedicated IC for USB Host, Slave and device operations, and USB Host controllers included in microcontrollers. The second most important criteria to look for is the presence of two USB ports on the Host Controller to avoid the use of buffer and extra hardware. One more feature to look for was support for FAT-32 file system included hardwired on the Host controller to avoid complications in microcontroller code to decode it. A dedicated USB Host Controller from Vinculum was found- VNC1L. It has got following features over host controllers included on chip of General Purpose Microcontrollers:

A. THE DEVICE WILL HAVE FOLLOWING FEATURES

- Flash Drive USB 2.0 with Bluetooth chip
- Powered by 9V battery
- Hardware to install Bluetooth drivers
- Turn on/off switch for Bluetooth
- Plug and Go Function

B. SOME OF ITS BENEFITS FOR USERS INCLUDE

- Single Interface for many devices.
- Considerably high Data rate.
- Automatic Configuration.
- Easy connection.
- Hot Pluggable.
- No user Settings.
- Frees Hardware Resources for other devices.
- No extra Power Supply needed.
- Low Cost and Low Power consumption.

3. Open source support available online.
4. Versatility.

System Flow Chart:

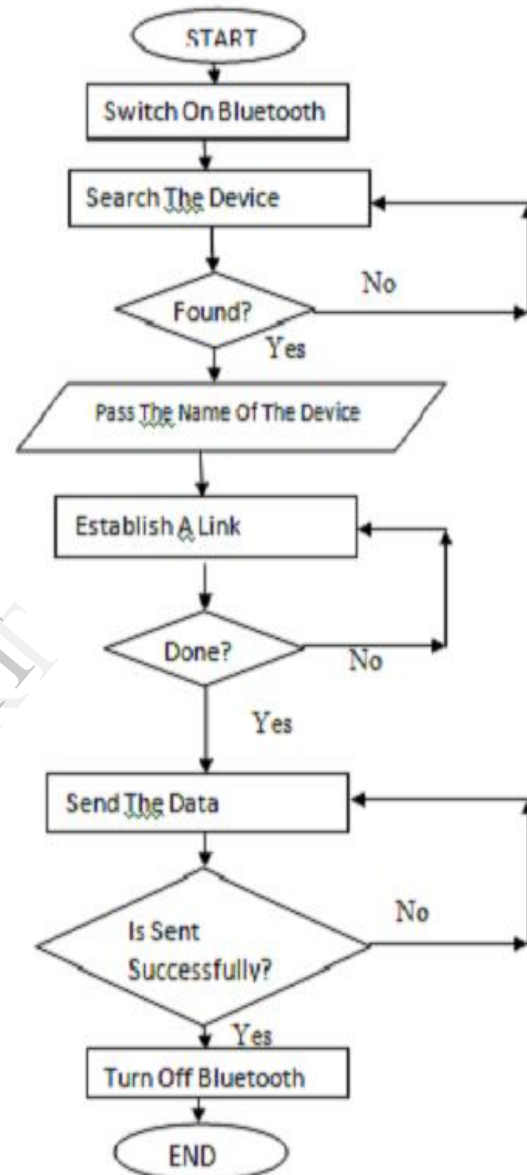

IV. GENERAL IDEA OF THE PROJECT

The idea includes a flash drive of 1GB capable of transmitting and receiving data wirelessly between itself and other devices.

Infrared, Bluetooth and satellite communication can be used for this objective. But due to very less range of operation of infrared and expensive satellite communication, we have decided to use Bluetooth for this wireless data transmission. Bluetooth, named after a king of Denmark, Herald Bluetooth, works on ISM Band of 2.4GHz to 2.48GHz.

C. BENEFITS FOR DEVELOPER INCLUDE

1. Operating system support.
2. Peripheral support.

ACKNOWLEDGMENT

Transferring the data through USB in today's scenario is the most common task. But the problem is that for transferring the data to a personal computer or laptop is difficult if u don't have any of them. It is affordable to purchase a USB data drive than purchasing a laptop or PC. Therefore we came up with a handled battery operated affordable device which can transfer the data between two USB data drives without the help of PC or laptop.

The advantage of this device is that it is battery operated so there is no need of power supply connection and data transfer can take place at any place. Currently we have design the

system for transfer of data up to 2GB only, but it can be increased by proper selection of the bus.

Here in this we used and touch screen display for selecting the particular which has to be transferred and also we implemented Bluetooth for wireless transmission.

FUTURE WORK

- At present only 1mb of data is being transferred by interfacing additional memory to ARM we can transmit large amount of data
- Here only text and image is transferred in future video and audio can be added
- Wi-Fi can be used for wireless transmission instead of zigbee

REFERENCES

- [1] FTDI Inc, www.ftdichip.com/document Reference No.: FT-000006v. Vinculum Firmware User Manual Version 2.05.
- [2] Parmar, C.D.; Dwivedi, V.V.; Wandra, H. H., "Firmware for file transfer between Bluetooth module and flash memory through microcontroller in an emerging concept of wireless portable memory access," Communication Control and Computing Technologies (ICCCCT), 2010 IEEE International Conference on , vol., no., pp.42,46, 7-9 Oct.2010doi: 10.1109/ICCCCT.2010.5670781
- [3] International Journal of Engineering Research and Development, ISSN: 2278-067X, Volume 1, Issue 6 (June 2012), PP.25-34.
- [4] Arfwedson, Henrik and Sneddon, Rob, "Ericsson's Bluetooth Modules", Nov 4,1999. Ericsson Review No.4, PP 198-205
- [5] IOSR Journal of Electronics and Communication Engineering (IOSR-JECE) ISSN: 22
- [6] http://www.freebsd.org/doc/en_US.ISO88591/books/handbook/network.bluetooth.html
- [7] <http://www.gsmarena.com/glossary.php3?term=bluetooth>
- [8] <http://www.indiastudychannel.com/experts/21785-internal-structure-pen-drive.aspx>
- [9] http://en.wikipedia.org/wiki/USB_flash_drive