

Tuning of PID Controller for Ball and Beam System

Rasika Datar

PG Student of Electronics Dept., RTMNU,
JD College of Engineering and Management,
Nagpur, Maharashtra, India

Prof. Sunil Gupta

Associate Professor, Electronics Dept, RTMNU,
JD College of Engineering and Management,
Nagpur, Maharashtra, India

Prof. Rahul Langde

Assistant Professor, Electronics Dept, RTMNU,
JD College of Engineering and Management,
Nagpur, Maharashtra, India

Abstract:- Proportional Integral Derivative controllers are widely used controllers. It is known for its reliable operation, optimal performance and has simple structure. The aim is to design a PID controller for Ball and Beam system to track the ball to a commanded position by varying the beam angle. The present work deals with the PID controller implementation of highly nonlinear ball and beam system. The mathematical model is developed for this system and it is implemented and simulated using MATLAB software. The control algorithm used in the present study was found to be effective in controlling the non-linear unstable system.

Keywords: MATLAB, PID controller

1. INTRODUCTION

The ball and beam system is one of the most enduringly popular and important laboratory models for teaching control systems engineering. The ball and beam system is widely used because it is very simple to understand as a system, and yet the control techniques that can be studied it cover many important classical and modern design methods. It has a very important property - it is open loop unstable. The system is very simple - a steel ball rolling on the top of a long beam. The beam is mounted on the output shaft of an electric motor and so the beam can be tilted about its center axis by applying an electrical control signal to the motor amplifier. The position of the ball on the beam can be measured using a special sensor. The control job is to automatically regulate the position of the ball on the beam by changing the angle of the beam. This is a difficult control task because the ball does not stay in one place on the beam but moves with an acceleration that is proportional to the tilt of the beam. In control technology, the system is open loop unstable because the system output (the ball position) increases without limit for a fixed input (beam angle). Feedback control must be used to keep the ball in a desired position on the beam.

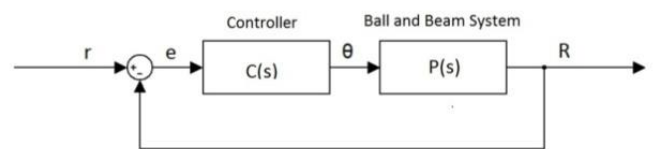

Figure 1:-Block Diagram of Ball and Beam System

In this paper, a theoretical analysis of the ball and beam system is conducted by employing physical laws and linear approximation. A performance comparison among the different control techniques is presented in both simulation and experimental conditions. A system identification (ID) process is essential in control design processes.

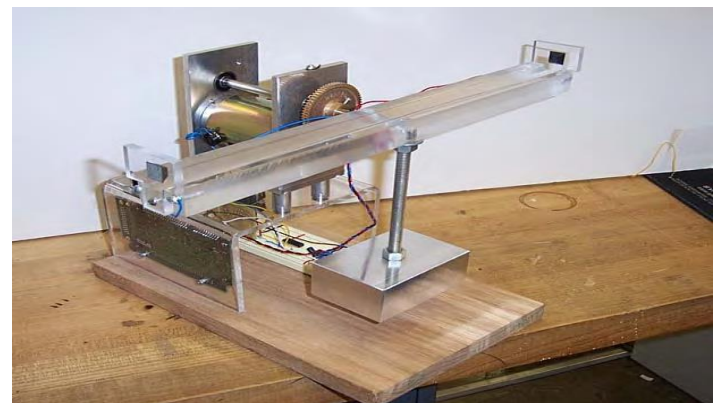

Figure .2:- Ball and Beam system model

2. METHODS AND MATERIALS

2.1 PID controller theory

The PID control scheme is named after its three correcting terms, whose sum constitutes the manipulated variable (MV).

$$MV(t) = Pout + Iout + Dout$$

where Pout, Iout, and Dout are the contributions to the output from the PID controller from each of the three terms, as defined below.

2.2 Proportional term

The proportional term (sometimes called gain) makes a change to the output that is proportional to the current error value. The proportional response can be adjusted by multiplying the error by a constant Kp, called the proportional gain. The proportional term is given by:

$$P_{out} = K_p e(t)$$

A high proportional gain results in a large change in the output for a given change in the error. If the proportional gain is too high, the system can become unstable. In contrast, a small gain results in a small output response to a large input error, and a less responsive controller. If the proportional gain is too low, the control action may be too small when responding to system disturbances. In the absence of disturbances, pure proportional control will not settle at its target value, but will retain a steady state error that is a function of the proportional gain and the process gain. Despite the steady-state offset, both tuning theory and industrial practice indicate that it is the proportional term that should contribute the bulk of the output change.

2.3 Integral term

The contribution from the integral term is proportional to both the magnitude of the error and the duration of the error. Summing the instantaneous error over time (integrating the error) gives the accumulated offset that should have been corrected previously. The accumulated error is then multiplied by the integral gain and added to the controller output. The magnitude of the contribution of the integral term to the overall control action is determined by the integral gain, Ki.

The integral term accelerates the movement of the process towards set point and eliminates the residual steady- state error that occurs with a proportional only controller. However, since the integral term is responding to accumulated errors from the past, it can cause the present value to overshoot the set point value.

2.4 Derivative term

The rate of change of the process error is calculated by determining the slope of the error over time and multiplying this rate of change by the derivative gain Kd. The magnitude of the contribution of the derivative term to the overall control action is called the derivative gain, Kd. The derivative term is given by:

$$D_{out} = K_d \frac{de(t)}{dt}$$

The derivative term slows the rate of change of the controller output and this effect is most noticeable close to the controller setpoint. Hence, derivative control is used to reduce the magnitude of the overshoot produced by the

integral component and improve the combined controller-process stability. However, differentiation of a signal amplifies noise and thus this term in the controller is highly sensitive to noise in the error term, and can cause a process to become unstable if the noise and the derivative gain are sufficiently large.

3. MODELING OF BALL AND BEAM SYSTEM

Consider the ball and beam experiment found in many undergraduate control laboratories as shown in figure. The beam is made to rotate in a vertical plane by applying a torque at the center of rotation and the ball free to roll along the beam. We require that the ball remain in contact with the beam and that the rolling occur without slipping, which imposes a constraint on the rotational acceleration of the beam.

Variable and constants are given as follows:

- M mass of the ball 0.11 kg
- R radius of the ball 0.015 m
- d lever arm offset 0.03 m
- g gravitational acceleration 9.8 m/s²
- L length of the beam 1.0 m
- J ball's moment of inertia 9.99e-6 kgm²
- r ball position coordinate
- Alpha beam angle coordinate
- Theta servo gear angle

Let the moment of inertia of the beam be 'J', the mass and moment of inertia of the ball be 'm' and 'Jb', respectively, the radius of the ball be 'R' and the acceleration of gravity be 'g'. Choosing the beam angle 'θ' and the ball position 'r' as generalized position coordinates of the system and 'τ' is the torque applied to beam.

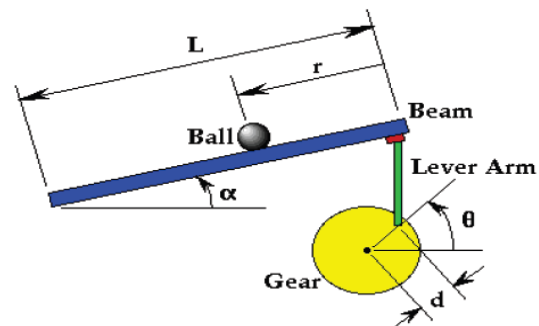

Figure 3 :- Ball and Beam system for mathematical analysis

The liner mathematical model of the plant is:

$$\ddot{x} \left(\frac{J}{r^2} + m \right) + mg \alpha = 0 \quad \text{-----(1)}$$

Euler-Lagrangian equations of motion are given by

$$\left(\frac{J_b}{R^2} + m \right) \ddot{r} + mg \sin \theta - mr(\dot{\theta})^2 = 0 \quad \text{-----(2)}$$

$$(mr^2 + J + J_b)\ddot{\theta} + 2mri\dot{\theta} + mg \cos \theta = \tau \text{ -----(3)}$$

The design criteria for this problem are:
 Settling time less than 3 seconds
 Overshoot less than 5%

The beam angle (alpha) can be expressed in terms of the angle of the gear (theta).

$$\alpha = \frac{d}{L}\theta$$

4. BUILDING A MODEL IN SIMULINK

The proposed model has been simulated using MATLAB Simulation

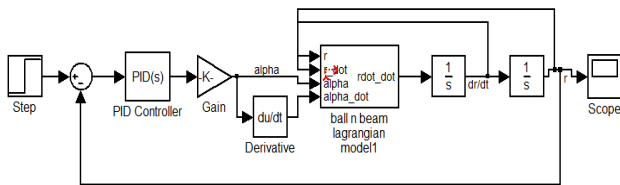

Figure 4:- Simulation model of Ball and Beam system

Figure 4 shows the simulation model of Ball and Beam system, the PID mathematical model developed and using the MATLAB software to simulate and controlled the model.

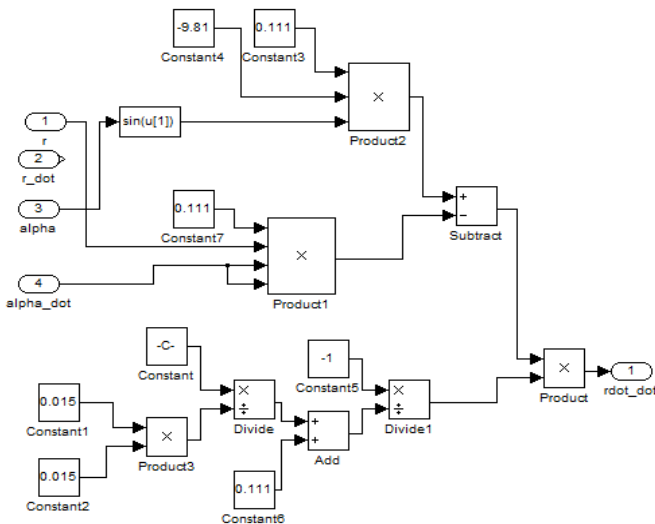

Figure 5:- Internal structure of Ball and Beam model

With the reference of equation no (2) the mathematical model developed and MATLAB software is used to simulate and control the model. The above is the simulation model of the plant.

Following are the parameters tuned to achieve stability of PID controller.

5. SIMULATION RESULT

The ball and beam system model has been simulated using simulink. The value of Kp, Ki and Kd has been adjusted to stable the ball and beam system model.

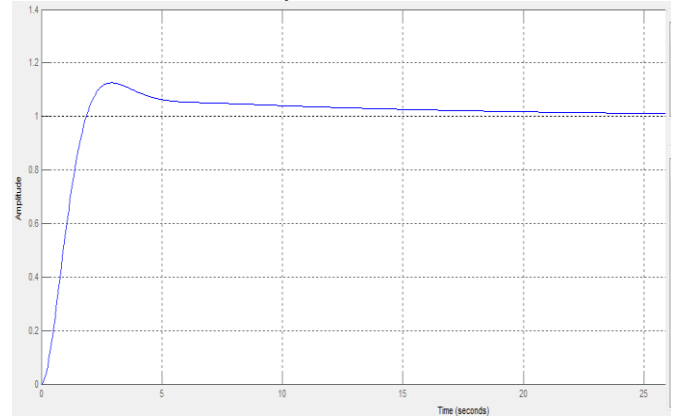

Figure 6:- Simulation results of Ball and Beam Model

The best design criterion is achieved by tuning the value of Kp, Ki and Kd to 0.91, 0.0071 and 10.494 respectively.

REFERENCES

- [1] Mehmet Korkmaz, Omer Aydogdu, Fractional Order Controller Design for Ball and Beam System Applied Mechanics and Materials Vols. 313-314 (2013) pp 544-548
- [2] Chen, Y. Q. (2006), Ubiquitous fractional order controls. In The second IFAC symposium on fractional derivatives and applications (IFAC FDA06), Porto, Portugal.
- [3] Oustaloup A., Levron F., Nanot F., & Mathieu, B. (January 2000), Frequency-band complex noninteger differentiator: Characterization and synthesis. IEEE Transactions on Circuits and Systems I: Fundamental Theory and Applications, 47 (1),25 "U40.
- [4] Barbosa, R. S., Tenreiro, J. A., & Ferreira, I. M. (2003), A fractional calculus perspective of PID tuning. In ASME 2003 design engineering technical conferences and computers and information in engineering conference, Chicago, USA.
- [5] Caponetto R., Fortuna L., & Porto D. (2004), A new tuning strategy for a non-integer order PID controller. First IFAC workshop on fractional differentiation and its application (pp. 168 "U173). Bordeaux, France: ENSEIRB.
- [6] Chen, Y. Q. (2006), Ubiquitous fractional order controls. In The second IFAC symposium on fractional derivatives and applications (IFAC FDA06), Porto, Portugal.