

# Transient Performance of Cascaded Induction Motors Using UPQC

J. Jayashree, B. Balaji, G. Balambiga  
CK College of Engineering and Technology,  
Cuddalore, Tamilnadu, India.

**Abstract** - In this paper, the effect of Unified Power Quality Conditioner (UPQC) on transient performance of Common-Shaft Cascade Induction Motors (CSCIM) are performed and commonly used in deep well digging plant (i.e. oil wells). UPQC analyze these events include system starting, supply voltage sag and swells as well as plugging. Maintaining a power distribution bus voltage near sinusoidal at rated magnitude and frequency is known as power quality. The series converter used for protecting a sensitive load from sag, swell and the parallel converter for power factor correction, load balancing and regulation of bus voltage. The hybrid devices consist of two voltage source converters (VSCs) which are linked through a Direct Current (dc) bus. UPQC is implemented using controllers PI controller, for the purpose of Analyzing the Results. The open loop system and the closed loop system are simulated using Simulink and compared. The simulation results show that the UPQC has a great capability in order to enhance the transient performance .

**Keywords**— *Induction Motors, Voltage-Source Converter (VSC) , Unified Power Quality Conditioner.*

## I. INTRODUCTION

The investigation of the transient behavior of three-phase induction motors has been an attractive subject [1]-[5] for a long time owing to their practical applications in industry. For prediction of transient phenomena, appropriate modeling of induction machines is very important. Several models have been well developed such as phase coordinate and d, q models which have been appeared in classical textbooks [6]-[9]. The technology of the application of power electronics to power distribution networks for the benefit of a customer or a group of customers is known as custom power [10][11]. Under this scheme, a customer receives a pre-specified quality power. Maintaining a power distribution bus voltage near sinusoidal at rated magnitude and frequency is known as power quality. Some objectives of power quality are having no power interruption, having low harmonic voltage, having no flicker in the supply voltage, etc [12]. Custom power devices are categorized in three main types according to their practical structures: a) series devices, b) parallel devices, c) hybrid devices [13]. The series devices are usually employed for protecting a sensitive load from sag, swell, etc. The parallel devices have capabilities for power factor correction, load balancing and regulation of bus voltage. The hybrid devices consist of two voltage source converters (VSCs) which are linked through a direct current (dc) bus [14]. The capabilities of these devices are still unexplored, however they can simultaneously perform the tasks of type a, and type b custom power devices. The unified power quality conditioner (UPQC)

is expected to be one of the most important systems to overcome the power quality problems of distribution systems [15]. According to the basic idea of UPQC, it consists of back-to-back connections of two three-phase VSCs with a common dc link. One of the VSCs is connected in parallel with the utility and is called shunt voltage source converter (i.e. VSC\_SH) and the other is connected in series and is called series voltage source converter (i.e. VSC\_SE). VSC\_SH works as current source and usually compensates for current quality problems of load and the regulation of dc link. VSC\_SE acts as series voltage source to compensate for voltage quality problems of load and sometimes isolates the load from voltage quality problems of utility. In the literature, little attention has been paid to evaluation of the transient performance of common shaft cascade induction motors (CSCIMs) which are widely used in deep well digging schemes, particularly in the oil industry. In [16] evaluation of transient performance of CSCIMs is reported. However, the effects of custom power devices such as UPQC on dynamic and transient behavior of CSCIMs have not seen yet which in fact, our main goal in this paper is. In this paper, some transient events are simulated using MATLAB/Simulink and the results are presented, namely: -System starting. -Supply voltage sag and swell.

## II. OPERATION OF SIMILAR CSCIM

Fig. 1 shows the general schematic diagram of the studied system which consists of n similar CSCIMs. The three-phase stator windings are connected to three-phase main bus (i.e. bus M). Bus M is also supplied by 20/2.3 kV, 15 MVA, D-Y three-phase transformer (T1) which is connected to three-phase feeder via circuit breaker (CB1). T1 is also fed by 2 km, 20 kV three-phase distribution line connected to equivalent 20 kV, 500 MVA source. In the sample system, we also provide the facility in order to connect UPQC for future investigations. In the sample system, the UPQC is energized when CB2 is closed and CB3 is opened. The power electronic bridges of UPQC are connected to the utility through Low Pass Filter (LPF) banks via three-phase coupling transformers (T2 and T3). Fig. 1 also depicts the mass and spring configuration of all rotors in CSCIM scheme and illustrates the mechanical load and shaft stiffness due to different shaft segments.

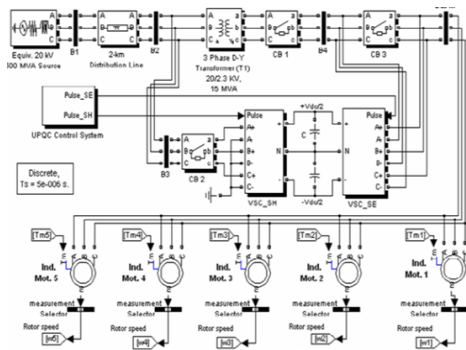

Fig.1 Common Shaft Induction Motors

In present study, it is assumed that there are five similar cascaded motors, and mechanical load is coupled to the fifth motor. There are some methods to calculate the number of motors in cascade scheme. In this section, a simple one is introduced. Using the following notation, it can be shown that the required torque for motor operation of a single machine-load scheme is:

$$Tm = x + y - z \dots\dots\dots 1$$

Where,

J = motor moment of inertia

D = motor viscous friction

K = shaft stiffness factor

$\theta_m$  = motor angular position

$\theta_L$  = load angular position.

For motor operation,  $T_m$  must be positive, so

$$Tm = x + y - z > 0 \dots\dots\dots 2$$

At the other side, in cascaded machines-load scheme, supposing all motors have the same parameters, the required torque for motor operation is,

$$Tm = x + y/n - z/n \dots\dots\dots 3$$

In (3), n is the number of motors in cascade scheme.  $T_m$  must be positive, so from (3) the critical n (i.e.  $n_c$ ) is,

$$n_c = [z - y] / -x \dots\dots\dots 4$$

$$n > n_c$$

In this way, a proper value for n can be selected. Fig. 3.8 illustrates a graphical representation of the motor torque parameters variation with respect to the number of cascaded motors (n).

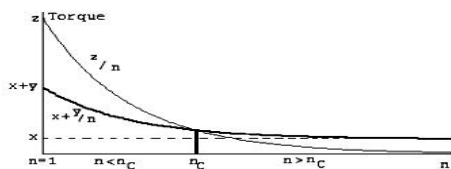

Fig.2. Motor torque variation

### III. B. PROPOSED SYSTEM OF UPQC WITH PI-CONTROLLER

#### A. 1. Need for Controllers

The control system acts as the nervous system for the plant. It provides sensing, analysis, and control of the physical process. When a control system is at properly tuned, the process variability is reduced, efficiency is maximized, energy costs are minimized, and production rates can be increased. Controller tuning refers to the selection of tuning parameters to ensure the best response of the controller.

#### B. 2. Open Loop System

An open-loop controller, also called a non-feedback controller, is a type of controller that computes its input into a system using only the current state and its model of the system.

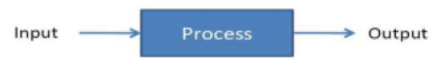

Fig.3 Block diagram of openloop system

A characteristic of the open-loop controller is that it does not use feedback to determine if its output has achieved the desired goal of the input. This means that the system does not observe the output of the processes that it is controlling. Consequently, a true open-loop system can not engage in machine learning and also cannot correct any errors that it could make. It also may not compensate for disturbances in the system.

#### C. 3. Closed Loop System

The systems in which the output quantity has no effect upon the input to the control process are called open-loop control systems, and that open-loop systems are just that, open ended non-feedback systems. But the goal of any electrical or electronic control system is to measure, monitor, and control a process. Some of it back to compare the actual output with the desired output so as to reduce the error and if disturbed, bring the output of the system back to the original or desired response. The measure of the output is called the "feedback signal" and the type of control system which uses feedback signals to control itself is called a Close-loop System.



Fig.4. The block diagram of closed loop Feedback system

#### D.4. Control of UPQC During the Transients

One significant feature of the UPQC is that typically a dc capacitor is connected between the VSCs (voltage source converter), rather than a dc source. Because neither series nor shunt compensators are lossless, a special dc link voltage controller is required to maintain the dc capacitor average voltage at a constant level. In the UPQC, the shunt compensator is usually responsible for this voltage regulation. In the steady state, the average dc link voltage is maintained at a certain preset level, but during the transient this is not the

case. Such a transient can occur when a load is either connected or disconnected to/from the UPQC or a voltage sag/swell on the supply side occurs. Since it takes a finite time interval to calculate the new reference current, the shunt compensator cannot immediately response to the load change. In addition to this, some settling time is required to stabilize the controlled parameter around its reference. Consequently, after a load changing instant there exists some transient period during which the average voltage across the dc capacitor deviates from its reference value.

#### IV. C. PI CONTROLLER

P-I controller is mainly used to eliminate the steady state error resulting from P controller. However, in terms of the speed of the response and overall stability of the system, it has a negative impact. This controller is mostly used in areas where speed of the system is not an issue. Since P-I controller has no ability to predict the future errors of the system it cannot decrease the rise time and eliminate the oscillations. If applied, any amount of I guarantees set point overshoot.

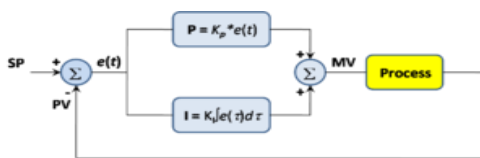

Fig.5. Block diagram of PI controller

A PI Controller (proportional-integral controller) is a special case of the PID controller in which the derivative (D) of the error is not used. The controller output is given by  $Kp\Delta + K1 \int \Delta dt$  .....5

where  $\Delta$  is the error or deviation of actual measured value (PV) from the setpoint (SP).

$$\Delta = SP - PV \dots\dots\dots 6$$

A PI controller can be modelled easily in software such as Simulink or Xcos using a "flow chart" box involving Laplace operators:

$$C = \frac{G(1+Ts)}{Ts} \dots\dots\dots 7$$

Where

$$G = Kp \dots\dots\dots \text{proportional gain}$$

$$G/\tau = Ki \dots\dots\dots \text{integral gain}$$

Setting a value for  $G$  is often a trade off between decreasing overshoot and increasing settling time.

The lack of derivative action may make the system more steady in the steady state in the case of noisy data. This is because derivative action is more sensitive to higher-frequency terms in the inputs.

#### A. 1. The Characteristics of PI- Controller

Among all the type of controllers the PI-controller as a proportional controller ( $K_p$ ) will have the effect of reducing the rise time and will reduce, but never eliminate, the steady-state error. An integral control ( $K_i$ ) will have the effect of

eliminating the steady-state error, but it may make the transient response worse. Among all these types of controllers the PI-controllers plays a leading role eliminates the steady state error and increase the speed response of the system.

#### B. 2. Open Loop Motor Control

The open-loop speed control method for induction motors that provides high output torque and nearly zero steady state speed error at any frequency is presented. The control scheme is based on the popular constant volts per hertz (V/f) method using low cost open- loop current sensors. Advantages of open loop system is Simplicity and stability, they are simpler in their layout and hence are economical and stable too due to their simplicity.

Constructions for these are having a simple layout so are easier to construct. but the Disadvantages of open loop system is Accuracy and Reliability since these systems do not have a feedback mechanism, so they are very inaccurate in terms of result output and hence they are unreliable too.

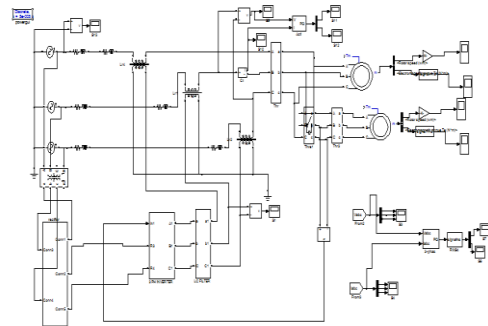

Fig.6 Simulink diagram of system without controller

#### C. 3. Closed Loop Motor Control

A closed-loop motor controller is a common means of maintaining a desired motor speed under varying load conditions by changing the average voltage applied to the input from the controller.

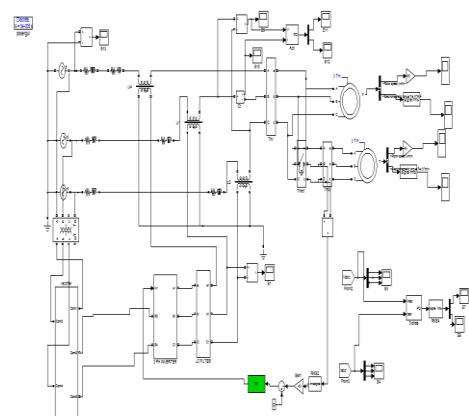

Fig.7 Simulink diagram of the system with PI-controller

Like this way a closed loop is implemented using a type of controller called PI-CONTROLLER. Use of this controller in motor requires only if any external disturbances to the closed-loop motor control system occurs such as the motors load increasing would create a difference in the actual motor speed and the potentiometer input set point.

This difference would produce an error signal which the controller would automatically respond to adjusting the motor's speed. Then the controller works to minimize the error signal, with zero error indicating actual speed which equals set point. In closed loop system the efficiency is increased and transient is minimized by controlling the parameter of motors i.e., speed of the motor, the motor runs reliably even in unstable range. For the implementation of the proposed drive the MATLAB/SIMULINK environment has been used.

### V. D. SIMULATION RESULTS

The simulation results presented in this section are related to transient performance of CSCIMs in presence of UPQC. All results presented for different cases belong to behavior of the system with open loop and closed loop. In this paper a detailed results of system with voltage sag and voltage swell are analyzed based on the Input voltages.

#### A. 1. Results Based on Open Loop System

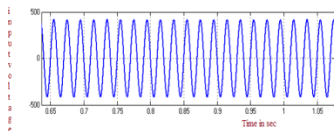

Fig.8 Waveform of input voltage

The above figure shows, the input voltage of the open loop system that is the given voltage is about 415volt.at the time of starting there is no disturbance in the input voltage.

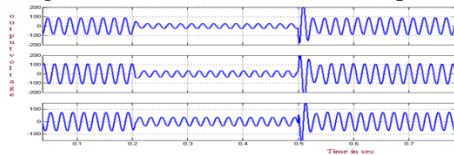

Fig.9 Waveform of output voltage of the system without controller

The above figure shows the output voltage of the system .at the time of starting there is no disturbance after 0.2 sec there is production of sag. this sag continuous from 0.2sec to 0.5sec,at 0.5 sec there is sudden occurrence of swell this sag and swell condition are eliminated by the function of UPQC.

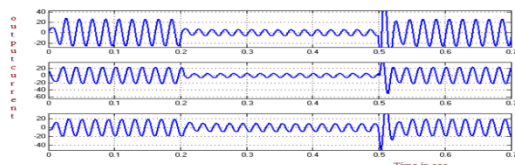

Fig.10 Waveform of Output current without controller

The above figure shows the output current of the open loop system the magnitude of the system is same as that of output voltage only the amplitude varies

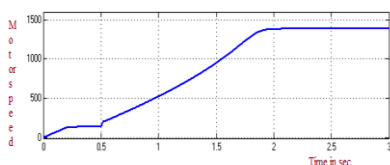

Fig.11 Waveform of Motor speed

The above figure shows the motor speed of the system at the time of starting, the sag condition occurs at 0.2 to 0.5sec the motor produces less amount of speed after 0.5sec there is sudden increase of speed due to swell condition by the function of UPQC the motor runs at constant speed of 1500rpm.

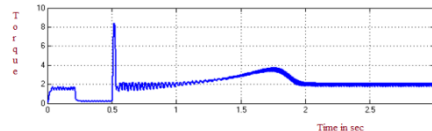

Fig.12 Waveform of Torque

The above figure shows the torque of the motor, the production torque rating is respect to that of motor speed is same after 2sec the UPQC comes into action then the motor runs with rated speed.

#### B. 2. FFT Analysis for Open Loop

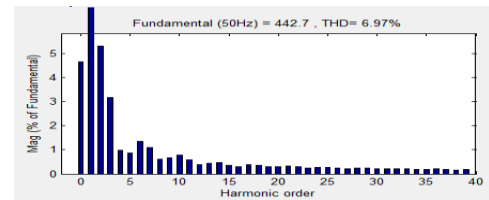

Fig.13 Output voltage of FFT level

FFT analysis value for output voltage ( $V_{abc}$ ) (ie) THD = 0.0697;Therefore, Total Harmonic Distortion (THD) =6.97%

#### C. 3 .Closed Loop System

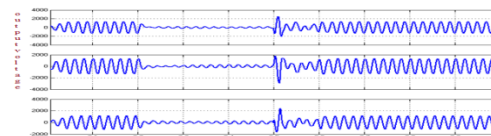

Fig. 14 Waveform of Output voltage

The above figure shows the output voltage of the system .at the time of starting there is no disturbance after 0.2 sec there is production of sag. this sag continuous from 0.2sec to 0.5sec,at 0.5 sec there is sudden occurrence of swell and some sag oscillation between 0.5 to 0.6sec this sag and swell condition are eliminated by the function of UPQC.

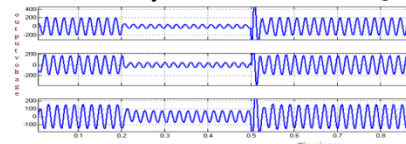

Fig 15 Waveform of Output current

The above figure shows the output current of the closed loop system ,the magnitude of the system is same as that of output voltage only the amplitude of the system at 0.5sec swell condition occurs and these are eliminated by the control action of UPQC varies.

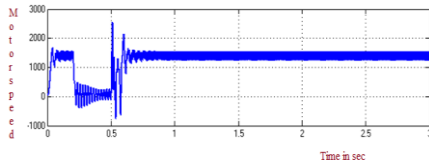

Figure:16 waveform of Motor speed

The above figure shows the motor speed of the system at the time of starting there is sudden increase of speed and slowly decreases due to sag and swell condition. Compared to the previous system the transient condition reduced within 0.8sec by the function of UPQC the motor runs at constant speed of 1500rpm.

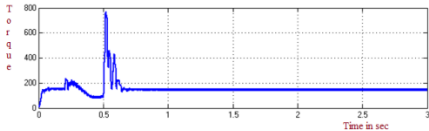

Figure:17 Waveform of Torque

The above figure shows the torque of the motor ,the production torque rating is respect to that of motor speed is same transient condition reduced within 0.8sec the UPQC comes into action then the motor runs with rated speed.

#### D.4.FFT Analysis for Closed Loop

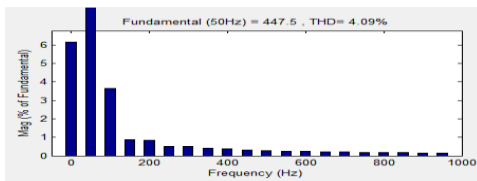

Figure:18 Output voltage of FFT level

FFT analysis value for output voltage ( $V_{abc}$ ) (ie) THD = 0.0409; Therefore, Total Harmonic Distortion (THD) =4.09%

#### VI. E.CONCLUSION

The simulink model of the new Unified Power Quality Conditioner (UPQC) on transient performance of Common-Shaft Cascade Induction Motors (CSCIM) circuits is developed, simulated and implemented. The circuit is analyzed for different criterion and the results are presented. The simulation results of the open loop converter and the closed loop converter with new Unified Power Quality Conditioner (UPQC) on transient performance of Common-Shaft Cascade Induction Motors (CSCIM) are compared and found that the closed loop system has reduced steady state error in the output. The simulation results of the converter are presented. The simulation results are obtained by using MATLAB/Simulink environment.

This project analysis the effect of Unified Power Quality Conditioner (UPQC) on transient performance of Common- Shaft Cascade Induction Motors (CSCIM). This study is based on novel functionalities for UPQC.. The results show that the UPQC has a superior capability in order to analysis the transient performance of CSCIMs. In this a detailed circuit simulation is performed which provides many benefits for complementary designs (e.g. the protection system design and configuration). Design and configuration of the

protection system for the studied cascade scheme can be performed with the use UPQC which is implemented by PI-controller for the above transient condition.

#### REFERENCES

- [1] P.C. Krause, "Simulation of symmetrical induction machinery," IEEE Trans. Power App. Syst., PAS- 84 (1965) 1038- 1053 .
- [2] I.R. Smith and S. Sriharam, "Induction motor reswitching transients," Proc. Inst. Electr.Eng. , 114(1967) 503- 509 .
- [3] A.K. Sarka and G.J. Berg, "Digital simulation of three phase induction motors," IEEE Trans. Power App. Syst., PAS- 89 (1970) 1031 - 1037 .
- [4] G. Nath and G.J. Berg, "Transient analysis of three phase SCR controlled induction motors," IEEE Trans. Ind. Appl., IA- 17(1981) 133 - 142 .
- [5] W.C. Lin, C.E. Lin, C.L. Huang, S.L. Chen and Y.T Wang, "Prediction of the transient performance of induction machines," Electr . P o w e r Syst. Res., 10 (1986) 241- 246 .
- [6] B. Adkins and R.G. Harley, The General Theory of Alternating Current Machines, Chapman and Hall, London, 1975.
- [7] P.C. Krause, Analysis of Electric Machinery. McGraw-Hill, New York, 1986.
- [8] I. Boldea and S.A. Naser, Electrical Machine Dynamics, Macmillan, New York, 1986.
- [9] N.N. Hancock, Matrix Analysis of Electrical Machinery. Pergamon, Oxford, 1974.
- [10] A. Ghosh and G. Ledwich, "A unified power quality conditioner (UPQC) for simultaneous voltage and current compensation," Electr . Power Syst. Res. 59 (2001) 55 - 63
- [11] Y.Y. Kolhatkar and S.P. Das, "Experimental investigation of a single-phase UPQC with minimum VA loading," IEEE trans. Power Del., V o l. 22 , Issue. 1, pp . 373- 380, Jan. 2007
- [12] Y.J. Shin, E.J. Powers, M. Grady and A. Arapostathis, "Power quality indices for transient disturbances," IEEE trans. Power Del., Vol. 21 , Issue. 1, pp . 253- 261, Jan. 2006 .
- [13] H. Fujita and H. Akagi, "The unified power quality conditioner, the integration of series and shunt- active filters," IEEE trans. Power Electron. Vol. 13 , Issue. 2, pp . 315- 322, Mar. 1998.
- [14] B. Han, B. Bae, S. Baek and G. Jang, "New configuration of UPQC for medium-voltage application," IEEE trans. Power Del., V o l. 21 , Issue. 3 .pp . 1438- 1444, Jul. 2006 .
- [15] A.K. Jindal, A. Ghosh and A. Joshi, "Interline unified power quality conditioner," IEEE trans. Power Del. , Vol. 22, Issue. 1 .pp . 364 - 372 , Jan . 2007 .
- [16] M. Abedi, M.R. Maher and R. Madahi, "Evaluation of the transient performance of cascade induction motors," Elsevier, Electr . Power Syst . Res., 32 (1995) 133- 140 .
- [17] Sim Power Systems For Use with Simulink , User's Guide, The Math Works Inc.2006



J. Jayashree is working as Assistance Professor in the dept of EEE at CK College of Engineering and Technology. She received BE in EEE Madurai Kamaraj University, Madurai. ME Embedded system Engineering from GKM Engineering College Chennai. She has been teaching for the past 11 years, and guided more than 100 BE,10 ME students for their projects. She has published 10 papers in national and international journals. She is a Member of IEEE, ISTE, His research interests are in the areas of Embedded system, Digital electronics, and Wireless System.



B. Balaji is working as Assistant Professor in the dept. of EEE at CK College of Engineering and Technology. He received BE in EEE at Anna University, Chennai, ME in Power Electronics and Industrial Drives at Sathyabama University, Chennai. He has been teaching for the past two years and published more than 10 papers in National and International Journals and Conferences. He is a Member of IEEE, ISTE. His research interests include Power Electronics, Renewable Energy, Industrial Motors and Drives.



G. Balambigai is working as an Assistant Professor at CK College of Engineering and Technology. She received BE in EEE at Madras University, Madras, ME Power Electronics and Drives from Anna University. She has been teaching for the past 11 years, and guided more than 100 BE, 10 ME students for their projects. She has published 10 papers in national and international journals. She is a Member of IEEE, ISTE, His research interests are in the areas of Power Electronics, Controller Design, Renewable energy Systems, Industrial Automation..