

System Development to Enhance the Stability of Two Machine Transmission Systems with Static VAR Compensator and Multiband Power System Stabilizer

¹Prof. Aziz Ahmad, ² Asraf Ali

¹(Department of Electrical & Electronics Engineering Al-Flah school of Engineering and Technology dhauj, Faridabad)

² (Department of Electrical & Electronics Engineering Mewat Engineering College (Wakf), Nalla, Nuh, Mewat)

ABSTRACT

The effect of Static Var Compensator (SVC) and multiband Power System Stabilizer (PSS) has not been considered previously for various faults in a three phase system. For improvement in inductive and capacitive power flows Shunt Flexible AC Transmission System (FACTS) devices can be used and when they are placed in the center position of transmission line of a electrical power transmission network. We made models with FACTS devices and also varied their location for reducing fluctuations in voltage and improvement in transient stability power system. We have found that, shunt Static Var Compensator is best this work, so we have continued our research using shunt SVC. Again during our study we have found that if we slightly change the position of FACTS devices towards generator performance of the system improves but it eventually depends on load either local or of overall system. The work described here illustrates modeling of a simple transmission system containing two hydraulic power plants. A static var compensator (SVC) and multiband power system stabilizers (MB-PSS) are used to improve transient stability and power oscillation damping of the system. The power system illustrated in this thesis is quite simple. However, the phasor simulation method allows the user to simulate more complex power grids. We have used MATLAB for the study of the system.

Key words: static Var Compensator (SVC) and Multiband Power System Stabilizers (PSS), Thyristor Controlled Reactor (TCR), Thyristor switch capacitor (TSC) Three phase system.

I. Introduction

The term transient is a short duration high frequency phenomena occur in power system from half an cycle to few second. It is very difficult to maintain the system stability in the age of age of industrialisation and it creates a very dynamic, rapidly changing and complex need of electrical power system with a quality to change automatically according to the requirements of users. This will definitely improve reliability as this system will be less prone to failure and if the system autocorrects itself accurately and quickly then this system which incorporates generation, transmission, distribution and consumption, can provide quality power to the consumers. The FACTS devices are used to change the quality of power delivered by all the required changes required i.e. changing

the voltage, phase or impedance or all of them simultaneously as and wherever required. These devices also have advantage of fast response which again not only improves stability of system but enhanced steady state flow control also. Static Var Compensator (SVC) is the FACTS controller, which provides reactive impedance compensation that's too at very high speed but only for finite length of time but this time is sufficient enough to provide voltage support. Its other advantages are minimization of power fluctuations and reduction in losses. By using MATLAB/SIMULINK I have shown here that Static Var Compensator (SVC) provides reactive compensation dynamically for voltage control fast acting dynamic reactive compensation for voltage support during any sudden change or any unseen event that may reduce voltage quality for a significant time. Here we have modeled various line faults and effect of SVC and MB-PSS to minimize voltage transient. And improve power oscillation damping

II. Introduction to Static Var Compensator

The Static Var Compensator (SVC) is member of the Flexible AC Transmission Systems (FACTS) family and its control circuit is based on power electronics to control power flow and improve transient stability on Power grids [2]. The SVC regulates voltage at its terminals by controlling the amount of reactive power injected into or absorbed from the power system. When system voltage is low, the SVC generates reactive power (SVC capacitive). When system voltage is high, it absorbs reactive power (SVC inductive). The variation of reactive power is performed by switching three-phase capacitor banks and inductor banks connected on the secondary side of a coupling transformer. Each capacitor bank is switched on and off by three thyristor valve (Thyristor Switched Capacitor or TSC). Reactors are either switched on-off (Thyristor Switched Reactor or TSR) or phase-controlled (Thyristor Controlled Reactor TCR). The figure-1 shows a single-line diagram of a static var compensator and a simplified block diagram of its control system

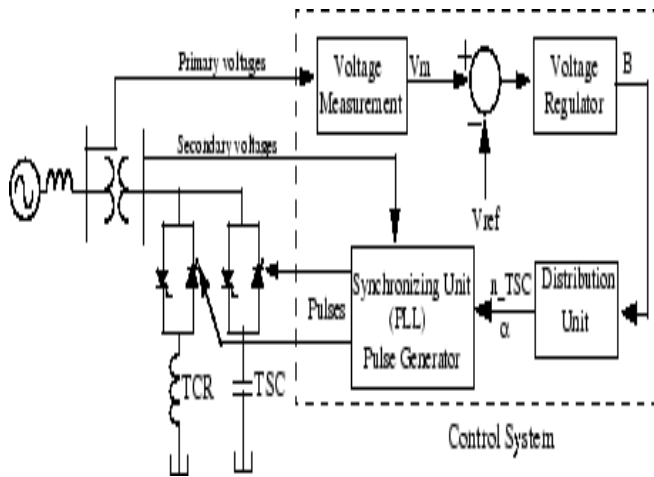

Figure1: Single-line Diagram of an SVC along with Its Control System Block

The control system consists of of SVC

- A measurement system measuring the positive-sequence voltage to be controlled. A Fourier-based measurement system using a one-cycle running average is used.
- A voltage regulator that uses the voltage error (difference between the measured voltage V_m and the reference voltage V_{ref}) to determine the SVC susceptance B needed to keep the system voltage constant
- A distribution unit that determines the TSCs (and eventually TSRs) that must be switched in and out, and computes the firing angle α of TCRs
- A synchronizing system using a phase-locked loop (PLL) synchronized on the secondary voltages and a pulse generator that send appropriate pulses to the thyristors

The SVC (Phasor Type) block is a phasor model, and you must use it with the phasor simulation method, activated with the Powergui block. It can be used in three-phase power systems together with synchronous generators, motors, and dynamic loads to perform transient stability studies and observe impact of the SVC on electromechanical oscillations and transmission capacity [1]. This model does not include detailed representations of the power electronics, the Measurement system or the synchronization system. These systems are approximated rather by simple transfer functions that yield a correct representation at the system's fundamental frequency.

III. Introduction to the Power System Stabilizer (PSS)

The power system stabilizer is basically used to remove the power oscillation in power transmission system and provide the constant output at its terminal. In this thesis Power System Stabilizer (PSS) block can be used to add damping to the rotor oscillations of the synchronous machine by controlling its excitation. The disturbances occurring in a power system induce electromechanical oscillations of

the electrical generators. These oscillations, also called power swings, must be effectively damped to maintain the system stability. The output signal of the PSS is used as an additional input (v_{stab}) to the Excitation System block. The PSS input signal can be either the machine speed deviation, $\Delta\omega$, or its acceleration power, $P_a = P_m - P_e$ (difference between the mechanical power and the electrical power). The Generic Power System Stabilizer introduced by the following nonlinear system shown in figure -2:

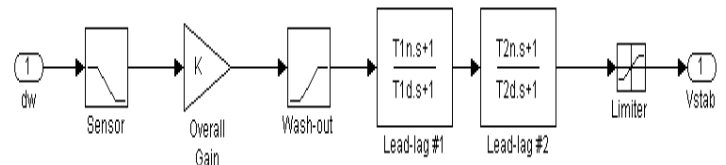

Figure 2: The Generic Power System Stabilizer

To ensure a robust damping, the PSS should provide a moderate phase advance at frequencies of interest in order to compensate for the inherent lag between the field excitation and the electrical torque induced by the PSS action. The model consists of a low-pass filter, a general gain, a washout high-pass filter, a phase-compensation system, and an output limiter. The general gain K determines the amount of damping produced by the stabilizer. The washout high-pass filter eliminates low frequencies that are present in the $\Delta\omega$ signal and allows the PSS to respond only to speed changes. The phase-compensation system is represented by a cascade of two first-order lead-lag transfer functions used to compensate the phase lag between the excitation voltage and the electrical torque of the synchronous machine.

IV. Introduction to Multiband Power System Stabilizer

The multiband power system stabilizer have adjustable working band to control the different mode of oscillation. The disturbances occurring in a power system induce electromechanical oscillations of the electrical generators. These oscillations, also called power swings, must be effectively damped to maintain the system's stability. Electromechanical oscillations can be classified in four main categories:

- Local oscillations: between a unit and the rest of the generating station and between the latter and the rest of the power system. Their frequencies typically range from 0.8 to 4.0 Hz.
- Interplant oscillations: between two electrically close generation plants. Frequencies can vary from 1 to 2 Hz.

- Interarea oscillations: between two major groups of generation plants. Frequencies are typically in a range of 0.2 to 0.8 Hz.
- Global oscillation: characterized by a common in-phase oscillation of all generators as found on an isolated system. The frequency of such a global mode is typically under 0.2 Hz.

The need for effective damping of such a wide range, almost two decades, of electromechanical oscillations motivated the concept of the multiband power system stabilizer (MB-PSS). As its name reveals, the MB-PSS structure is based on multiple working bands. Three separate bands are used, respectively dedicated to the low-, intermediate-, and high-frequency modes of oscillations: the low band is typically associated with the power system global mode, the intermediate with the interarea modes, and the high with the local modes. Each of the three bands is made of a differential band pass filter, a gain, and a limiter (see the figure 3 which is Conceptual Representation). The outputs of the three bands are summed and passed through a final limiter producing the stabilizer output V_{stab} . This signal then modulates the set point of the generator voltage regulator so as to improve the damping of the electromechanical oscillations. To ensure robust damping, the MB-PSS should include a moderate phase advance at all frequencies of interest to compensate for the inherent lag between the field excitation and the electrical torque induced by the MB-PSS action.

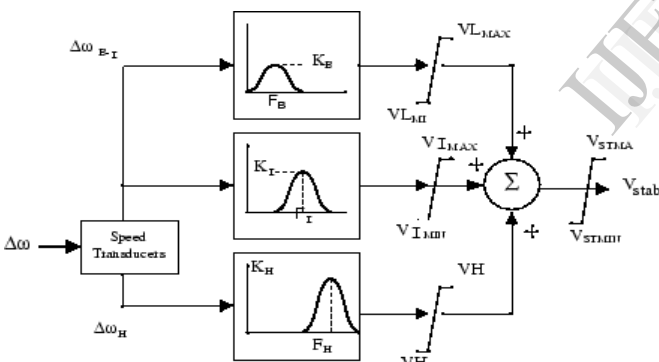

Figure 3: Conceptual Representation

Results & Discussion Circuit Description:

A 1000 MW hydraulic generation plant (machine M1) is connected to a load center through a long 500 kV, 700 km transmission line. The load center is modelled by a 5000 MW resistive load. The load is fed by the remote 1000 MW plant and a local generation of 5000 MW (machine M2). The system has been initialized so that the line carries 950 MW which is close to its surge impedance loading (SIL = 977 MW). In order to maintain system stability after faults, the transmission line is shunt compensated at its center by a 200-Mvar Static Var Compenstor (SVC). Notice that this SVC model is a phasor model valid only for transient stability solution. The SVC does not have a Power Oscillation Dampng (POD) unit. The two machines are equipped with a Hydraulic Turbine and Governor (HTG), Excitation system and Power System Stabilizer (PSS). These blocks are located in the two

'Turbine and Regulator' subsystems. Two types of stabilizers can be selected: a generic model using the acceleration power ($P_a =$ difference between mechanical power P_m and output electrical power P_{eo}) and a Multi-band stabilizer using the speed deviation (dw). The stabilizer type can be selected by specifying a value (0=No PSS 1= P_a PSS or 2= dw MB PSS) in the PSS constant block. During this you will apply faults on the 500 kV systems and observe the impact of the PSS and SVC on system stability.

V. The impact of Three-phase SVC and two PSS system on three phase fault

We will now apply a 3-phase fault and observe the impact of the SVC for stabilizing the network during a severe contingency. Put the two PSS (P_a type) in service (value=1 in the PSS constant block. Reprogram the 'Fault Breaker' block in order to apply a 3-phase-to-ground fault. Verify that the SVC is in fixed susceptance mode with $B_{ref} = 0$. Start the simulation. By looking at the $d_theta_{1,2}$ signal, you should observe that the two machines quickly fall out of synchronism after fault clearing. In order not to pursue unnecessary simulation, the Simulink 'Stop' block is used to stop the simulation when the angle difference reaches 3×360 degrees. Now open the SVC block menu and change the SVC mode of operation to 'Voltage regulation'. The SVC will now try to support the voltage by injecting reactive power on the line when the voltage is lower than the reference voltage (1.009 pu). The chosen SVC reference voltage corresponds to the bus voltage with the SVC out of service. In steady state the SVC will therefore be 'floating' and waiting for voltage compensation when Voltage departs from its reference set point.

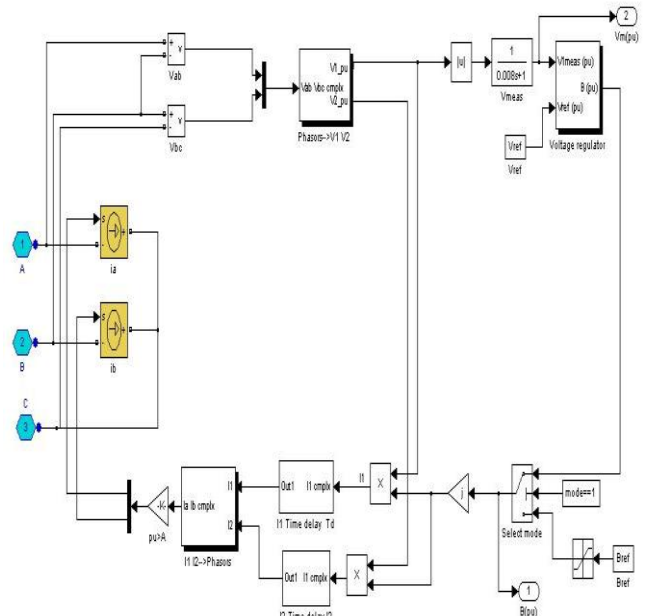

Figure 4: Two machine SVC/PSS subsystem

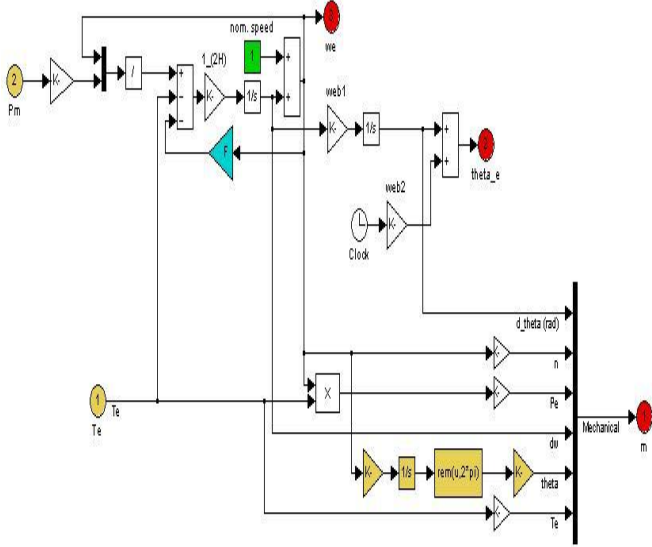

Figure-5: Mechanical Parts of a three phase synchronous Machine

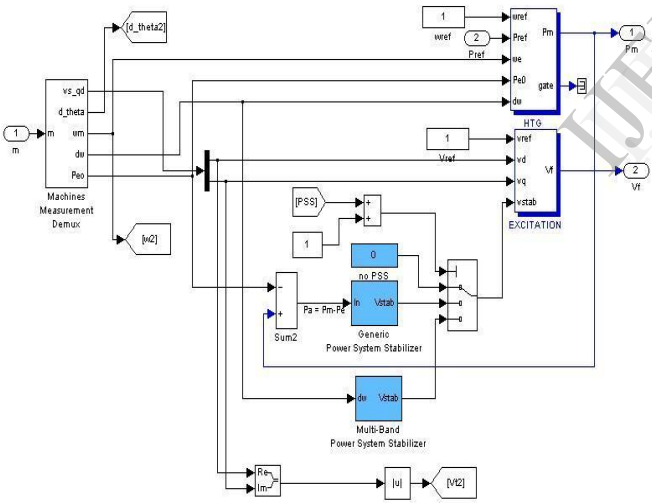

Figure 6: Two machine SVC/PSS turbine regulator Subsystem

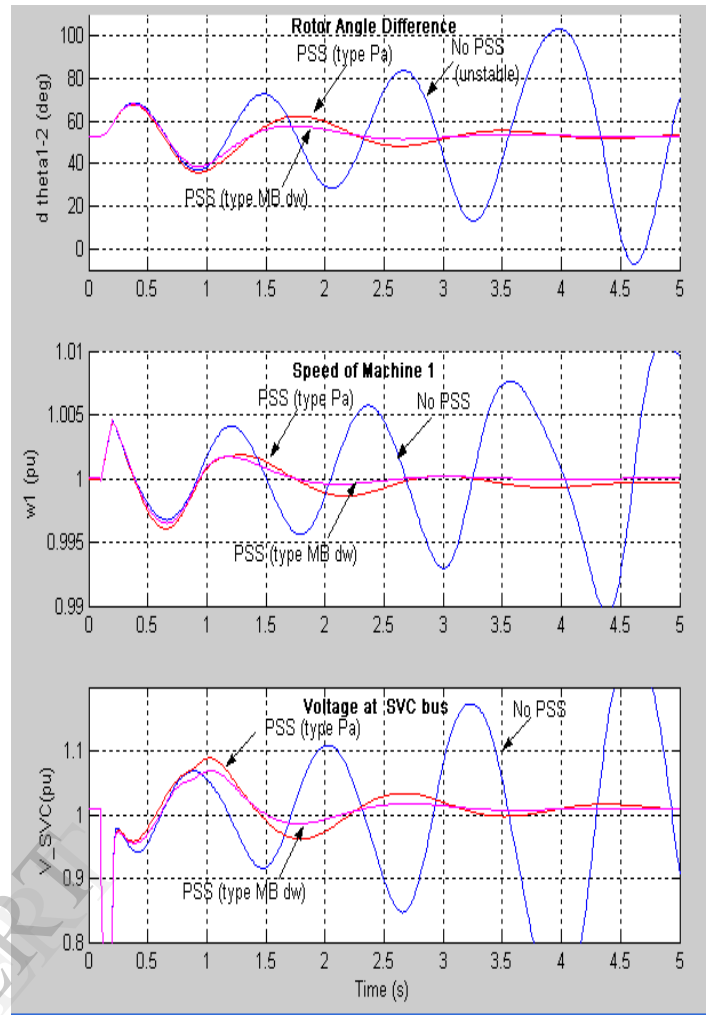

Figure 7. Impact of single band and multiband power system stabilizer

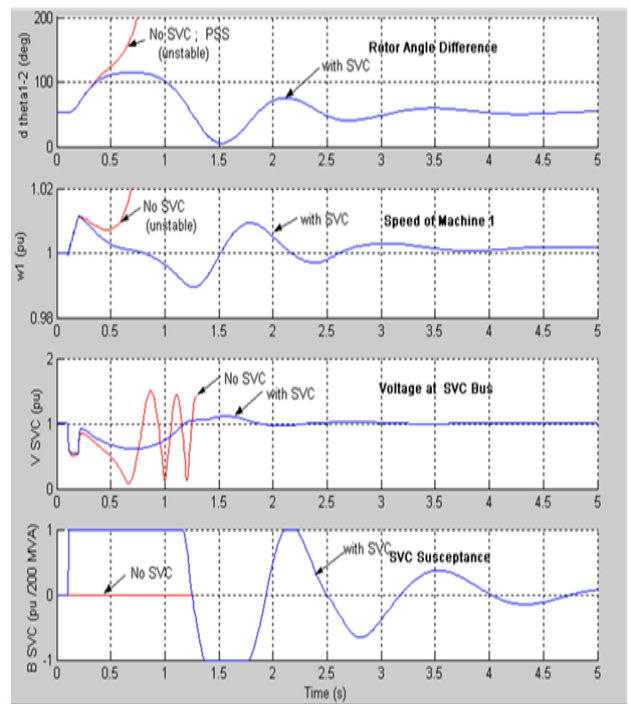

Figure 8: Comparison of results of a 6 cycle 3 phase Fault when PSS in service and with and without SVC

In this work, the efficiency of shunt FACTS devices such as SVC was studied for improvement of the systems transient stability of a sample transmission system containing two-machine system with different studies and investigation. The response of SVC to transients due to various faults in the three phases to ground was investigated.

VI. Conclusion

The work described in this thesis shows modeling of a transmission system with two hydraulic power plants. A static var compensator (SVC) and multi band power system stabilizers (MB-PSS) are used to improve systems transient stability and power oscillation damping of the power system. The power system describe in this thesis is quite simple. However, the phasor simulation method allows the user to simulate more complex power grids. The results show that the system has been developed successfully for the stability of transients in a two-machine transmission system with MB-PSS and SVC.

References

- [1] P. Kundur, Power System Stability and Control. New York: McGraw-Hill, 1994.
- [2] Journal of Electrical Systems Science and Engineering, Vol. 1, No. 1, pp. 1-8, 2008.
- [3] N. G. Hingorani, L. Gyugyi, Understanding FACTS: Concepts and Technology of Flexible AC Transmission Siddhartha Panda and N.P.Padhy, "Robust power system stabilizer design using particle swarm optimization technique", International Systems, IEEE Press, New York, 2000.
- [4] Y. H Song, T. A. Johns, Flexible AC Transmission Systems (FACTS), IEE, London, 2000.
- [5] R. M Mathur, R. K. Verma, Thyristor-based FACTS Controllers for Electrical Transmission Systems, IEEE Press, Piscataway, 2002.
- [6] L. Gyugyi, "Reactive power generation and control by thyristor circuits" IEEE Trans. Industrial Applications, Vol. IA-15, No.-5, pp.521-532, Sept./Oct. 1979.
- [7] L. Gyugyi, "Power electronics in electric utilities: static var compensators," IEEE Proceedings, vol.76, No. 4, pp. 483-494, April 1988.
- [8] Acha, E., V.G. Agelidis, O. Anaya-Lara and T.J.E. Miller, 2002. Power Electronic Control in Electrical Systems, Newnes Power. Engineering Series.

Author



ASRAF ALI received his B.Tech with honour's in Electronics & communication Engineering .Now he is pursuing M.Tech. in power system (EEE Deptt.) at AL-FALAH school of Engineering and Technology Dhauj, Faridabad Haryana. He has his research Interests in the field of F.A.C.T device, and communication system.He has total 6- year experience in the field teaching and industrial.

Guide



AZIZ AHMAD received his B.Tech degree in Electrical Engg. And the M.E. degree in Control and Instrumentation Engg. From Jamia university And now he is pursuing his Ph.D.degree in control system from Jamia University NEW Delhi. He has total 14-years teaching experience.Now he is working as a Professor and Head of Electrical and Electronics Engineering department at AL-FALAH school of Engg. & Technology Dhauj, Faridabad Haryana. His research interests include F.A.C.T system, Control system and Instrumentation Engg.