

# Synchronization of Three Phase Inverter with Electrical Grid

Mr. Rajan J. Devi,

Associate Professor (Electronics), Department of Electronics Engineering; Karmaveer Bhaurao Patil College of Engineering, Satara, Dist-SATARA; 415001 Maharashtra, India.

Miss. Supriya S. Kadam,

M. E. Electronics (II), Department of Electronics Engineering; Karmaveer Bhaurao Patil College of Engineering, Satara, Dist-SATARA; 415001, Maharashtra, India.

**Abstract** - Phase, frequency, and amplitude of phase voltages are the most important and basic parameters need to be controlled or grid-connected applications. The aim of this paper is to present a review of various synchronization techniques for pulse width modulated voltage source inverter. This paper describes the estimation method and verifies its usefulness by extensive numerical experiments. Various synchronization algorithms are described here. The primary application of the proposed synchronization methods is for the distributed generation units with renewable energy sources, which utilize power electronic converters as an integral part of their systems. The synchronization is usually carried out with respect to the voltage, frequency and phase angle of voltage (or current) signal(s) of the utility system. The paper also describes the issues, challenges & solutions for.

**Index Terms**- Microgrid, Inverter, Synchronization, Amplitude, frequency and phase control.

## I. INTRODUCTION

A Microgrid is an aggregation of multiple distributed generators (DGs), such as renewable energy sources, conventional generators, and energy storage systems etc. Typically, a Microgrid operates in parallel with the main grid. However, in some situation a Microgrid need to operate in an islanded mode, or in a standalone state. Islanded distributed generators (DGs) in a Microgrid can change its operational mode to grid connected operation by reconnection to the grid, which is referred to as synchronization. A Microgrid or a portion of the power grid which consists of load and distributed generator (DG) system; it can be isolated from Grid. In this situation, it is important for the Microgrid to continue to provide adequate power to the load under standard supply conditions. In various circumstances, if fault conditions occur in the grid, then the Microgrid is expected to isolate from the main grid, each distributed generators (DGs) of inverter system must detect this islanding situation and must switch to a voltage control mode. However, the synchronization of Microgrids that operate with multiple distributed generators (DGs) and loads cannot be controlled by a traditional synchronizer. It is needed to control multiple generators and energy storage systems in a coordinated way for the Microgrid synchronization. In ideal condition, the output voltage parameters like amplitude, frequency and phase cannot be controlled for a grid together where multiple DGs are working in parallel; whereas the same parameters for stand alone

inverter to be connected to grid, can be controlled by means of the various control strategies[1]-[8].

In order to provide the required load voltage, inverter system works in standalone mode or grid connected mode. In load scheduling condition or grid off condition, the inverters works in standalone mode and provide the required power to the load. Being major of the power available through renewable systems is in DC form, inverters are preferred instead of alternators. Parameters of the inverter such as voltage, frequency and phase can be controlled for the purpose of synchronization with the relevant parameters of the grid system. Synchronization of inverter parameters like voltage, frequency and phase with grid systems can be possible by specific control system with embedded controller. To meet the load sharing requirement, the output from the inverter system can be varied with synchronization of grid system. The system presented here is a DC to AC inverter controlled using a compact controller based on an embedded system and that can be synchronized with the grid system [9]-[12].

Various techniques of synchronization of the inverter are described in the second section named as literature review. Proposed system for synchronization of inverter with electrical grid is described in Methodology section. Experimentation and Results are discussed in next section.

## II. LITERATURE REVIEW

In sinusoidal pulse width modulation, there are multiple pulses per half-cycle and the width of the each pulse is varied with respect to the sine wave magnitude. Pure sine wave DC/AC conversion will introduce the least amount of harmonics into an electrical system, but these methods are also expensive. Since the AC sine wave to come from a DC source, the static devices will be switched in a logical way such that the energy delivered to a load approaches that of a pure sine wave. This means that extra components and design considerations are involved in the control circuitry of a pure sine wave inverter, driving up cost. A more precise method of DC/AC conversion is the modified sine wave, which introduces a dead time in a normal square wave output so that higher peak voltages can be used to produce the same average voltage as a sinusoidal output. This method produces fewer harmonics than square wave generation, but it still is not quite the same as the AC power that comes from an AC

outlet. The harmonics that are still present in a modified sine wave make modified sine wave inverters unsuitable for use while electrical noise is a concern. With proper selection of switching states, it is possible to obtain synchronization and symmetry in the space vector pulse width modulation (SVPWM) algorithm. This is standard approach without any additional computational requirements or feedback signals. This synchronization algorithm can be used for open-loop constant v/f drives. Further implementation is modified synchronized space vector pulse width modulation (SVPWM) algorithm for three level voltage source inverter (VSI) with Synchronized and Symmetrical Waveforms achieved by maintaining the synchronization, half-wave symmetry, quarter-wave symmetry, and three-phase symmetry in the pulse width modulation (PWM) waveforms. For three level inverters, the principles of achieving synchronization and symmetries in terms of space vectors are presented. Another approach is shifted synchronized space vector pulse width modulation (SVPWM). This method is used to Control DC-Link Resonant Inverters. Its FPGA Realization increase the switching frequency of the inverter, also it reduces the switching frequency of the dc-link resonant circuit. It can improve the utility of the dc-link voltage [1]-[5].

Robust Line-Voltage sensor less Control and synchronization of LCL-Filtered Distributed Generation Inverters for High Power Quality Grid Connection proposed control scheme facilitates line-voltage sensor less current control and grid-synchronization performance. This scheme providing robust and simple active damping control performance under grid and filter parameter variation; suppression of grid induced distortion without a-prior knowledge of the grid background distortion and unbalance via real-time generation of the frequency modes and disturbances that should be eliminated from the closed-loop current control system; robust deadbeat digital control performance that maximizes the dynamic performance of the converter; and robustness against interaction dynamics between active damping and current tracking controllers [6]. A Robust Natural-Frame-Based Interfacing Scheme for Grid-Connected Distributed Generation Inverters control scheme estimated uncertainty dynamics provide the necessary energy shaping in the inverter control voltage to attenuate grid-voltage disturbances and other voltage disturbances caused by interfacing parameter variation. The Neural Networks (NN) adaptation algorithm allows feasible and easy adaptation design at different grid disturbances and operating conditions. The converter synchronization is based on the fundamental grid voltage facilitates the use of the estimated uncertainty to extract the position of the fundamental grid-voltage vector without using voltage sensors [7].

Practical Implementation of PWM Synchronization and Phase-Shift Method for Cascaded H-Bridge Multilevel Inverters (HBML) are based on a Standard Serial Communication Protocol. In addition, it is very difficult to obtain high speed and reliable bidirectional communication using conventional user-defined methods, which can cause the overall system to be unreliable. For this method, the performance and reliability of conventional distributed controllers for HBML inverters can be improved with less

communication hardware requirements since individual inverter modules operate more independently [8].

A Novel Communication Strategy for Decentralized Control of Paralleled Multi-Inverter Systems suggests the method of synchronization of three inverters. For this method, the common mode signal's circuit in the paralleled system is used as a channel of communication between individual inverters. One inverter module acts as a source where the synchronization between the modules achieved by means of frequency modulation via the common mode current. Each module will then receive and transform the signal to be used as a synchronized voltage command for individual inverters. This method is not affected by external factors such as load change, output voltage variation, and different types of loads [9].

Parallel-Inverter System, with failure isolation and Hot-Swap Features, is controlled with a system control unit to achieve output voltage regulation, inverter synchronization. Parallel operation of inverters to obtain large power capacity, to increase maintainability, and to improve reliability becomes the trend of power system design. The proposed instantaneous voltage and current controller for the parallel-inverter systems with the highest current control can quickly eliminate current deviation and achieve power balance among inverters. The failure isolation feature is achieved with a scanning circuit, a resistor-capacitor filter, and transistors, which are also used in achieving the hot-swap one [10].

Multilayer Control for Inverters in Parallel Operation without intercommunications proposed for inverters, which are able to operate in parallel without inter communications. In this paper, by using the hierarchical control approach, a multilayer wireless control for three phase inverters in parallel operation is achieved. A small-signal model has been developed for adjusting the main control parameters [11].

Self-Synchronized Synchronverters: Inverters without a dedicated synchronization unit used to improve the Synchronverters as a self-synchronized Synchronverters by removing the dedicated synchronization unit. As a result, grid-connected renewable energy and distributed generation can easily take part in the regulation of system frequency and voltage. It can automatically synchronize itself with the grid before connection and track the grid frequency after connection. Similar to other grid-connected inverters, it needs a dedicated synchronization unit, e.g., a phase-locked loop (PLL), to provide the phase, frequency, and amplitude of the grid voltage as references [12].

Power-Synchronization Control of Grid-Connected Voltage-Source converters state a novel control method of grid-connected voltage-source converters (VSCs) which can be generally applied in high-voltage dc (HVDC) applications. This method utilizes the internal synchronization mechanism in ac system similar to the operation of a synchronous machine. By using the power-synchronization control method, VSC-HVDC operates almost in the same way as a synchronous machine. Therefore, in principle, it has no requirement on the short-circuit capacity of the ac system to be connected. On the other hand, VSC-HVDC gives the weak ac system strong voltage support, just like a normal

synchronous machine does. However, a weak ac system connection still represents a more challenging operating condition for VSC-HVDC than a strong ac system connection due to the relatively higher load angles [13]. Grid Synchronization of Power Converters using Multiple Second Order Generalized Integrators presents Multiple Second Order Generalized Integrators (MSOGI) which is frequency-adaptive by using a frequency-locked loop (FLL). For grid-connected power converters, it allows estimating the positive and negative sequence components of the power signal at the fundamental frequency and other sequence components at higher frequencies. It is concept in grid-synchronization of power converters under unbalanced and distorted operating conditions. The MSOGI-FLL consists of multiple DSOIGs (SOGI-QSGs in the case of single-phase systems) tuned at different harmonics of the fundamental grid frequency (from 1 to n). The MSOGI-FLL only uses one FLL, which is connected to the DSOIG tuned at the fundamental frequency. MSOGI-FLL is a very suitable solution to the detection of fundamental-frequency positive- and negative-sequence components of unbalanced and distorted grid voltages [14]. Grid synchronization and symmetrical components extraction with PLL algorithm for grid connected power electronic converters – a review, reviewed three synchronization techniques such as Dual Second Order Generalized Integrator (DSOGI-PLL), Dual Virtual Flux – both in stationary coordinates. In this paper, a review of Phase Locked Loop (PLL) algorithms and symmetrical component extraction methods intended for grid-connected power electronic converters are presented. Proposed classification is based on voltage representation in three coordinates: natural (abc), stationary ( $\alpha\beta$ ) and rotating coordinates (dq). The third one, in rotating dq coordinates, is Dual Synchronous Reference Frame PLL (DSRF-PLL). A comparison of PLL algorithms is presented [15].

PLL synchronization in grid-connected converters by Evgenije Adzic, Vlado Porobic, Boris Dumnic, Nikola Celanovic and Vladimir Katic presents proper PLL parameter selection method for real grid voltage conditions. Renewable power generation systems utilizing power electronics converters rely on accurate grid phase angle determination in order to successfully close grid voltage vector oriented control loop usual for this kind of application. Phase-locked loop (PLL) is the most common method for determination of the grid voltage phase angle and frequency. However, there are still serious limitations of reported PLL algorithms in real grid voltage conditions (unbalance and distortion). This paper presents proper PLL parameter selection method for real grid voltage conditions [16]. Analysis of SDFT based phase detection system for grid synchronization of distributed generation system by Chitti Babu, K Shridharan, Eugeniusz Rosolowski and Zbigniew Leonowics proposed phase detection system for DG system based on Sliding Discrete Fourier Transform (SDFT). This paper explores phase detection of DG is robust phase tracking capability with fast transient response under adverse situation of grid [17]. A New Synchronization Algorithm for Grid-Connected Inverters proposed Synchronization algorithms are of great importance in control of grid-connected inverters as an integral part of distributed power generation units such as

photovoltaic systems. A new all-digital closed-loop phase-locked algorithm for the synchronization signals of three-phase grid-connected inverters is presented even considering seriously distorted and variable-frequency utility conditions. The proposed synchronization algorithm can suppress the negative sequence utility voltage at fundamental frequency and high-frequency harmonic components effectively, and lock the positive sequence phase at fundamental frequency accurately [18].

An economical approach of designing a three phase grid tied inverter for solar applications demonstrate the economization of designing a SPWM by replacing an analog transformer by digital counters. An attempt is made in this paper to demonstrate the economization of designing a SPWM by replacing an analog transformer by digital counters. The internal architecture of three phase inverter includes Gate driver, Sinusoidal Pulse Width Modulation (SPWM), Phase locked loop (PLL), low pass filter, snubber circuit. As the PLL topology is matched, the synchronization of inverter with grid is virtually realized [19].

Grid Synchronization by Estimation of Positive Sequence Component in Three Phase Signals uses the enhanced synchronization structure the fundamental positive-sequence component of grid voltages in asymmetric and distorted three-phase systems. Using the enhanced synchronization structure the fundamental positive-sequence component of grid voltages in asymmetric and distorted three-phase systems is estimated. The  $\alpha\text{-}\beta$  stationary frame is used to obtain the pulsation for grid inverter using a space vector pulse width modulation (SVPWM) [20]. Design of Three Phase PWM Voltage Source Inverter for Photovoltaic Application presents the three phase DC-AC inverter mainly used in high power application. This paper presents the three phases DC-AC inverter mainly used in high power application such as induction motor, air-conditioner and ventilation fans, in industries in solar power plants. The three phase inverters commonly used to supply three-phase loads by means of separate single-phase inverters [21].

A New Synchronization Method for Distributed Power System proposed the method achieves synchronization of incoming units without any interruption in power flow or any phase shift. In this process, there is no communication between the inverter units, and the incoming units take over system load in proportion with their power rating [22]. Performance of Grid Connected DG Inverter System by Using Intelligent Controllers represents the control techniques required for Microgrid operation and implementation of a simple control strategy in a Microgrid model realized with MATLAB. The paper presented involves the control techniques required for microgrid operation and implementation of a simple control strategy in a Microgrid model realized with MATLAB [23]. This paper presents a review of several synchronization algorithms used in Grid-Connected Renewable Agents [24]. Overview of Control and Grid Synchronization for Distributed Power Generation Systems gives an overview of the structures for the DPGS along with control structures of the grid-side converter are presented, and the possibility of compensation for low-order harmonics. Due to the increasing number of DPGSS connected to the utility network, new and stricter standards in

respect to power quality, safe running, and islanding protection are issued. As a consequence, the control of distributed generation systems should be improved to meet the requirements for grid interconnection [25].

High Efficiency THIPWM Three-Phase Inverter for Grid Connected System presents enhanced phase-locked loop (EPLL) system. Third harmonic injection PWM (THIPWM) was employed to reduce the total harmonic distortion and for maximum use of the voltage source. DSP was used to generate the accurate THIPWM for grid connection, by synchronizing the inverter voltage with the grid voltage. The application of THIPWM to parallel connected inverter reduces the total harmonic distortion and increases efficiency of the inverter [26]. Power-Synchronization Control of Grid-Connected Voltage-Source Converters represented the novel control method for synchronization. In this paper, a novel control method of grid-connected voltage-source converters (VSCs) is proposed. The method can be generally applied for all grid-connected VSCs but may be of most importance in high-voltage dc (HVDC) applications. This method utilizes the internal synchronization mechanism in ac systems, in principle, similar to the operation of a synchronous machine. By using this type of power-synchronization control, the VSC avoids the instability caused by a standard phase-locked loop in a weak ac-system connection [27].

### III. METHODOLOGY

#### A. Proposed System

To synchronize Distributed Generators (DGs) with the grid, it is necessary to match the parameters of electrical grid system with the inverter system. Implementation of synchronization algorithms is proposed with an embedded system and simulated and tested for the results. The inverter system is proposed to be controlled by ARM based microcontroller, with on chip PWM generator for gate control of inverters. Three phase inverter output controlled by the Sine Pulse Width Modulated (SPWM) pulses generated by the embedded system and gate driver circuit. The block diagram of the proposed work for embedded system based controller for synchronization of three phase bridge inverter system with electrical grid is shown in Figure.1:- Three phase AC supply (Grid) parameters like voltage, frequency and phase are given to embedded controller. Embedded controller consists of ARM based microcontroller with on chip peripherals for driving inverter. Control parameters are provided to the controller. Synchronization algorithm is used to generate the PWM pulses-

Generated PWM output pulses are given to MOSFET/IGBT driver and bootstrap circuit to drive three phase bridge inverter system. The inverter will be generating electrical power in ready for synchronization with electrical grid. The feedback is provided from output of three phase bridge inverter like amplitude, frequency and phase to embedded controller along with similar grid parameters. Embedded system synchronizes the parameters of three phase

bridge inverter system with grid parameters respectively and generates the PWM pulses for three phase inverter accordingly. Continuous comparison and matching between the grid parameters and inverter parameters is done by embedded system controller. LCD display interface is proposed to display the status of various parameters and synchronization. This is realized in this proposed work by using embedded system.

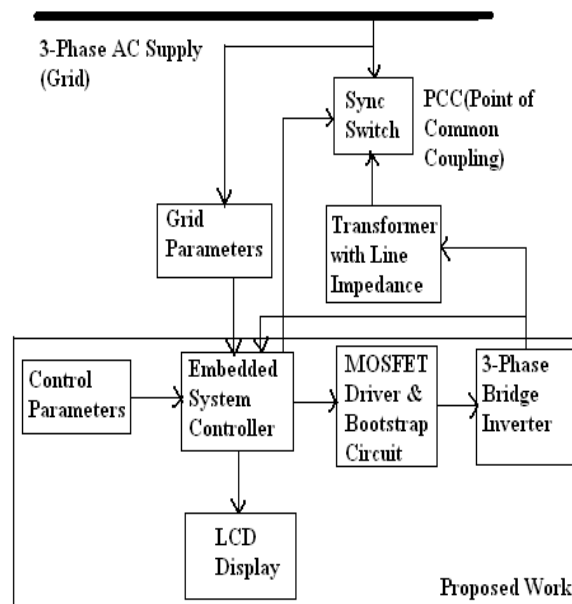

Figure 1. Single Line diagram of grid interface and Block diagram of proposed work

#### B. SIMULATION

Figure 2. shows the MATLAB simulation model block diagram for the proposed system. Grid source is three phase AC supply. It having amplitudes ( $V_a=230$ ,  $V_b=230$  and  $V_c=230$ ), frequencies ( $F_a=F_b=F_c=50\text{Hz}$ ) and phases ( $V_{a0}=0$ ,  $V_{b0} = -120^\circ$ ,  $V_{c0}=+120^\circ$ ). Three phase voltage generated by grid is shown in figure 3. Load voltage for the grid system is shown in figure 4.

Control system receives signals from grid such as  $V_{abc}$ ,  $I_{abc}$  and  $V_{dc}$  for control system. Control system Algorithm contains Anti-Aliasing filters, controller & PWM modulator. Anti-aliasing filter takes inputs  $V_{abc}$ ,  $I_{abc}$  &  $V_{dc}$ . Filtered output passes through the zero-order hold & provided to the controller. Controller receives the reference inputs  $V_{dc\_ref}$  &  $I_{q\_ref}$  if required.

Controller generates two outputs such as Modulation index ( $m$ ) & Phase ( $\phi$  (deg)). This signals given to PWM Modulator along with  $V_{abc\_Sync}$  (Grid output voltage). PWM Modulator provides 6 pulses for three phase inverter switches which shown in figure 5.

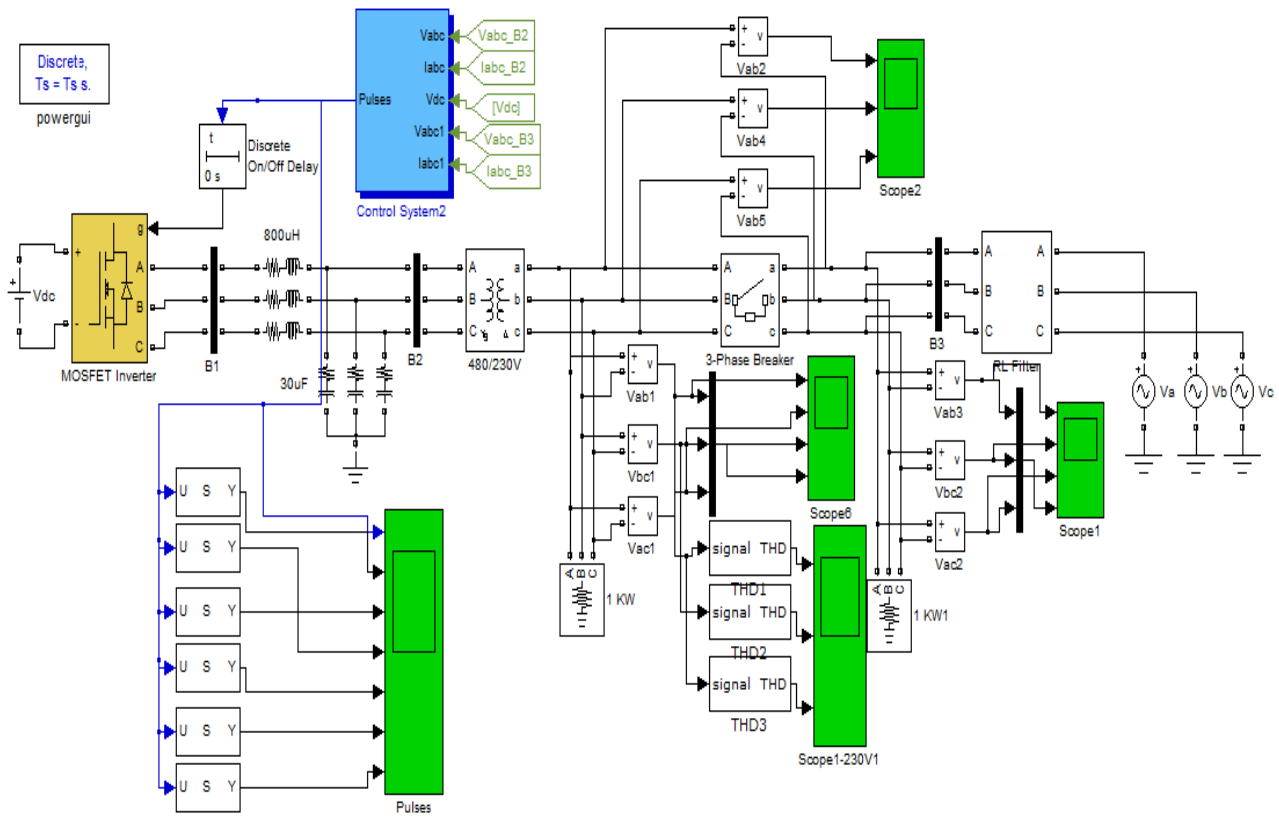

Figure2. MATLAB Simulation Model

In controller, PLL receives Vabc signal from the grid & provide signal to Park transformation (abc to dq0 transformation). Park transformation gives signal IdIq. DC voltage regulator provides Id\_ref which multiplexed with Iq\_ref & gives to current regulator. Current regulator generates output VdVq based on IdIq & IdIq\_ref. Vd\_Vq to m,phi converter given below in detail. Compensating phase shift of anti-aliasing filters at 50 Hz added with phi signal & it generates phi (deg) signal.

$$Vd = \frac{2}{3} * [Va \sin wt + Vb \sin (wt - 2 * \frac{\pi}{3}) + Vc \sin (wt + 2\pi/3)]$$

$$Vq = \frac{2}{3} * [Va \cos wt + Vb \cos (wt - 2 * \frac{\pi}{3}) + Vc \cos (wt + \frac{2\pi}{3})]$$

$$Vo = \frac{1}{3} * [Va + Vb + Vc]$$

$$m = demux[sqrt[u(1)*u(1)+u(2)*u(2)],atan2[u(2)+1e-6,u(1)] * \frac{180}{\pi}]$$

$$\phi^{\circ} = demux[sqrt[u(1)*u(1)+u(2)*u(2)],atan2[u(2)+1e-6,u(1)] * 180/\pi] + 2.4$$

$$Pulses = m[\sin(\omega t + K\phi)] + \sin(\omega t + K\phi - 2 * \pi/3) + \sin(\omega t + K\phi + 2 * \pi/3)$$

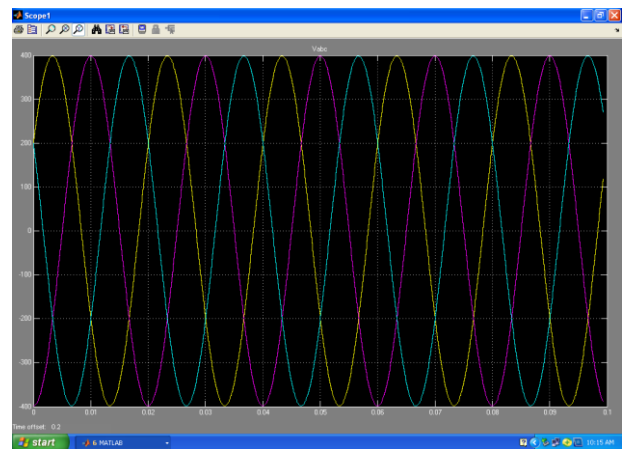

Figure3. Three phase voltage of Grid in MATLAB Simulation

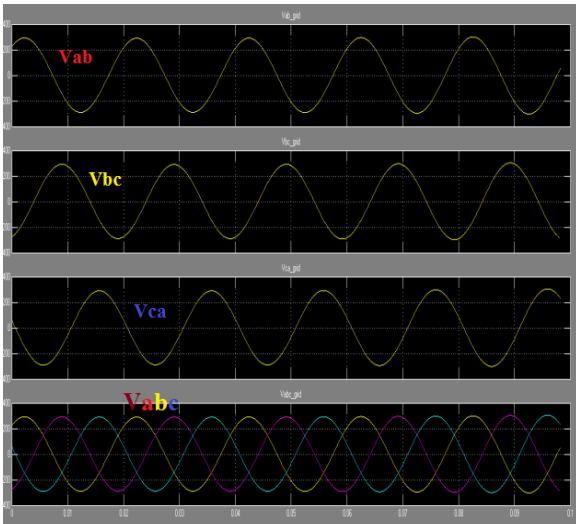

Figure.4.Three phase voltages of Grid across load in MATLAB Simulation

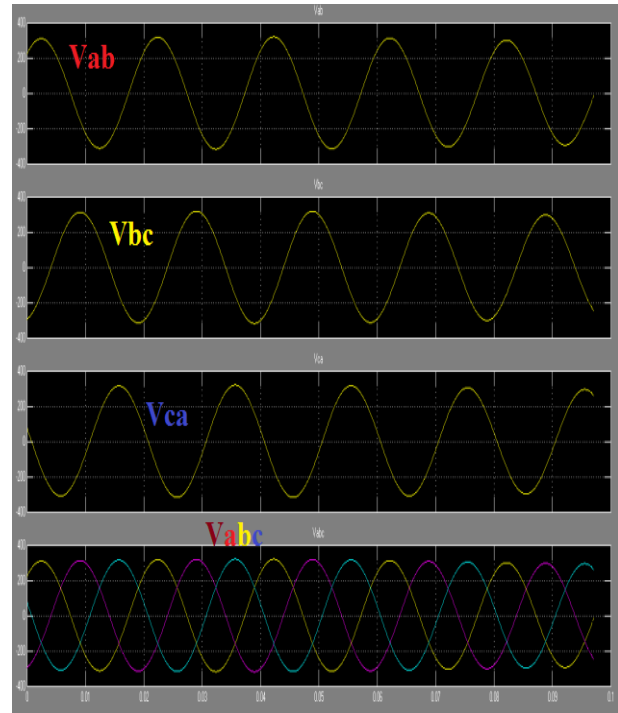

Figure .6.Three phase voltages of Inverter across Load in MATLAB Simulation

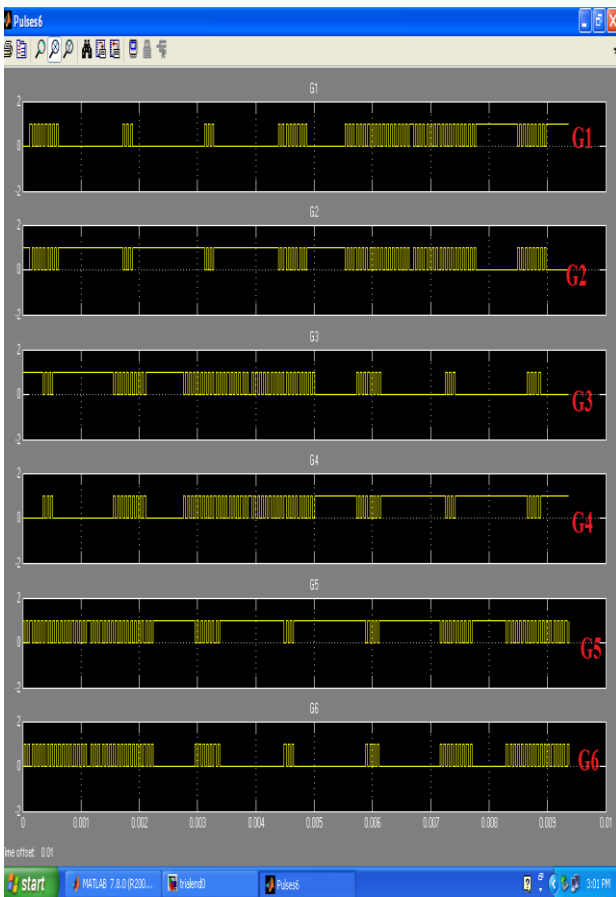

Figure.5.PWM Pulses generated by control algorithm in MATLAB Simulation

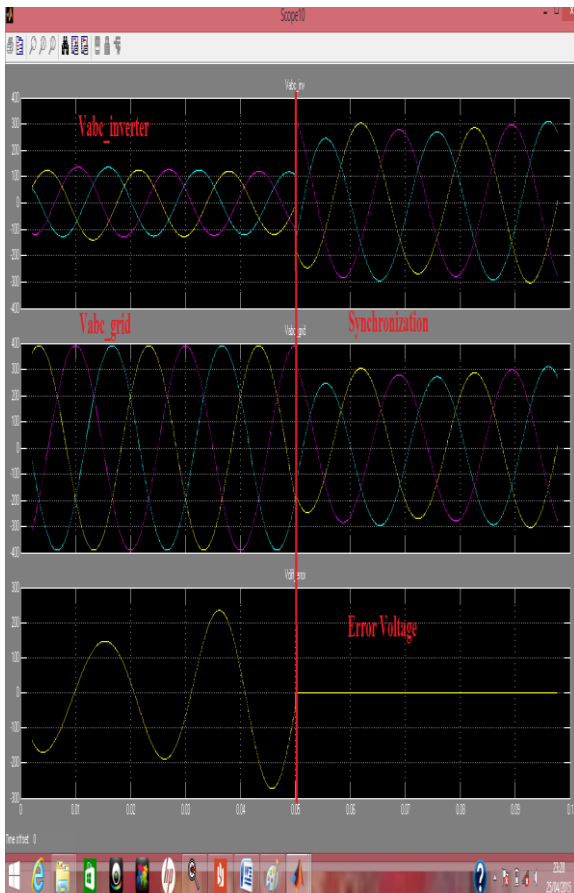

Figure.7. Synchronization of Grid and Three phase Inverter in MATLAB Simulation

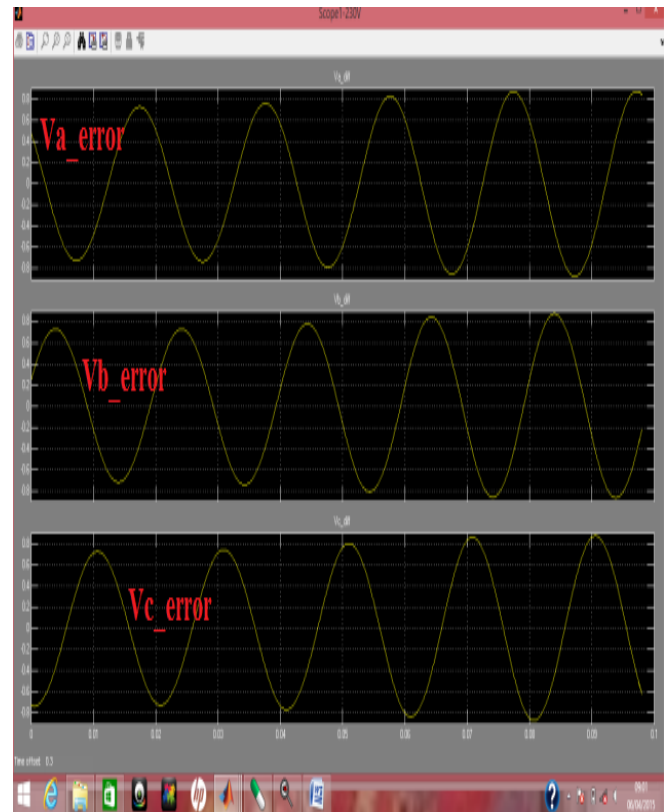

Figure.9. Error voltage between synchronization of Grid and Three phase Inverter in MATLAB Simulation

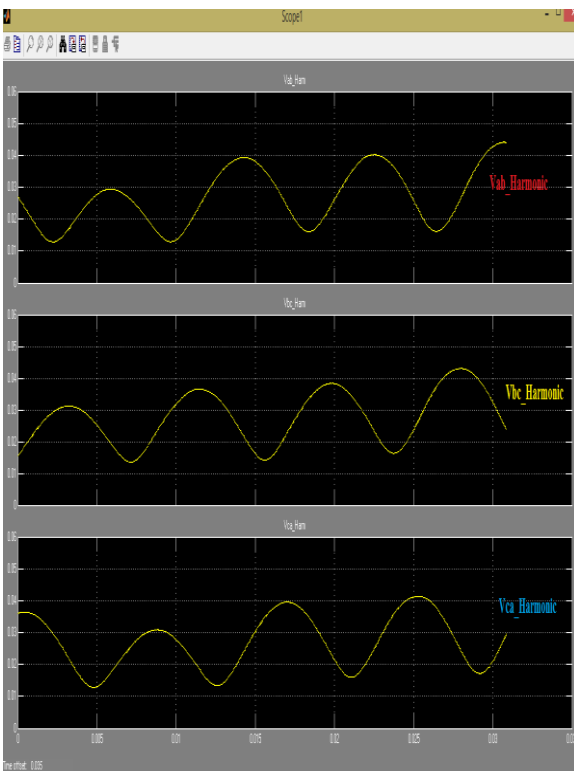

Figure.8. Harmonic Distortion in Three phase Inverter Output in MATLAB Simulation

Three Phase inverter provide the output voltage on the basis of PWM Pulses generated by control algorithm. Figure.6. show the three phase inverter output across the Load. Synchronization between grid voltage and three phase voltage along with difference (1.6 volt) for 230Volt, 50Hz is shown in figure 7. Total Harmonic Distortion contained in the three phase output shown in Figure 8. Phase wise. Resultant Harmonics contained in the three phase output voltage is in between 0.1 to 0.3. Figure 8. shows the synchronization between grid and three phase inverter system. As operating voltage increases along with operating frequencies, the error voltage also increases by 0.25 factors. Figure.9. shows the error voltage between grid and three phase Inverter at proposed ready for synchronization state, in MATLAB Simulation.

#### IV .CONCLUSION

The Microgrid inverter can operate both in the islanded and grid-connected mode. Grid-interfaced Distributed Generators (DGs) can be improving power quality and reliability in power systems. When a fault occurs someplace in the grids, Microgrids need to operate independently from the grid to supply uninterrupted power to the loads. The control method used to improve the performance of Microgrids by coordinating the output power of multiple DGs in Microgrids for the two considerations of operation (i.e., integration of multiple DGs and autonomous island operation) and by optimizing the control parameters. It

is needed to control multiple generators and energy storage systems in a coordinated way for the Microgrid synchronization. An embedded system for synchronization of inverter with electrical grid allows the synchronization between the grid parameters & inverter parameters such as voltage, frequency and phase. Microcontroller generates PWM pulses on the basis of synchronization algorithm. Inverter parameters operate on the PWM pulses can be interface with grid system by using transformer with line impedance.

#### V.ACKNOWLEDGMENT

I am using this opportunity to express my gratitude to everyone who supported me for writing this research paper. I am thankful for their guidance and invaluable advice during this work. I am sincerely grateful to them for sharing their truthful and illuminating views on a number of issues related to this paper.

I express my warm thanks to Mr. Rajan J. Devi for his support and guidance at Department of Electronics Engineering; Karmaveer Bhaurao Patil College of Engineering, Satara, 415001; Maharashtra, India.

#### REFERENCES

- [1]. Yop Chung, Wenxin Liu, David A. Cartes, Emmanuel G. Collins and Seung-Il Moon, "Control Methods of Inverter-Interfaced Distributed Generators in a Microgrid System", IEEE transactions on industry applications, vol. 46, no. 3, May/June 2010.
- [2]. Emanuel Serban and Helmine Serban "A Control Strategy for a Distributed Power generation Microgrid Application With Voltage and Current-Controlled Source Converter" IEEE transactions on power electronics, vol. 25, no. 12, December 2010.
- [3]. Abdul Rahiman Beig, "Synchronized SVPWM Algorithm for the Over modulation Region of a Low Switching Frequency Medium-Voltage Three-Level VSI", IEEE transactions on industrial electronics, vol. 59, no. 12, pp.4545-4554, December 2012.
- [4]. Abdul Rahiman Beig, G. Narayanan and V. T. Ranganathan, "Modified SVPWM Algorithm for Three Level VSI with Synchronized and Symmetrical Waveforms", IEEE transactions on industrial electronics, vol. 54, no. 1, pp. 486-4 94, February 2007.
- [5]. Sanbo Pan, Junmin Pan, and Zuohua Tian, "A Shifted SVPWM Method to Control DC-Link Resonant Inverters and Its FPGA Realization", IEEE transactions on industrial electronics, vol. 59, no. 9, pp. 3383-3391, September 2012.
- [6]. Yasser Abdel-Rady I. Mohamed and Ehab F. El-Saadany, "A Robust Natural-Frame-Based Interfacing Scheme for Grid-Connected Distributed Generation Inverters", IEEE transactions on energy conversion, vol. 26, no. 3, pp.634-643, September 2011.
- [7]. Yasser Abdel-Rady I. Mohamed, M. A.-Rahman and R. Seethapathy, "Robust Line-Voltage Sensorless Control and Synchronization of LCL-Filtered Distributed Generation Inverters for High Power Quality Grid Connection", Yasser Abdel-Rady I. Mohamed, M.A.-Rahman, and R. Seethapathy, IEEE transactions on power electronics, vol. 27, no. 1, pp.87-98, January 2012.
- [8]. Young-Min Park, Ji-Yoon Yoo and Sang-Bin Lee, "Practical Implementation of PWM Synchronization and Phase-Shift Method for Cascaded H-Bridge Multilevel Inverters Based on a Standard Serial Communication Protocol", IEEE transactions on industry applications, vol. 44, no. 2, pp.728-736, March/April 2008.
- [9]. Yeong Jia Cheng and Eng Kian Kenneth Sng, "A Novel Communication Strategy for Decentralized Control of Paralleled Multi-Inverter-Systems", IEEE transactions on power electronics, vol. 21, no. 1, pp.148-156, January 2006.
- [10]. Tsai-Fu Wu, Senior, Hui-Ming Hsieh, Yu-En Wu, and Yu-Kai Chen, "Parallel- Inverter System with Failure Isolation and Hot-Swap Features", IEEE transactions on industry applications, vol. 43, no. 5, pp. 1329-1340, September/October 2007.
- [11]. Ming Hua, Haibing Hu, Yan Xing and Josep M. Guerrero, "Multilayer Control for Inverters in Parallel Operation without Intercommunications", IEEE transactions on power electronics, vol. 27, no. 8, pp.3651-3663, August 2012.
- [12]. Qing-Chang Zhong, Phi-Long Nguyen, Zhenyu Ma, and Wanxing Sheng, "Self- Synchronized Synchronverters: Inverters Without a Dedicated Synchronization Unit", IEEE transactions on power electronics, vol. 29, no. 2, pp.617-630, February 2014.
- [13]. Lidong Zhang, Lennart Harnefors and Hans-Peter Nee, "Power-Synchronization Control of Grid-Connected Voltage-Source Converters", IEEE transactions on power systems, vol. 25, no. 2 , pp.809-820, May 2010.
- [14]. P. Rodríguez Ç, A. Luna Ç, I. Candela Ç, R. Teodorescu È, and F. Blaabjerg È Ç "Grid Synchronization of Power Converters using Multiple Second Order Generalized Integrators" Catalonia Aalborg University Barcelona, Spain.
- [15]. M. bobrowska-rafal\*, k. rafal, m. jasiniski, and m.p. kazmier KOWSKI, "Grid synchronization and symmetrical components extraction with PLL algorithm for grid connected power electronic converters – a review", Warsaw University of Technology, 75 Koszykowa St., 00-662 Warsaw, Poland.
- [16]. Evgenije Adzic, Vlado Porobic, Boris Dumnic, Nikola Celanovic, Vladimir Katic, "PLL synchronization in grid- connected converters", University of Novi Sad, Novi Sad, Serbia, Paper No. T.12-1.1, pp. 1-5, The 6th PSU-UNS International Conference on Engineering and Technology (ICET-2013), Novi Sad, Serbia, May 15-17, 2013.
- [17]. A Chitti Babu, K Shridharan, Eugeniusz Rosolowski and Zbigniew Leonowics, "Analysis of SDFT based phase detection system for grid synchronization of distributed generation system", an international journal of Engineering Science & technology, pp-270-278, 2014.
- [18]. Xiaorui Guo\* and Jifeng Guo, "A New Synchronization Algorithm for Grid-Connected Inverters", An International Journal of Applied Mathematics & Information Sciences, No. 2, pp.869-875 ,2014.
- [19]. G Suresh Babu1, U K Choudhury, G Tulasiram Das and A Mahesh Kumar, "An economical approach of designing a three phase grid tied inverter for solar applications", An international journal of Electrical & Electronics Engineering and Telecommunication, Volume No.1, October 2012.
- [20]. S.Manoharan, Dr.K.Gnanambal , R. Girija, K.P.Ram Prasath, "Grid Synchronization by Estimation of Positive Sequence Component in Three Phase Signals", International Journal of Innovative Research in Science, Engineering and Technology, Volume 3, Special Issue 3, March 2014.
- [21]. Bandana Bhutia, Dr. S.M.Ali, Narayan Tiadi , " Design of Three Phase PWM Voltage Source Inverter For Photovoltaic Application "International journal of innovative research in electrical, electronics, instrumentation and control engineering , Vol. 2, Issue 4, April 2014.
- [22]. Koray Şener Parlak, "A New Synchronization Method for Distributed Power System", Department of Electronics Technologies, Technical Science School, Firat University, Elazığ, Turkey, May 2010.
- [23]. K. Manohar, M. Venu Gopala Rao, "Performance of Grid Connected DG Inverter System by Using Intelligent Controllers "International Journal of Modern Engineering Research (IJMER) ,Vol.2, Issue.3, pp-1119-1124 , May-June 2012.
- [24]. N. F. Guerrero-Rodríguez, Alexis B. Rey-Boué, A. Rigas and V. kleftakis , "Review of Synchronization Algorithms used in Grid-Connected Renewable Agents" International Conference on Renewable Energies and Power Quality (ICREPQ'14) Cordoba (Spain), 8th to 10th April, 2014.
- [25]. Frede Blaabjerg, Remus Teodorescu, Marco Liserre and Adrian V. Timbus, "Overview of Control and Grid Synchronization for Distributed Power Generation Systems", IEEE transactions on industrial electronics, vol. 53, no. 5, pp.1398-1409, October 2006.
- [26]. M.A.A. Younis, N. A. Rahim and S. Mekhilef, "High Efficiency THIPWM Three-Phase Inverter for Grid Connected System", Dept. of Electrical Power Engineering, Uniten, Selangor, Malaysia.
- [27]. Lidong Zhang, Lennart Harnefors and Hans-Peter Nee, "Power-Synchronization Control of Grid-Connected Voltage-Source Converters", IEEE transactions on power systems, vol. 25, no. 2, pp.809-820, May 2010.