

# Sustainable Hydroponic Farming: Intelligent Automation and Monitoring

Shreyas Kadam, Yogesh Kadlag, Krishi Varada, Jay Patel, Dr. R.R. Itkarkar  
Department of Electronics and Telecommunication Engineering, AISMSS College of Engineering, Pune

**Abstract** - The paper presents an intelligent hydroponic farming system that is integrated with automation and real-time monitoring using an ESP32 microcontroller. The system utilizes various sensors which includes DHT22 for temperature and humidity, pH and TDS sensors for nutrient analysis, and a water level sensor for monitoring the water level. An automated pump mechanism is implemented to maintain optimal water level by refilling the water tank when depletion in water level is detected by water level sensor. The data collected is then transmitted to the Blynk IoT platform, which enables real-time monitoring and alerts through a mobile application. The proposed system minimizes manual intervention, improves efficient use of resources, and it also supports sustainable agriculture.

**Keywords** – Hydroponics, ESP32, IoT, Blynk, Water Level Sensor, Automation.

## I. INTRODUCTION

### A. Background and Significance

Agriculture plays a vital role in providing sufficient food supply; however, the agricultural industry has been undergoing many challenges because of the increased rate of urbanization, decreasing amount of agricultural lands, water shortages, and variability in climatic conditions. Traditional soil farming practices have proven to be inefficient, resource intensive, and require much more space for cultivation. Hydroponics is a farming practice in which plants are grown without soil in aqueous solutions containing essential nutrients and is considered a potential technology. It involves space efficiency and allows growing crops in controlled environments irrespective of their soil conditions [1], [2].

There are numerous benefits offered by the hydroponic system, such as fast growth of plants, high productivity in terms of yield, and independence from climatic conditions. There are studies suggesting that hydroponics offers high efficiency of water consumption while ensuring the right nutrient intake by the plants [3], [4].

### B. Problem Statement

While hydroponics possesses many merits, its operation necessitates the exact maintenance of the environment and nutrient parameters, including temperature, humidity, pH level, nutrient strength (TDS), and moisture. Any discrepancy within the above-stated parameters adversely affects crop growth and productivity [5]. Conventional hydroponics depends on manual adjustments to monitor the environment and nutrients, which are inefficient, time-consuming, and error-prone [5].

Another difficulty within hydroponics involves the regulation of a constant nutrient solution level. In conventional hydroponics, there exists no automation to regulate the level of moisture; thus, the level fluctuates and affects plant health and

production. Real-time monitoring and alerts are nonexistent in conventional hydroponics, which further diminishes their efficiency [6].

### C. Review of Existing Systems

The modern developments in smart agriculture have enabled the introduction of IoT based hydroponics using sensors and microcontroller for monitoring purposes. There have been various works where systems were designed which monitor temperature, humidity, pH, TDS and water levels with the help of sensor nodes [1], [7]. Such systems have used platforms like Blynk as well as cloud-based monitoring systems for visualization purposes [8].

There are automated hydroponics as well which try to decrease human involvement in the entire process of farming using automatic water and nutrient supply mechanisms along with controlling the environmental factors. Moreover, some advanced versions of such systems use machine learning to optimize the nutrient delivery and predict plant needs [9], [10]. The solutions for vertical farming further ensure high productivity due to efficient space utilization [11], [12].

Most of these systems concentrate only on monitoring and do not offer complete automation. Also, features like automatic water refilling, low cost, and simple implementation procedures are generally missing from most of the available designs. Furthermore, systems with advanced technologies and algorithms tend to become expensive to implement [6], [13].

### D. Research Gap

As has been seen from the review of the available literature, there is a need for a system incorporating real-time monitoring, automation, and cost-effectiveness. Most of the systems have achieved real-time monitoring of the environmental factors, but only few incorporate the automation of control measures like maintenance of water levels. Furthermore, some systems require the use of costly hardware and sophisticated architecture.

The development of an integrated system that involves the use of sensors together with the Internet of Things technology for real-time monitoring and notification is another area worth consideration. Such an innovation is necessary to improve hydroponics systems and make them applicable in small-scale and urban agriculture settings [5], [14].

### E. Objectives and Contribution

The main aim of this project is to design an intelligent, economic, and fully automated hydroponics setup using the ESP32 microcontroller. This involves using several types of sensors such as DHT22 sensor for temperature and humidity

sensing, pH sensor, TDS sensors, and water level sensor for nutrient measurement and sensing respectively.

An automatic pump system has been designed in this project to ensure that the water levels remain at optimum levels and refill the nutrient solution automatically as and when required. Further, the use of the Blynk Internet of Things (IoT) framework will enable users to monitor and get alerts remotely using the mobile application.

The main contributions of this paper include:

- Retrieval of real-time data about hydroponics
- Use of sensor-based automation for controlling water levels
- Integrating the IoT framework for remote monitoring and alerts
- Economical design of the entire system

## II. LITERATURE SURVEY

The integration of IoT technologies has recently been explored in hydroponic farming with the aim of increasing automation and system efficiency. The use of sensors in hydroponic systems has been extensively examined due to their ability to monitor the important parameters such as temperature, humidity, pH value, and the nutrient concentration in order to ensure the optimum plant growth conditions [1].

Different proposals for designing IoT-based monitoring systems using microcontrollers and sensors for data collection have been proposed for hydroponics in recent times. Such systems enable remote monitoring of plant conditions by means of data transmission to cloud platforms or smartphones, thus greatly decreasing manual work required [2]. Different platforms like Blynk have been found effective in terms of visual representation of data and monitoring of hydroponic systems [2].

Moreover, automated hydroponic systems using actuators such as pumps and relays have been proposed for hydroponics to increase precision and minimize human intervention. Such systems are controlled through sensors and maintain the optimum conditions required for plant growth [3]. Real-time monitoring systems are considered to be more efficient than manual monitoring as they conserve resources [5].

The more advanced methods make use of machine learning algorithms for optimizing the hydroponic system. The system is able to monitor the data from sensors and make adjustments accordingly to meet the needs for nutrients and other environmental factors that result in increased yields and efficient use of resources [4], [10]. In addition to this, there are intelligent monitoring systems that can detect any imbalance in nutrients and alert automatically [13].

Another innovative technology that uses hydroponics is vertical farming. It involves growing plants vertically and is useful in overcoming the problem of lack of space in cities. They make use of vertical growth and controlled environments which allow plants to be grown throughout the year [11], [12]. There is also emphasis laid on the requirement of controlling the environment to allow proper absorption of nutrients and growth of plants [8].

Some shortcomings of these systems include that most of them only include monitoring facilities but not the entire process of hydroponics including automatic regulation of water

levels [6]. Another limitation is that they are complicated and expensive to operate and use [14]. Current used methodology

### A. Overview of Existing System

The current systems that employ hydroponics mainly concentrate on monitoring environmental and nutritional parameters by means of simple sensors and microcontrollers. In these systems, parameters such as temperature, humidity, pH levels, and nutrient concentrations (TDS) are measured to ensure ideal growing conditions [1]. The data obtained by the sensors may be displayed locally or uploaded to the cloud-based platform [2].

### B. Monitoring- Based Approaches

Many of today's systems are primarily meant for monitoring as opposed to full automation. These systems constantly gather data and update their users about it via IoT-based or mobile apps. This enables users to make decisions on how to correct the situation manually [2]. Despite improving the level of awareness significantly, these systems continue to rely heavily on human intervention.

### C. Semi-Automated Systems

In some cases, there are systems that have been developed using minimal automation where the device will automatically turn on and off depending on the threshold level. For instance, an irrigation system can be set to automatically turn on and off when the moisture level or nutrients are at certain levels [3].

Machine learning is also another technology that has been applied for the development of systems where analysis of historical data is used to enhance performance and crop production [4].

### D. Limitations of Existing Systems

Even with all the advancements made in technology, some constraints exist in the contemporary hydroponics systems:

- Failure to adopt total automation, particularly in the regulation of water levels
- Requiring human intervention to adjust system parameters
- Not incorporating real-time alert and controls
- Costly and complex in advanced systems
- Unreliable nutrients delivery owing to the lack of an automatic refill mechanism

Most systems only concentrate on monitoring without implementing feedback control systems that are very critical in ensuring stability [5], [6].

### E. Need of Improvement

Based on the analysis of current methodologies, it can be stated that a system capable of integrating both real-time monitoring and intelligent automation is necessary. For an effective hydroponic system, besides monitoring, automatic control of the processes occurring within the system must also be possible.

### III. PROPOSED METHODOLOGY

#### A. System Overview

The suggested model is an intelligent hydroponics cultivation method that utilizes IoT-based sensing and automation through the ESP32 microcontroller. The design aims to monitor all vital parameters and automate the system's functionalities for maximum plant growth potential.

#### B. System Components

The hardware system comprises:

- ESP32 Microcontroller – Control module
- DHT22 Sensor – Temperature and Humidity measurement
- pH Sensor – pH level detection of nutrient solution
- TDS Sensor – Nutrient level measurement
- Water Level Sensor – Detection of the nutrient solution level
- Relay Module – Electrical device control
- Water Pump – Automatic replenishment of the nutrient solution
- Blynk IoT Platform – Provides remote monitoring

#### C. System Architecture

The system is divided into three layers:

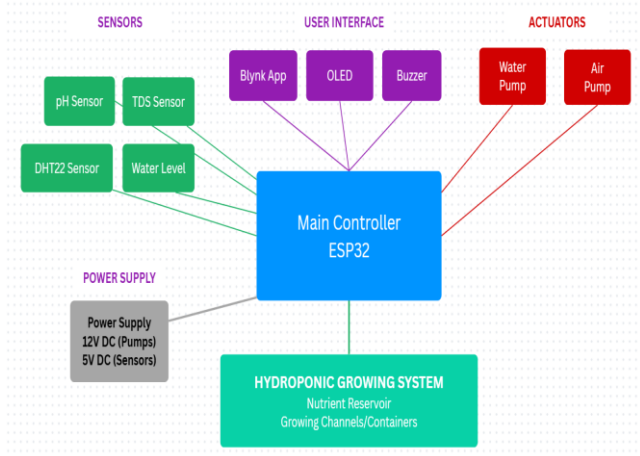

Fig. 1. Block diagram of proposed hydroponic system

Fig. 1 displays the block diagram of the suggested hydroponics system. In this system, the ESP32 is used as a controller, where all information about the system is sensed by the pH, TDS, DHT22, and water level sensors. Depending upon the information received by the sensors, the actuator, including the water pump, is controlled. The IoT technology, Blynk, is used to monitor the system via Wi-Fi communication.

1. **Sensing Layer**  
Collects real-time data using sensors
2. **Processing Layer**  
ESP32 processes data and compares with threshold values
3. **Application Layer**  
Blynk IoT displays data and provides alerts

#### D. Working Principle

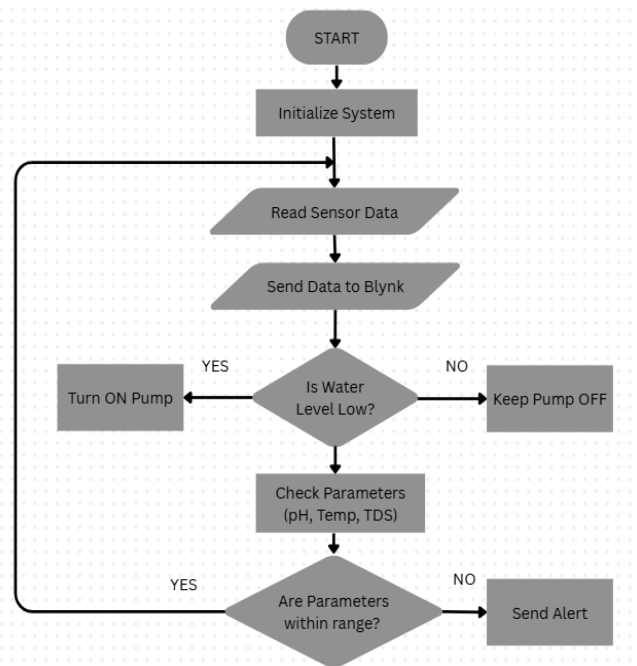

Fig. 2. Flowchart of proposed hydroponic system

Fig. 2 demonstrates the operational process of the suggested hydroponics system. The ESP32 module starts and calibrates all the sensors and constantly monitors factors like temperature, humidity, pH, TDS, and water level. This data is sent to the Blynk IoT application for real-time monitoring purposes. In case when water level goes below the threshold value, the water pump starts automatically; otherwise, it stays switched off. The system also verifies whether the environmental parameters fall within the required limits or not and generates alerts if there are abnormal values. The system operates in a continuous feedback loop as shown in Fig. 2.

- Sensors collect real-time data
- ESP32 processes and evaluates data
- If parameters deviate from optimal range, corrective actions are triggered

#### Automatic Water Level Control

- Water level sensor detects low nutrient level
- ESP32 activates pump via relay
- Tank is refilled automatically
- Pump stops when optimal level is reached

This ensures uninterrupted nutrient supply and stable plant growth conditions.

#### E. IoT Integration

The system employs the Blynk IoT platform for real-time monitoring and control. The application shows the following: Temperature and Humidity, pH Value, TDS Value, Water Level Status. Users can monitor the system remotely and receive notifications whenever any parameter goes beyond its safety limit.

#### F. Advantages of Proposed System

- Fully automated system with minimal human intervention
- Real-time monitoring using IoT
- Automatic water level maintenance
- Cost-effective and easy to implement
- Suitable for small-scale and urban farming

### IV. IMPLEMENTATION

#### A. Hardware Implementation

The hardware configuration of the system uses the ESP32 microcontroller as the core component for processing data and communicating information. Different sensors are connected to the ESP32 microcontroller in order to acquire data about the environment and nutrient solutions.

The DHT22 sensor helps to measure the temperature and humidity of the environment, while the pH sensor calculates the acidity levels of the nutrient solutions. The TDS sensor is responsible for calculating the quantity of nutrients in the water. Moreover, a water level sensor is placed in the nutrient solution tank in order to monitor its level continuously.

The operation of the water pump is based on the relay, which takes input commands from the ESP32 microcontroller. In case the water quantity becomes less than the specified one, the ESP32 microcontroller will switch the relay ON to start the water pump. After the water rises up to the desired level, the microcontroller will turn OFF the pump.

#### B. Software Implementation

Software development of the project is carried out in the Arduino environment, which programs the ESP32 board in order to collect and process the data collected by sensors and controlling the operation of system elements.

The program collects data from all sensors installed in the system and compares their values with the set threshold values. With the help of conditional statements, it becomes possible to perform certain actions based on this comparison.

Wi-Fi capabilities of the ESP32 are employed to transfer sensor data to the Blynk IoT platform. This transfer can be made due to the employment of Blynk libraries that facilitate this process.

#### C. IoT Dashboard (Blynk Integration)

The Blynk IoT platform is employed to develop a dashboard application based on the mobile phone, through which real-time monitoring of the hydroponic system will take place.

The dashboard will include:

- Temperature
- Humidity
- pH value
- TDS value
- Status of water level

Each of the above-listed parameters will be connected to the respective virtual pin in the Blynk app. This will enable the user to get continuous feedback and notifications.

#### D. System Operation

The whole process takes place in a continuous loop where:

1. Data is gathered by the sensors in real time
2. The ESP32 analyzes the gathered data
3. The analyzed values are sent to the Blynk app
4. The collected values are checked for compliance with the thresholds set
5. In case of water shortage: The pump is started automatically
6. Once everything returns to normal: The pump is shut off.

This ensures continuous monitoring and automatic control without manual intervention.

#### E. Implementation Outcome

Real time monitoring and automation of the hydroponic parameters have been successfully demonstrated by the developed system. This combination of sensors, ESP32, and Blynk offers an effective and efficient solution for smart farming. The ability to monitor the water level automatically ensures that nutrients can be supplied without interruption, which leads to better plant growth.

#### F. Simulation

Since there is no support available for ESP32 in the Proteus simulation software, Arduino Uno was chosen as a suitable replacement for this purpose. The simulation was performed to confirm the interface of the sensors, control mechanism, and actuators. The functionality of the system using Arduino Uno helped to ensure that all system logic was functioning properly before implementing it practically using ESP32.

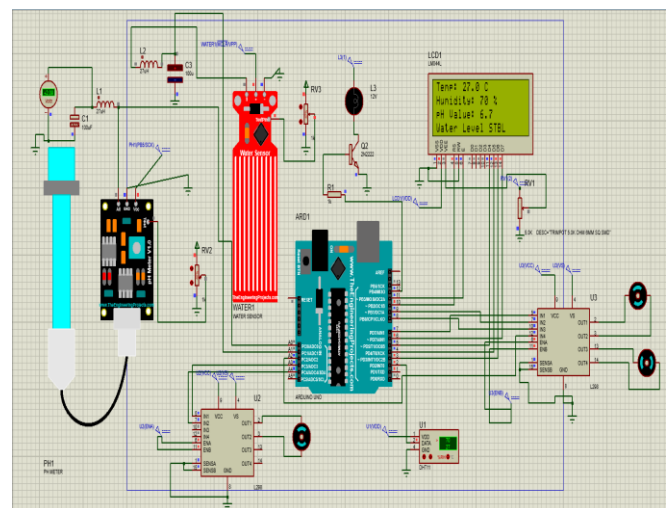

Fig. 3. Proteus Simulation of Hydroponic Monitoring and Control System

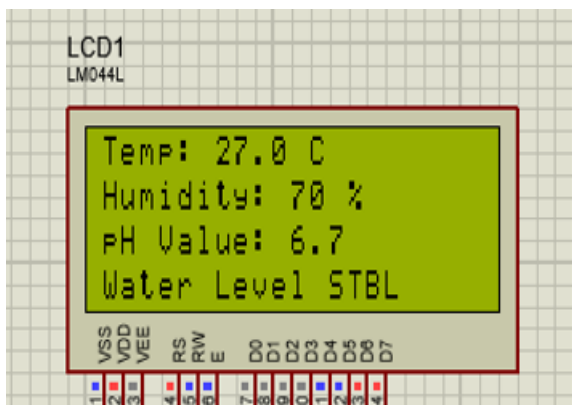

Fig. 4. LCD output showing sensor parameters

The total simulation of the hydroponic system using Proteus is shown in Fig. 3, while the output of the LCD display during the simulation run is shown in Fig. 4.

This figure clearly shows real-time values of the temperature, humidity, pH, and the water level status. It can be concluded from the results of simulation that the proposed hydroponic system is able to respond according to various inputs, making sure of correct automation and control before going live.

## V. RESULTS AND DISCUSSIONS

### A. System Performance

The proposed hydroponics system underwent controlled testing to determine its ability to control plant growth through parameter measurement and optimization. The system proved successful in recording data in real time from all sensors such as temperature, humidity, pH, TDS, and water level readings.

In addition, the stability and consistency of the system were established, with successful data transmission from ESP32 sensors to Blynk IoT. Real-time monitoring enabled remote monitoring of the system without any delay in receiving data.

Table I  
 Optimal Growth Conditions for Hydroponic Plants

Parameter	Ideal Range	Observed Range
Temperature(°C)	18-25	23-28
Humidity	50-70	58-66
pH Level	5.5-6.5	6.2-6.6
TDS(ppm)	500-1000	600-950

Table I shows the ideal environmental conditions as well as nutrient requirements for various hydroponics crops. Given that the designed system creates a standard environment for all plants, general parameter analysis was done rather than varying the parameters for each individual plant. All the recorded figures are within acceptable limits.

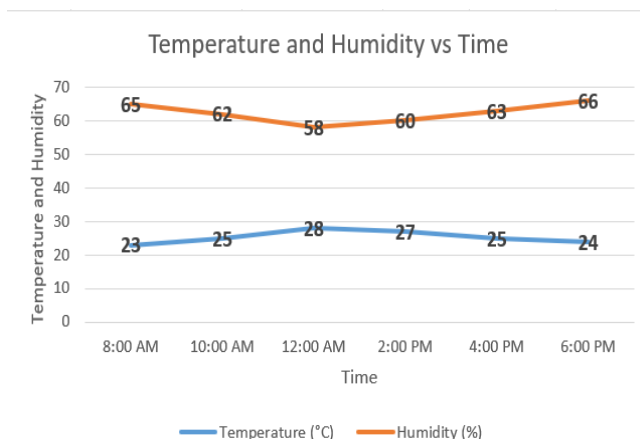

Fig. 5. Temperature and humidity variation over time

The graph represents the fluctuations in the values of temperature and humidity over time. The highest point in temperature is reached at noon and then falls gradually to the evening hours, whereas humidity follows an opposite pattern.

### B. Sensor Observation

The results generated by the sensors were very reliable and accurate during the entire test period:  
 Temperature and Humidity: Controlled at an ideal level for plant cultivation  
 pH value: Continuously monitored for better nutrient uptake  
 TDS value: Used to control the nutrient concentration  
 Water level: Detected accurately and corrected on time  
 These results indicate that the sensor system is able to successfully monitor all necessary hydroponic parameters.

### C. Automation Results

The automatic water level control is among the main features of the system. The water level sensor was able to detect low levels of nutrients, and ESP32 triggered the operation of the pump.

- Triggered the pump when there were low levels of water
- Stopped the operation of the pump when the optimum level was reached

The automatic system made sure that nutrients were always available without having to intervene manually.

### D. Discussion

From the above results, the combination of IoT and automation has been proven to improve the efficiency of hydroponics. The proposed system has fewer human interactions, accurate data monitoring capabilities, effective use of resources, and increased efficiency. Automatic regulation of water level is an aspect that solves one of the shortcomings that exists in other systems. As a whole, the system provides evidence of smart hydroponics as a sustainable solution to agriculture.

## VI. CONCLUSION AND FUTURE WORK

### A. Conclusion

The purpose of this paper is to introduce the design and implementation of a smart hydroponic farming system that employs an ESP32 microcontroller embedded with IoT technology. This system supports the real-time monitoring of important variables such as temperature, humidity, pH value, TDS, and water level. The incorporation of various sensors helps ensure the precision in data collection, thus ensuring the proper management of optimal conditions required for healthy plant development.

Additionally, automatic control of the water level through sensors and pumps has been achieved, significantly minimizing labor costs while maintaining an adequate supply of nutrients. Finally, Blynk IoT platform has been implemented as an easy-to-use interface for real-time monitoring purposes.

From the experimental findings obtained from this study, it can be noted that this method proves efficient, environmentally friendly, reliable, and economically feasible when compared to traditional methods of hydroponic farming.

### B. Future Work

While the system is functioning efficiently, there are several areas that can be improved to make it more effective and scalable. Machine learning models can be implemented to make accurate predictions about crop development and help manage nutrients according to their needs. Light intensity sensors, together with automatic lighting control systems, can increase the quality of crops grown by maintaining proper environmental conditions.

Monitoring with the use of cameras is another feature that can be added to detect diseases and plant health issues. Besides, the implementation of cloud computing technology will help collect valuable data about the system's performance and facilitate decision-making.

The suggested system can also be scaled to apply in large-scale hydroponics production facilities. Moreover, renewable energy sources, such as solar power, can be integrated to enhance sustainability and decrease operating costs.

## REFERENCES

- [1] J. C. Joshitha, N. Bawgi, B. P. Ranga, and B. Harshini Reddy, "A Sensor-Driven Automated Hydroponic System for Optimized Plant Growth in Diverse Environments," in *Proceedings of IEEE*, 2025, pp. 1–7.
- [2] E. Blancaflor, J. N. D. Jamena, K. N. U. Baganay, R. S. C. Rabanal, K. E. Fernandez, and S. L. G. Zamora, "An IoT Monitoring System Designed for Hydroponics Plant Cultivation," *Mapua University Research Publication*, Makati, Philippines, 2023.
- [3] K. Ezhilarasan, S. A. N., and N. Sridhar, "Automated Hydroponic Vertical Farming using IoT," in *3rd IEEE International Conference on Knowledge Engineering and Communication Systems (ICKECS)*, India, 2025, pp. 1–8.
- [4] G. Brindha, D. Devadharshini, T. Kumaragurubaran, and S. Dhanush, "Automating Hydroponics: Enhance the Crop Cultivation and Monitoring Using IoT and ML," *International Journal / Conference Publication*, 2024.
- [5] P. Gourshettiwar and K. T. V. Reddy, "Development of an IoT-Enabled Real-Time Monitoring and Alert System Model for Hydroponic Farming," in *International Conference on Trends in Material Science and Inventive Materials (ICTMIM)*, India, 2025.
- [6] C. Suresh and S. Selvabhuvaneswari, "Enhancing Hydroponic Farming using IoT Integration and Machine Learning Techniques," *Journal / Conference Publication*, Tamil Nadu, India, 2024.
- [7] A. B. Varghese and D. M. P., "Enhancing Hydroponic Production: A Review of Plant Growth and Health Monitoring System," in *International Conference on Intelligent Cyber Physical Systems and IoT (ICoICI)*, India, 2024, pp. 492–498.
- [8] S. Debdas, A. Jain, A. Mariam, A. Maiti, and A. Borah, "Enhancing Hydroponic Systems with IoT: Optimizing pH, Temperature, and Humidity Parameters," in *IEEE Odisha International Conference (ODICON)*, India, 2024.
- [9] S. P. R. M., V. V., R. S., and R. A. N., "IoT Integrated Hydroponic System for Precision Agriculture," *RMD Engineering College Research Publication*, India, 2024.
- [10] V. Waghmare, P. Rakte, M. Gadalkar, S. Bhaleghare, D. Sakhare, and M. Goudar, "Real Time Monitoring of Hydroponic System using IoT," *MIT Academy of Engineering Publication*, Pune, India, 2024.
- [11] P. S. Prakash, S. A. Jabeen, L. Venkat, Y. Sagar, and M. Ismail, "Smart Hydroponic System: An AI and IoT-Powered Fertilizer and Plant Health Monitoring Solution for Sustainable Plant Growth," in *IEEE International Conference on Pervasive Computing and Social Networking (ICPCSN)*, India, 2025.
- [12] G. Gokulraj, K. M. Kirthika, R. N. Devendra Kumar, B. Vadivel, M. Suresh Kumar, and V. Padmasharan, "Smart IoT Based Nutrition Alert System for Hydroponic Plant Growth," in *International Conference on Trends in Material Science and Inventive Materials (ICTMIM)*, India, 2025.
- [13] U. Krishnan, A. Dutt, J. Singh, M. Bhavana, S. Baswaraju, B. F. Mohammed, and A. Venkatraman, "Urban Vertical Farming with IoT and Precision Monitoring for a Sustainable Future," in *IEEE International Conference on Intelligent Control, Computing and Communications (IC3)*, 2025.
- [14] N. Chumuang, "Vertical Farming with Smart Technology to Increase Agricultural Productivity," in *IEEE Conference Proceedings*, 2025.