

# Surge Protection on Power Line for Typical Telecommunication Sites in Vietnam

Quyen Huy Anh, and Le Quang Trung  
Ho Chi Minh City University of Technology and Education  
Viet Nam

**Abstract** - This article presents the calculating of the risk of damage due to lightning for the telecommunication site (TS); this procedure consists of nine steps to determine the value of the risk of loss of human life ( $R_1$ ) and the risk of loss of service ( $R_2$ ). When these values are greater than the tolerable risk values  $R_{T1}$  and  $R_{T2}$  respectively, it is important to choose the lightning protection measure appropriate to the characteristics of the structure should be selected. In addition, the selection procedure for the surge protective device on the power line includes six steps that meet technical requirements is also considered. The proposed calculation procedures are illustrated for a typical TS.

**Keywords:** Risk of damage due to lightning; lightning protection; surge protective device; telecommunication sites.

## I. INTRODUCTION

Over the past few years, a number of studies have been conducted to assess the risk of damages due to lightning to buildings [1-4] and telecommunication sites (TSs) [5]. Z.janklovics also research on the place and role of the power supply in the overvoltage protection and risk assessment of damages to TSs due to lightning. The research results show that a part of the risk of damages due to lightning is predicted to be caused by power supply lines [6]. In addition, the study of the factors influencing the selection and installation of surge protective devices (SPD) for low voltage systems, the selection of SPD to meet the level of lightning protection influenced by the length and the characteristics of the connection circuit between the SPD and the protected device are also presented in [7]. The above mentioned researchs are discrete and do not propose the total solution of surge protection on power line for structure from the risk assessment to propose solutions for selection and installation SPD to ensure the technical to reduce the risk of damage caused by lightning to the application of simulation model to test the response ability of SPD on power line.

This paper presents the procedure of calculation and selection of the surge protective devices for a typical TS and based on the results of research that applied to calculate and select the surge protective devices on the power line for a typical TS in Long Thanh district, Dong Nai province, Vietnam. In particular, the value of the risk of human life ( $R_1$ ) and the value of risk of loss of services ( $R_2$ ) will be calculated. When these values are greater than the tolerable risk values  $R_{T1}$  and  $R_{T2}$  respectively, it is important to choose the lightning protection measure appropriate to the characteristics of the structure so that the risk values  $R_1$  and  $R_2$  are less than the tolerable risk values ( $R_{T1}$ ,  $R_{T2}$ ) [8-10]. Afterward, the power distribution network model of the structure is built on

the Matlab, the selection of lightning protective devices on the power line, the installation of these devices in reasonable locations and the simulation of the protective performance of the devices are carried out. As a result, it is possible to select the protective devices to meet the actual requirements of the structure with reasonable investment costs.

## II. STEPS OF CALCULATION AND SELECTION OF SURGE PROTECTOR ON THE POWER LINE

### 1. Risk assessment steps for a typical telecommunication site

The procedure of risk assessment for typical structure consists of 9 steps and shown in Figure 1.

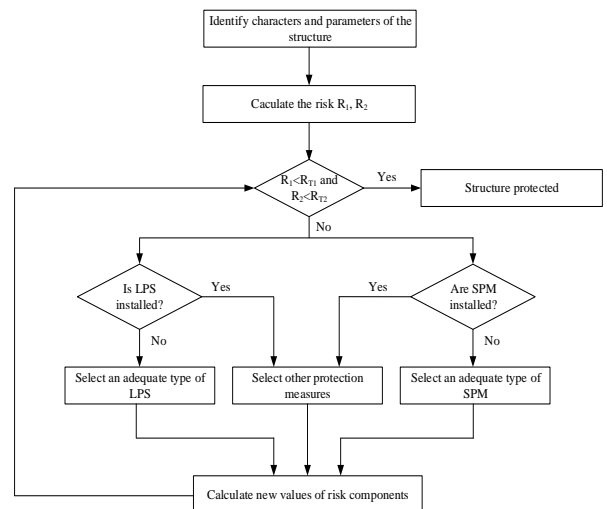

Note:  $R_1$ ,  $R_2$  are respectively the value of risk of loss of human life and the value of risk of loss of service;  $R_T$  is the tolerable risk value; Lightning Protection System (LPS); Surge Protection Measures (SPM).

Figure 1. Risk assessment steps for typical telecommunication site.

The risk assessment procedure for Telecommunication Site (TS) consists of 9 steps as follows:

- Step 1: Identify the characteristics and parameters of TS to be protected against lightning: structure dimensions; height of adjacent antenna tower; level of shielding by other structure nearby; lightning density; fire protection measures; the number, installation method and length of the service line connected to the structure; existing lightning protection measures, etc.

- Step 2: Calculate the risk components for a structure due to direct and indirect lightning strike. From there, calculate the risk of loss of human life and the risk of loss of service by the method presented in [8-10] for the structure.
- Step 3: After calculating the risk values R1 and R2, compare the values R1 and R2 with the risk values for RT1 and RT2 as proposed by IEC 62305-2 [1]. If the risk values R1 and R2 are greater than the tolerable risk values RT1 and RT2, Step 4 and Step 5 will be continued, if the risk values R1 and R2 are less than tolerable risk values RT1 and RT2, the structure is protected, the simulation of protective performance of the surge protective devices (SPDs) on the power line are carried out according to the procedure as in Section B.
- Step 4: Consider whether the structure is equipped with LPS or not? Move to Step 8 if the structure is equipped with LPS. Move to Step 6 if the structure is not equipped with LPS.
- Step 5: Considering whether the structure is equipped with SPM on the power line or not? Move to Step 7 if the structure is not equipped with SPM. Move to Step 8 if the project is equipped with SPM.
- Step 6: Select and equip the structure with the appropriate LPS system.
- Step 7: Select and equip the power line with an appropriate SPM system.
- Step 8: If the structure has been equipped with LPS and SPM but the risk of loss due to lightning R1 and R2 is still greater than the tolerable risk values. Additional protection measures should be taken such as increased level of LPS, increased level of protection and/or the number of surge protective device (SPD).
- Step 9: Recalculate the new risk values and return to Step 3.

2. The selection steps for SPD

After assessing the risk due to lightning, the selection steps of SPDs consists of 6 steps and shown in Figure 2.

The procedure of selection and testing the protection of SPD on the power line consists of 6 steps as follows:

- Step 1: Based on the single line diagram of the power line for the structure, the model of electricity distribution network will be built on the simulation software.
- Step 2: Select the SPD on the power line as built in [11] appropriate to the load to be protected.
- Step 3: Select the location of the SPD on the power line: Main distribution panel; sub-distribution panel, at the feed of load.
- Step 4: Simulate the response of the SPD on the power line with the surge generator model as built in [11] by

generating surge propagation at different positions on the power line according to the corresponding protection zone as shown in Figure 3 [12] and the intensity of the surge current according to the lightning density and the corresponding protection area in Table 1 [13] and the protection voltage at the terminal of the device in each case.

- Step 5: Check the protection voltage  $U_P$ : According to IEC 61643-1 [14] for electrical equipment, protection voltage:

$$U_P \leq (1200 + U_n) \tag{1}$$

- Step 6: Conclusion of the structure has been protected from the risks of surge on the power line.

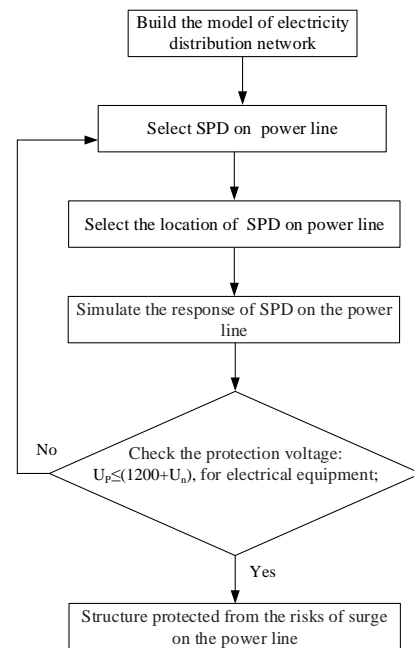

Note: with  $U_P$  is protection voltage of the device;  $U_n$  is the nominal voltage of the system.

Figure 2. Selection steps of SPD on the power line.

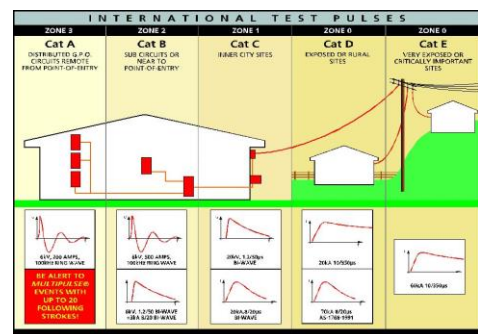

Figure 3. Surge current waves according to the recent international standards.

Table 1. Surge current values, according to the protection category and the lightning density

Ng (strikes/km <sup>2</sup> /year)	Cat A	Cat B	Cat C	Cat D	Cat E
>2	10kA	20kA	40kA	70kA	100kA
0.5÷2	5kA	20kA	20kA	40kA	65kA
<0.5	3kA	5kA	15kA	40kA	65kA

### III. CALCULATION FOR TYPICAL STRUCTURE

#### A. Characteristics of typical TS

A typical structure is a TS in Long Thanh district, Dong Nai province, Vietnam, built in reinforced concrete, the lightning density of the area is 13.7 strikes/km<sup>2</sup>/year [15] and no other higher structure nearby. The antenna tower is built in steel, 4m from the station and has a height of 50m.

- The length of the power line and telecom lines connected to the station are 500m and 1000m, respectively.

- The lightning protection system has been installed and the telecom lines have been installed with SPM.

- The power line is not installed with SPM.

- The TS should be assessed for the risk of loss of human life and the risk of loss of service due to lightning to select SPD on the power line.

#### B. Assess the risk of damage due to lightning for the telecommunication site

- Step 1: Identify the characteristics and parameters of structure to be protected.
- Step 2: Calculate the risk values due to lightning  $R_1$  and  $R_2$ :

The calculated results are presented in Table 2 and Table 3.

Table 2. Risk values before installation of SPD

Calculated risk values	The tolerable risk values	Comparison results
$R_1 = 3.88 \times 10^{-6}$	$R_{T1} = 10^{-5}$	$R_1 < R_{T1}$
$R_2 = 0.054$	$R_{T2} = 10^{-3}$	$R_2 > R_{T2}$

From Table 2, realize that the value of risk  $R_2$  is higher than the tolerable risk value.

- Step 4: Consider whether the structure is equipped with LPS or not?

The structure was installed with LPS class I.

- Step 5: Considering whether the structure is equipped with SPM on the power line or not?

The structure is not installed with SPM on the power line.

- Step 7: Select and equip the power line with an appropriate SPM system:

Select the lightning protection level (LPL) with class I.

- Step 9: Recalculate the new risk component values and risk value  $R_2$ , the result is shown in Table 3.

Table 3. Risk values after installation of the SPD.

Calculated risk values	The tolerable risk values	Comparison results
$R_1 = 6.64 \times 10^{-8}$	$R_{T1} = 10^{-5}$	$R_1 < R_{T1}$
$R_2 = 0.00022$	$R_{T2} = 10^{-3}$	$R_2 < R_{T2}$

Comment: Risk values  $R_1$  and  $R_2$  are less than tolerable risk values  $R_{T1}$  and  $R_{T2}$  respectively. Therefore, on the basis of the theoretical calculation of the risk, the structure has been protected from the risk of damage due to lightning, continue to test the protection performance of SPD on the power line.

#### C. Select and test the protection performance of SPD on the power line

- Step 1: Building a distribution network model on simulation software.

Based on the single line diagram of the power line for the TS, the devices are in the station, building the distribution network model on the Matlab as shown in Figure 4.

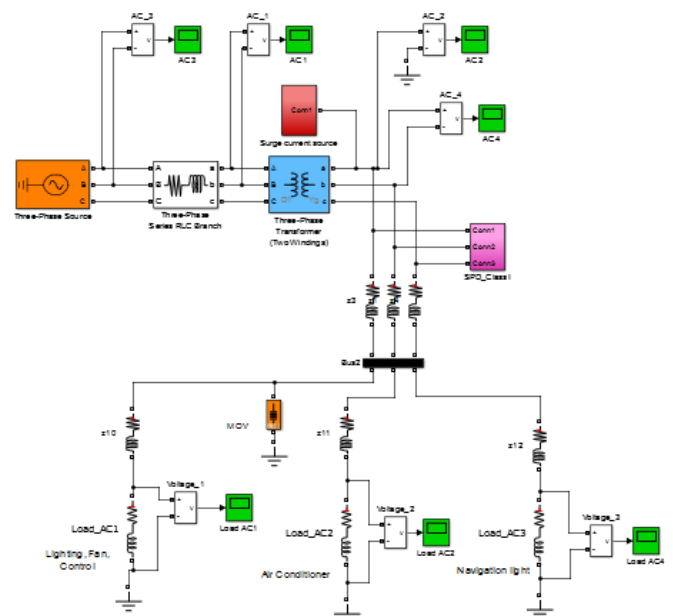

Figure 4. Power distribution network simulation diagram in Matlab.

- Step 2: Select the SPD on the power line:

At the essential main switchboard (EMSB), select SPD class I with the rated voltage of 275V, rated current of 40 kA or 70 kA.

At the main switchboard (MSB), select SPD class II with the rated voltage of 275V, rated current of 25 kA or 40 kA.

- Step 3: Select the location of the SPD on the power line:

Choose the location of SPD on the power line at EMSB and the MSB.

- Step 4: Simulate the response of the SPD on the power line and inspect the protection voltage of the load:

Due to the lightning density of the area is 13.7 strikes/km<sup>2</sup>/year as shown in Figure 3 and Table 1, simulated

with surge current  $8/20\mu\text{s}$  40kA, when SPD has not been installed.

The protection voltage simulation values at the loads are shown in Table 4, the protection voltage waveform shown in Figure 5.

Table 4. The protection voltage simulation values at loads, without SPD

Rated current amplitude $8/20\mu\text{s}$ (kA)	The peak of protection voltage across the loads (V)
40	38600

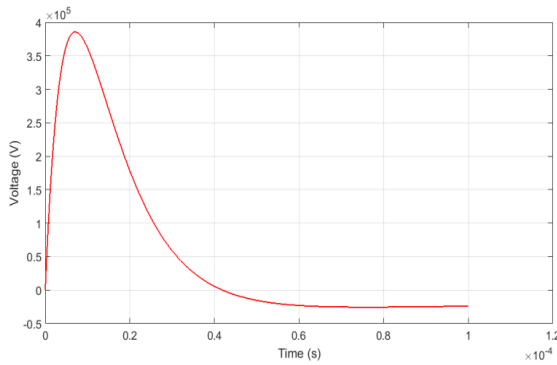

Figure 5. Protection voltage waveform across the load when SPD is not installed.

- Step 5: Checking the protection voltage:

From the simulation results in Table 4, realize that: For electrical equipment with rated voltage is 230V:  $U_P=38600V \geq (1200V + 230V) = 1430V$ .

The protection voltage values across the loads are greater than the tolerable protection voltage as specified by the standard. Therefore, it is necessary to install the SPD to protect electronic devices against surge on the power line.

- Back to step 2: Select SPD class I to install at the EMSB with the rated voltage of 275V, rated current is 40kA, 70kA or 100kA; SPD class II to install at the MSB with rated voltage of 275V, rated current is 25kA, 40kA or 70kA.
- Step 3: Select the location of the SPD on the power line:

Choose the location of SPD on the power line at the EMSB and the MSB.

- Step 4: Simulate the response of the SPD on the power line and inspect the protection voltage of the load:

Simulate with surge current  $8/20\mu\text{s}$  40kA with SPD installed, the protection voltage simulation values at the load is shown in Table 5, the protection voltage waveform across the loads as shown in Figure 6.

Table 5. The protection voltage simulation values for loads when SPDs are installed in the essential main switchboard and main switchboard.

Rated current amplitude $8/20\mu\text{s}$ (kA)	Voltage tolerance of MOV (%)	SPD class I			SPD class II		
		Rated voltage of MOV (V)	Rated current of MOV (kA)	The peak of protection voltage across the load (V)	Rated voltage of MOV (V)	Rated current of MOV (kA)	The peak of protection voltage across the loads (V)
40	10	275	40	1775	275	25	1118
						40	1070
40	10	275	70	1660	275	25	1089
						40	1061
						70	1011
40	10	275	100	1410	275	25	1008
						40	976
						70	949

Comment: The simulation result in Table 5 shows that the highest protection voltage value is 1117V when installing SPD class I 40kA, 275V and SPD class II 25kA, 275V; the lowest protection voltage value is 950V when installing SPD class I 100kA, 275V and SPD class II 70kA, 275V. It can be seen that the rated current of the SPDs class I is 2.5 times higher and the rated current of the SPDs class II is 2.8 times higher while the protection voltage across the load just decreases by 1.17 times. Therefore, installing SPD class I 40kA, 275V and SPD class II 25kA, 275V will still ensure the effective protection for loads with the lowest investment cost.

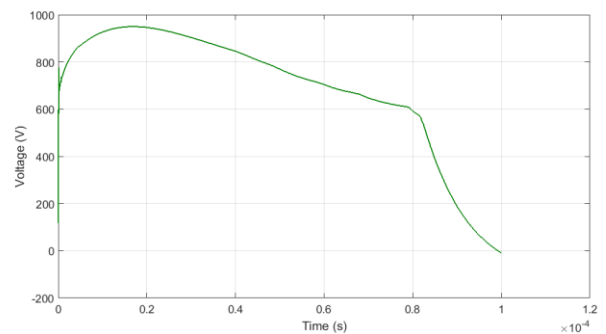

Figure 6. Protection voltage waveform at load when surge current  $8/20\mu\text{s}$  40kA propagates on the power line after the transformer goes into the SMSB, with the SPD 275V-100kA installed in the EMSB and the SPD 275V- 70kA in the MSB.

- Step 5: Voltage protection test: From table 5, it can be seen that for electrical equipment, protection voltage values  $U_P$  across the load with SPD class I installed at the EMSB and SPD class II installed at the MSB are less than 1430V.

Select SPD class I and class II with rated voltage is 275V and rated currents are 40kA and 25kA, respectively.

- Step 6: Conclusion of the structure has been protected from the surge on the power line.

#### IV. CONCLUSION

The paper proposes a total solution of surge protection on the power line for TS following the steps: Determining the risk of damage due to lightning by analytical methods and applying simulation modeling to select the parameters and location of SPD on the power line to meet the technical

requirements. The effectiveness of the proposed solution has been applied to a typical TS in Long Thanh District, Dong Nai Province, Vietnam, with the following results:

- When the surge protection has not been applied, the structure has the risk of loss of service value  $R_2 = 0.054$  which is higher than the tolerable risk value. When SPD class II is installed, the  $R_2$  value is 0.00022 and it is lower than the tolerable risk value;
- Simulated results show that in order to achieve the protective effect on demand, SPD class I 40kA, 275V at EMSB and SPD class II 25kA, 275V at MSB should be installed. The protection voltage at the test locations is lower than the tolerable voltage specified in IEC 6143-1.

#### ACKNOWLEDGMENT

This research was supported by Ho Chi Minh City University of Technology and Education under a research at the Electrical Power System and Renewable Lab.

#### REFERENCES

- [1] IEC 62305-2, Ed. 2,0 2010-12, "Protection Against Lightning – Part 2: Risk management".
- [2] Australian/New Zealand Standard, "Lightning protection", 2007
- [3] G. B. Lo Piparo, A. Kern, C. Mazzetti, "Some Masterpoints about Risk due to Lightning", *International Conference on Lightning Protection (ICLP)*, Vienna, Austria, 2012
- [4] Riyadh W. Y. Habash, Voicu Groza, "Lightning Risk Assessment of Power Systems", *IEEE Electrical Power & Energy Conference*, 2010
- [5] ITU-T Recommendation K.39, "Risk assessment of damages to telecommunication sites due to lightning discharges", 1996
- [6] Z. Janklovics, "The place and role of power supply in the overvoltage protection and risk assessment of damages to telecommunication sites due to lightning discharges", *Telecommunications Development Institute*.
- [7] T. Kisielewicz, F. Fiamingo, Z. Flisowski, B. Kuca G.B. Lo Piparo C. Mazzetti, "Factors Influencing the Selection and Installation of Surge Protective Devices for Low Voltage Systems", *IEEE*, 2012.
- [8] Quyen Huy Anh, Le Quang Trung, Phan Chi Thach, "Compare Different Recent Methods and Propose Improved Method for Risk Assessment of Damages Due to Lightning", *The 2<sup>nd</sup> AETA 2015*, Ton Duc Thang University, Ho Chi Minh City, Vietnam, December 2015.
- [9] Le Quang Trung, Quyen Huy Anh, Phan Chi Thach, "Risk assessment of damage to telecommunication sites due to lightning in typical areas in Vietnam by the improved method", *International Journal of Engineering Research & Technology (IJERT)*, ISSN: 2278-0181, Vol. 4 Issue 08, August-2015.
- [10] Le Quang Trung, Quyen Huy Anh, Phan Chi Thach, "Risk assessment of damage to television and radio station due to lightning", *Journal of Science and Technology Technical Universities*, ISSN 2354- 1083, No.114, 2016.
- [11] Le Quang Trung, Quyen Huy Anh, Dinh Thi Ngoan, "Building the surge generator model and the multi layervaristor model according to the international standards", *Journal of Technology Education Science*, Ho Chi Minh City of University of Technology and Education, No.41, 2017.
- [12] Quyen Huy Anh, Le Quang Trung, "Selection guide for low voltage surge protector", *International Journal of Engineering Research & Technology (IJERT)*, ISSN: 2278-0181, Vol. 6 Issue 10, October - 2017.
- [13] Quyen Huy Anh, "Electrical safety", *Vietnam National University Publishing House - Ho Chi Minh City*, Vietnam, 2012.
- [14] IEC 61643-1, Ed. 1.1, "Performance requirement and testing methods", 2012.
- [15] QCXDVN 02 : 2008/BXD, Vietnam Building Code Natural Physical & Climatic Data for Construction (Part 1), 2008.