

Supervision of DC link PI control in a D-STATCOM based Fuzzy Logic

P.Ramanjaneyulu,
PG Student,
SVP CET,
Puttur,Chittoor(Dist)

T.Varaprasad,
Assistant Professor,
SVP CET,
Puttur,Chittoor(Dist)

Abstract : A DSTATCOM, which is one of the custom power devices, is used to control the terminal voltage. In a DSTATCOM, generally, the dc capacitor voltage is regulated using a PI controller when various control algorithms are used for load compensation. However, during load changes, there is considerable variation in dc capacitor voltage which might affect compensation. In this work, a fuzzy logic based supervisory method is proposed to improve transient performance of the dc link. The fuzzy logic based supervisor varies the proportional and integral gains of the PI controller during the transient period immediately after a load change. An improvement in the performance of the controller is obtained because of appropriate variation of PI gains using expert knowledge of system behavior and higher sampling during the transient period. A 50% reduction in the error in dc link capacitor voltage during load change compared to a normal PI controller is obtained. The voltage waveform also has a faster settling time. The efficacy of the proposed strategy is proved using detailed MATLAB simulation studies.

1.INTRODUCTION

The concept of Flexible Ac Transmission (FACTS), as the name implies, was originally developed for transmission networks but similar ideas are applied to distribution systems. The new high power electronic systems applied to Distribution systems owe something to the ideas of FACTS but also use concepts and techniques

developed for power electronic systems with lower voltage and current ratings.

POWERQUALITY ISSUES AND SOLUTIONS IN DISTRIBUTION SYSTEMS

2.1 Introduction

FACTS use the latest power electronic devices and methods to control electronically the high-voltage side of the network.

A Custom Power specification may include provision for

1. No power interruption.
2. Tight voltage regulation including short duration sags or swells
3. Low harmonic voltages
4. Acceptance of fluctuating and non linear loads without effect on terminal voltage.

3.DSTATCOM

3.1 Operating Principle Of DSTATCOM:

Basically, the DSTATCOM system is comprised of three main parts: a VSC, a set of coupling reactors and a controller. The basic principle of a DSTATCOM installed in a power system is the generation of a controllable ac voltage source by a voltage source inverter (VSI) connected to a dc capacitor (energy storage device). The ac voltage source, in general, appears behind a transformer leakage reactance.

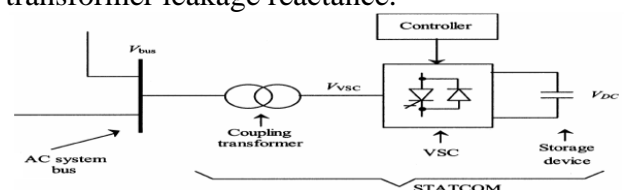

Fig.1. Block Diagram of the voltage source converter based DSTATCOM

3.2.1 Voltage Regulation without Compensator:

Consider a simple circuit as shown in Fig 3.2. It consists of a source Voltage E , V is the voltage at a PCC and a load drawing the current I_l. Without a voltage compensator, the PCC voltage drop caused by the load current I_l, shown in fig as ΔV,

$$\Delta V = E - V = Z_s * I_l,$$

$$S = VI^* \text{ ,so } S^* = V^* I$$

From above equation,

$$I_l = \frac{P_l - j * Q_l}{V}$$

so that,

$$\Delta V = (R_s + jX_s) \left(\frac{P_l - jQ_l}{V} \right)$$

$$= \frac{(R_s P_l - X_s Q_l)}{V} + j \frac{(X_s P_l + R_s Q_l)}{V}$$

$$= \Delta V_r + \Delta V_x$$

The voltage change has a component ΔV_R in phase with V and component ΔV_x, which are illustrated in Fig 3.2(a). It is clear that both magnitude and the phase of V, relative to the supply voltage E, are functions of the magnitude and phase of the load current namely the voltage drop depends on both the real and reactive power of the load. The component ΔV is rewritten as

$$\Delta V = I_s R_s + j I_s X_s$$

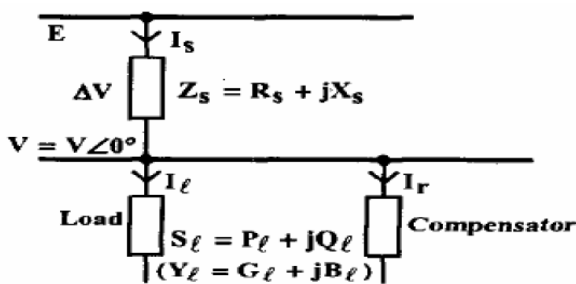

Fig. 2 A Simple Circuit for demonstrating the voltage regulation principle.

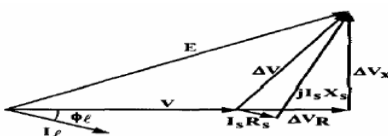

Fig. 3 Phasor diagram for uncompensated

3.2.2 Voltage Regulation With DSTATCOM:

Now consider a compensator connected to the system. It is as shown in Fig 3.2(b) shows vector diagram with voltage compensation. By adding a compensator in parallel with the load, it is possible to make 1/2 E 1/2 = 1/2 V 1/2 by controlling the current of the compensator.

$$I_s = I_r + I_l$$

Where I_r is the compensating current

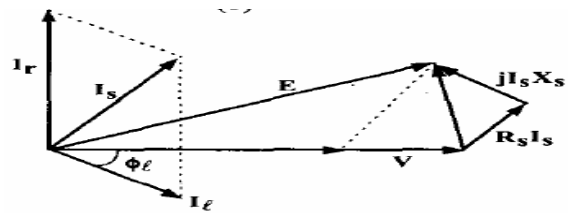

Fig. 4 Phasor diagram for voltage regulation with compensation

3.3 DSTATCOM Voltage Regulation Technique

The DSTATCOM improves the voltage sags and swell conditions and the ac output voltage at the customer points is improved, thus improving the quality of power at the distribution side. In this thesis the voltage controller technique (also called as decouple technique) is used as the control technique for DSTATCOM. In this VABC are the three-phase terminal voltages, I_{abc} are the three-phase currents injected by the DSTATCOM into the network, V_{rms} is the root-mean-square (rms) terminal voltage, V_{dc} is the dc voltage measured in the capacitor, and the superscripts indicate reference values.

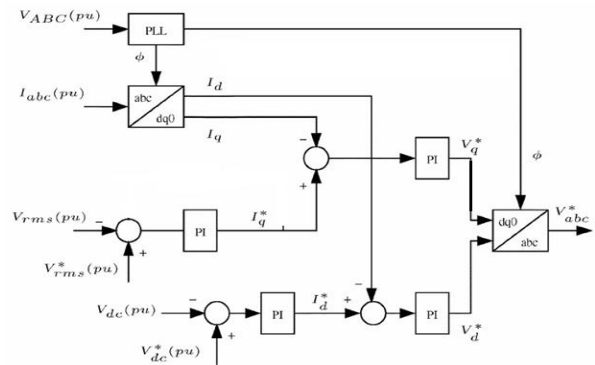

Fig.5 Block Diagram of DSTATCOM Control

3.4 Problem Of DC Link PI Control

At steady state the average power is updated every half cycle during this time, the power to the load is supplied temporarily from the DSTATCOM. This leads to a decrease in dc link voltage if load is increased or an increase in capacitor voltage if the load is reduced. For good compensation, it is important that the capacitor voltage remains as close to the reference value as possible.

4.FUZZY LOGIC FUNDAMENTALS

4.1 Introduction:

“What makes society turn is science, and the language of science is math, and the structure of math is logic, and the bedrock of logic is Aristotle, and that’s what goes out with fuzzy.”
— Bart Kosko

- Fuzzy logic is a powerful problem solving methodology introduced by Lotfi Zadeh in 1960’s.
- It provides tools for dealing with imprecision due to uncertainty and vagueness, which is intrinsic to many engineering problems.
- level of abstraction originating from our knowledge and experience.

5.MATLAB AND SIMULINK

5.1. Introduction

In this chapter important points in carrying out the simulation, simulation principles, advantages of simulink, and Fuzzy Logic tool boxes are presented.

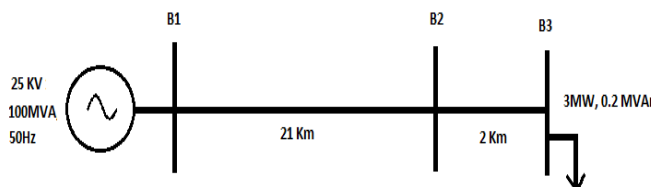

Fig.6:Test system

5.2. Fuzzy Logic Tool Box

It is a readymade Tool Box which generates the required linguistic variables in any desired standard shapes (i.e., triangular, trapezoidal

and bell). The Fuzzy inference rules are also can be written in it, linking the input and output sets.

6.SIMULINK MODELS AND TEST RESULTS

6.1 Test System

The test system shown in figure 6.1 comprises of 25KV, 100 MVA, 50Hz system feeding a distribution network of 600V through a 25KV transmission network. The transmission network comprises of 3 buses.

Between B1 and B2 a 21KM feeder of $R=0.1153$ Ohm/KM and $L=1.048e-3$ H/KM is connected. Between B2 and B3 a 2km feeder and a RC load of 3MW and 0.2MVAR are connected.

To Bus-3 a 25KV/600V , 6MVA transformer is connected to which a variable load of 3000A, 0.9Pf and a nonlinear load comprising of a 3-Phase full wave rectifier with a power load of 10KW and 10KVAR are connected.

In this thesis the above test system was implemented in MATLAB Sim-power systems. This section is divided into three cases.

Case(1) Without DSTATCOM

Case(2) DSTATCOM Voltage controller

Case(3) DSTATCOM voltage controller with Fuzzy controller

6.2 Without DSTATCOM

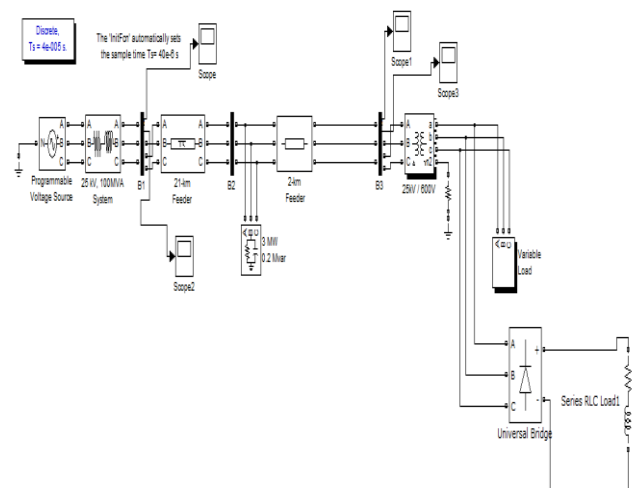

Case(1) Without DSTATCOM

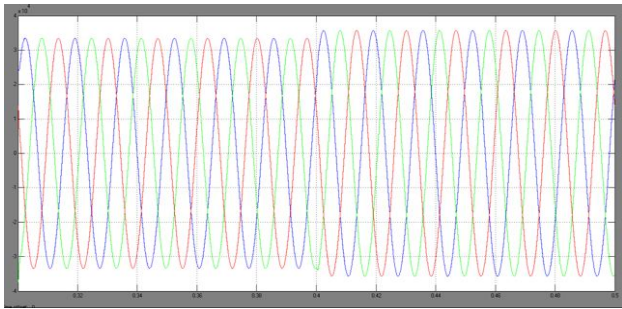

Fig.7: Three phase Voltage at Bus-3 without DSTATCOM

Using programmable voltage source a voltage swell of 1.077 pu is created at 0.4 seconds as shown in the above figure.

6.3 DSTATCOM Voltage Controller

Case(2) DSTATCOM Voltage controller

DSTATCOM is connected to Bus-3 through 1.25/25 Kv Linear transformers. The compensation capacity of DSTATCOM is +/- 3 MVAR and the voltage level of Dc Link is 2400V. The capacitance of DC Link is 10000 Microfarads.

Figure 6.5 shows the simulink model of DSTATCOM implemented..

During the process of voltage regulation , the voltage controller tries to keep the capacitor voltage constant to produce the reference voltages. Because the output voltage of the converter depends on the capacitor Dc voltage.

D-STATCOM
25kV, +/- 3Mvar
Average Model

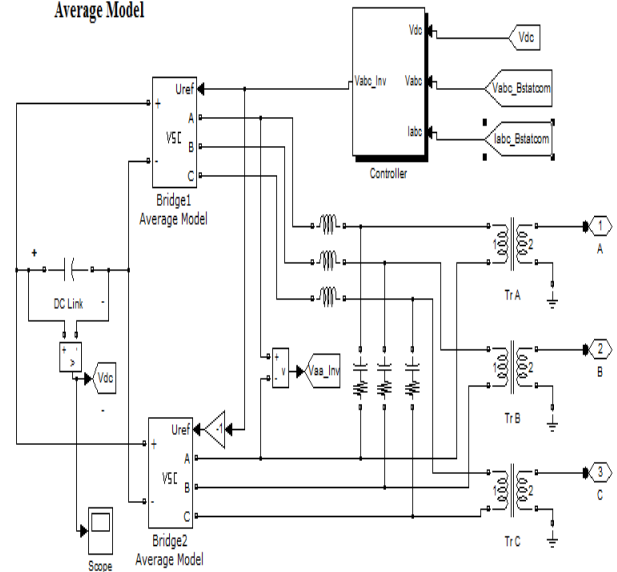
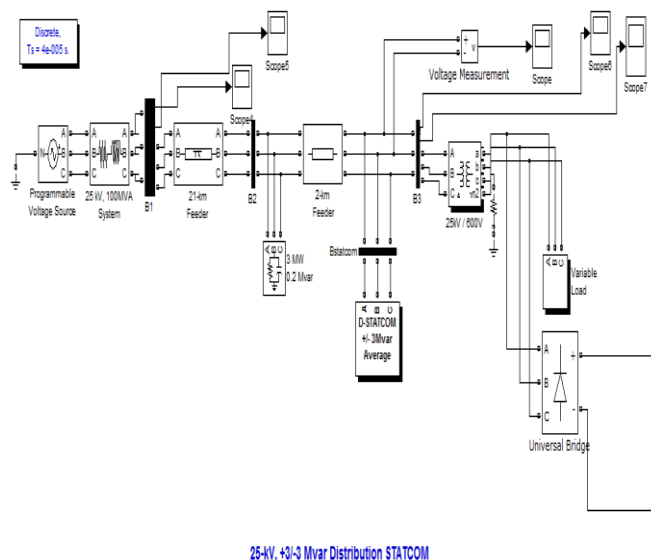

Fig. 9: Simulink model of DSTATCOM

In the above figure Simulink model of DSTATCOM is shown which consists of two Voltage Source Converters connected in cascaded form by a Dc link which acts as a voltage source for the two inverters. The V_{ref} input given to the VSC is generated by the voltage controller .Based on the V_{ref} generated the average model of VSC will generate its output voltage.



25-kV, +/-3-Mvar Distribution STATCOM

Fig.8: Simulink model with DSTATCOM

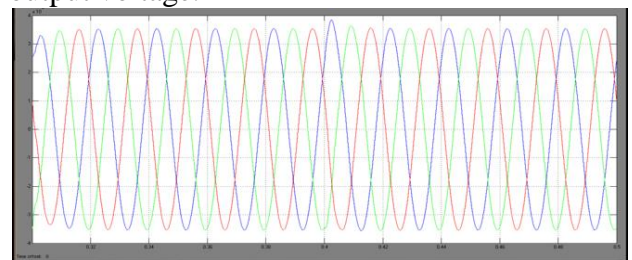

Fig.10: Load Voltage (PCC voltage) waveforms with DSTATCOM

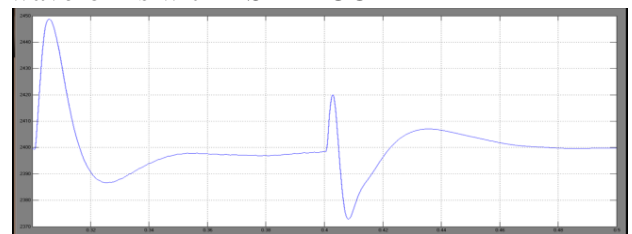

Fig. 11: Dc Link voltage of DSTATCOM

There is a considerable variation in the DC link voltage due to sudden voltage swell created at 0.4sec as shown in Fig. 10.For good

compensation, it is important that capacitor voltage remains as close to the reference value as possible. This is done by using Fuzzy logic supervision of Dc link PI control which will be discussed in next case.

6.4 Fuzzy Logic Based Supervision Of DC Link PI Control

Case (3): DSTATCOM voltage controller with Fuzzy logic based supervision of DC Link PI control

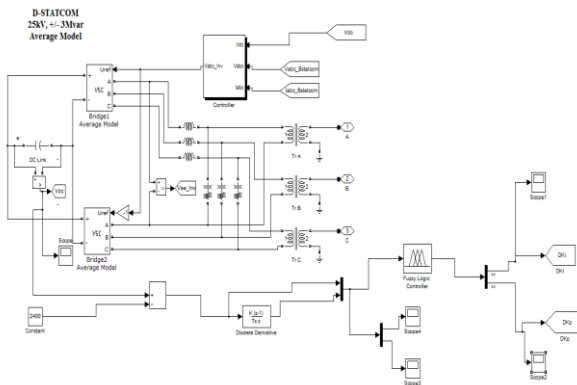

Fig. 12: Fuzzy logic supervisor implemented for DC link PI control

The membership functions for error and change in error of DC link voltage are as shown in Fig.13 and Fig.14. The membership functions for change in K_p and change in K_i are as shown in Fig.15 and Fig.16

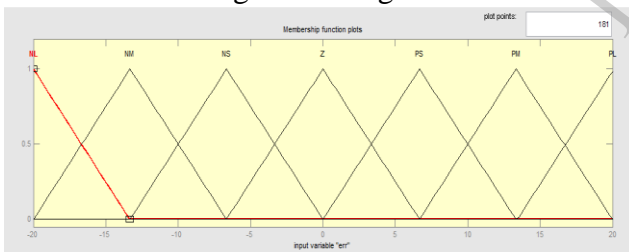

Fig 13: Membership functions for error input

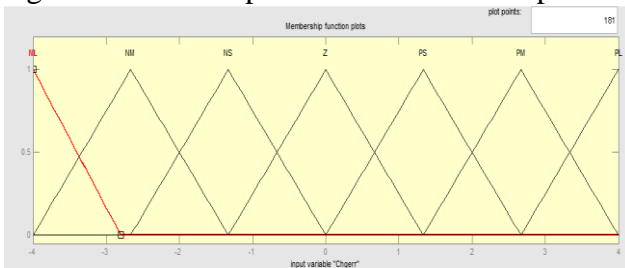

Fig. 14 Membership functions for change in error input

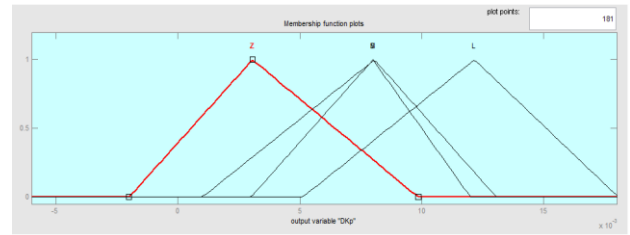

Fig 15 Output membership functions for Change in K_p

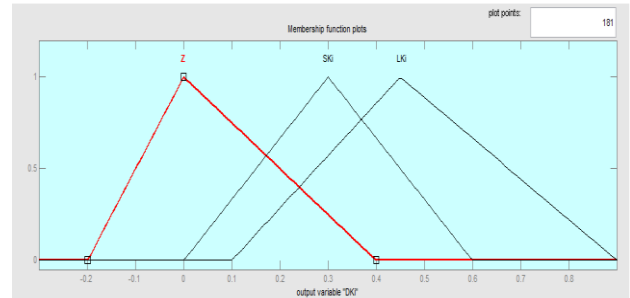

Fig 16 Output membership functions for change in K_i

The defuzzified outputs of fuzzy logic supervisor i.e. change in K_p and change in K_i values at each and every instant of time are as shown in Fig.17 and Fig.18

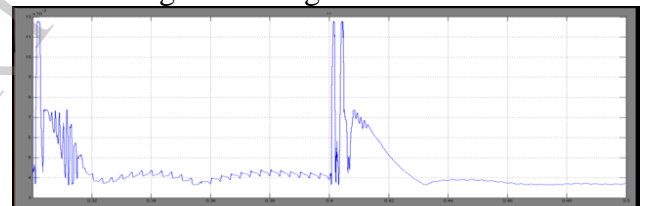

Fig17 Defuzzified outputs of change in K_p

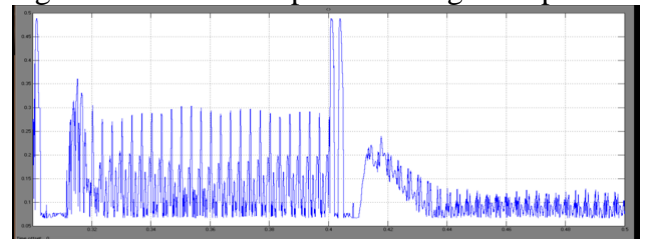

Fig18 Defuzzified outputs of change in K_i

Figure 18 shows the addition of Fuzzy supervisor outputs i.e. defuzzified outputs shown in Fig.19 to the proportional and integral gains of PI controller employed for DC link voltage control.

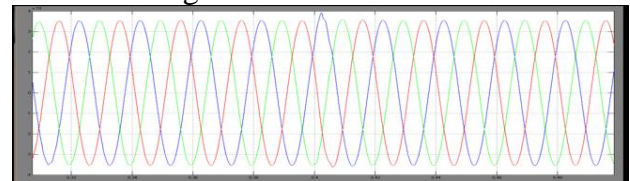

Fig.19 Load voltage (PCC voltage) with Fuzzy supervision of Dc Link PI control.

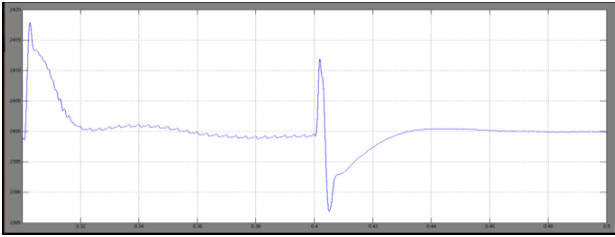

Fig. 20 DC link Voltage with Fuzzy supervision

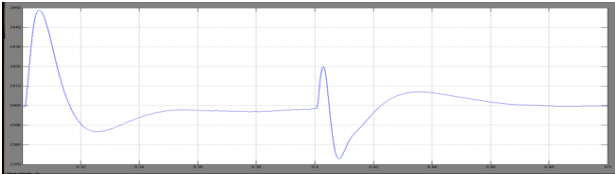

Fig. 21 Dc Link voltage of DSTATCOM without Fuzzy supervisor

6.5 Comparison Of DC Link Capacitor Voltage Of DSTATCOM Without And With Fuzzy Logic Supervision

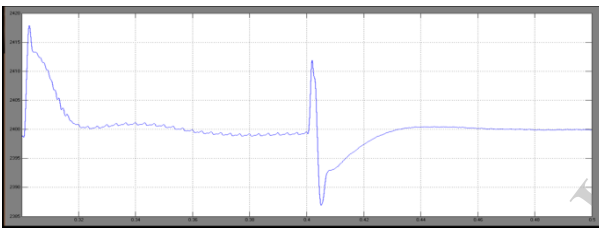

Fig. 22 DC link Voltage with Fuzzy supervision

By comparing the DC link voltages without Fuzzy supervision and with Fuzzy supervision from Fig.21 and Fig.22 respectively the following conclusions are drawn.

1. A 50-60% reduction in the error in dc link capacitor voltage compared to a normal PI controller is obtained and also voltage waveform has a faster settling time.

2. From Fig. 13 and Fig. 21 it can also be concluded that a good voltage control is also achieved by implementing Fuzzy logic supervisor for DC link PI control.

CONCLUSION

A fuzzy logic supervisor to the dc link PI controller of the DSTATCOM has been proposed. The supervisor varies the gain of the PI controller during the transient period in a way that improves performance. The system has been modeled and simulated in the MATLAB technical environment.

The performance of the dc link and compensation were observed with and without the fuzzy supervisor. Simulation result show a 50-60% reduction in voltage deviation of the dc link voltage with faster settling time. Good compensation has been observed. Thus, through simulation studies, the implementation of a fuzzy supervisor for DC link voltage control in a DSTATCOM for load compensation has been demonstrated.

REFERENCES

- [1] A. Ghosh and G. Ledwich; "Power Quality enhancement using custom power devices," Kluwer Academic Publishers, Boston, 2002
- [2] N. Hingorani, "Introducing Custom Power," *IEEE Spectrum*. Vol. 32, no. 6 pp. 41-48, 1995.
- [3] H. Akagi, Y. Kanazawa, and A. Nabae, "Instantaneous reactive power compensators comprising switching devices without energy storage components," *IEEE Trans. on Ind. Appl.* Vol. 20, no. 3, 625-630, 1984.
- [4] F. Z. Peng and J. S. Lai, "Generalized instantaneous reactive power theory for three-phase power systems," *IEEE Trans. on Instrumentation and Measurement*. Vol. 45, no. 1, 293-297, 1996
- [5] H. Kim, F. Blaabjerg, B. B. Jemsen and J. Choi, "Instantaneous power compensation in three-phase systems by using p-q-r theory," *IEEE Trans. on Power Electronics*, Vol. 17, no 5, 701-709, 2002.