

Study of Various Photovoltaic Module Interconnections under Partial Shading Condition

Ms. Vaishnavi P. Deshpande
Jhulelal Institute of Technology

Dr Sanjay B. Bodkhe
Shri Ramdeobaba College of Engg & Management

Abstract- Partial shading is the most common mismatch problem in a PV system that affects system performance. The present study investigates the effects of partial shading on series connected; TCT connected and SP connected solar PV modules and compare their performance. A MATLAB simulation model that represents 28 cells PV module is tested under partial shaded conditions and varying irradiance condition to find the interconnection which is less susceptible to partial shading effects. It is found that the traditional series interconnection scheme of solar module is found more sensitive to disparate solar irradiation levels with multiple power peaks while the SP and TCT interconnections are comparatively less sensitive. The effects of unavoidable partial shade can be decreased by using alternative topologies. In the present study, the solar cell interconnections inside a PV module are also modified to minimize the losses caused by partial shading effect.

Keywords— Energy sources, renewable energy system, partial shading, simulation, solar photovoltaic cell

1. INTRODUCTION

Solar electricity is essential source of electrical energy because of the increasing prices and scarcity of fossil petroleum. Environmental issue such as global warming is also the cause that favours the development of photovoltaic (PV) power [1]. In photovoltaic systems, semiconductor materials convert the solar light into electrical energy. The solar cell PV characteristic varies with irradiation and temperature [1] Solar Cell Performance is mostly affected by Partial shading. In many applications, such as solar power plants, building integrated photovoltaic or solar tents, the solar photovoltaic arrays gets illuminated non-uniformly. The shadow of clouds, the trees, booms, neighbour's houses, or the shadow of one solar array on the other, etc are the often causes of non-uniform illumination. In a large PV system occupying a wide area of land, moving clouds can also lead to partial shading. In building integrated PV systems, PV modules are installed to fit the building outer wall which leads to partial shading [1,2]. Partial shading is the most common mismatch problem in a PV system that affects IV relations. Shading can be characterized as a 'drop in direct beam irradiance' relative to the surrounding environment [3]. The shading on a PV array can result in complete or partial loss of irradiance. The losses occur because the maximum power point (MPP) of the partially shaded cells become unsynchronized with that of the uniformly irradiated cells and it is not possible to draw a unique current while operating at multiple MPPs simultaneously [3]. During Partial shading in a series connected string of cells, few cells under shade produce less

current but these cells are forced to carry the same current as the other fully illuminated cells. The shaded cells may get reverse biased, acting as loads, draining power from fully illuminated cells this leads to hot-spot problem [4].

In series connected string module's output power curve shows the multiple peaks under partial shading. Multiple peaks are produced as the cells in series carry different currents due to shading [6]. As occurrence of partially shaded conditions being quite common shade analysis of modules is essential. In the recent years the advancement of PV is responsible for its widespread expansion. The electric grids have precise voltage levels. In order to interface the PV generators with the grid, the PV cells are connected in series to form PV modules. A number of PV modules are connected in series/parallel to form a solar array for a desired voltage and current level. A photovoltaic array is the complete power-generating unit, consisting of any number of PV modules and panels. The flexibility of the modular PV system allows designers to create solar power systems that can meet a wide variety of electrical needs [5]. Fig 1 Shows PV cell, Panel (Module) and Array.

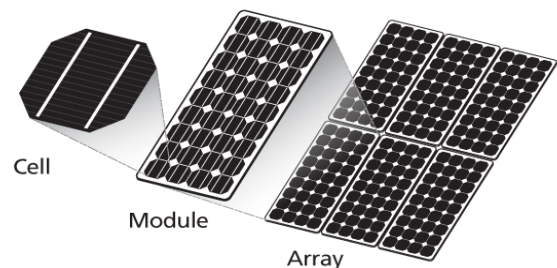

Fig 1. PV cell, Panel (Module) and Array

The existing literature focusses on adverse effect of partial shading i.e. multiple peak in output power curve and hot spot problem in series connected module. These problems can be partially solved by using different PV module interconnections. Thermal effect on the solar PV interconnections and its influence on the output power and efficiency is studied [7]. The mismatch losses and due to tracking of local MPP instead of the global one for string configurations is studied in [8]. Analysis on the various array configurations under changing illumination conditions is presented in [9]. In [10], a Su Do Ku puzzle pattern in a TCT connected PV array has been proposed to improve the PV power generation under partial shaded conditions. The various partial shading losses due to the false tracking and fill factor under changing illumination conditions is

investigated by using a MATLAB/Simulink model[5]. In this paper PV module interconnections such as Series, TCT and SP are studied and tested with varying irradiance and partial shading condition both to observe its effect on output power. The comparative analysis of all the three modules with varying irradiance and partial shading condition is presented. In this study three modules are designed (each having 28 solar cells) with Series, Series Parallel and Total Cross Tied connection and simulated to compare the output power curve. Study of physical Solar PV module is difficult as field testing depends heavily on the varying weather conditions. It is difficult to maintain the same shade throughout the experiment. To avoid this, a simulation study is carried out with the help of a computer model in MATLAB Simulink [11]. This paper is arranged as follows: First section describes design of TCT, SP and Series connected module. The following sections discuss simulation at varying irradiance and partial shading conditions. Finally, the simulation results are discussed.

2. DESIGN OF MODULE

In a PV module the solar cells interconnections can be series or SP or TCT. In the present study three different PV modules are considered by connecting PV cells in series, in TCT and in SP connection respectively. Fig. 2.1, Fig. 2.2 and Fig. 2.3 shows PV Modules each of 28 solar cells (approximately 120 Watts) connected in Series connection, series-parallel connection and TCT connection respectively. Each module contain bypass diodes to prevent damage from reverse bias on partially shaded cells.

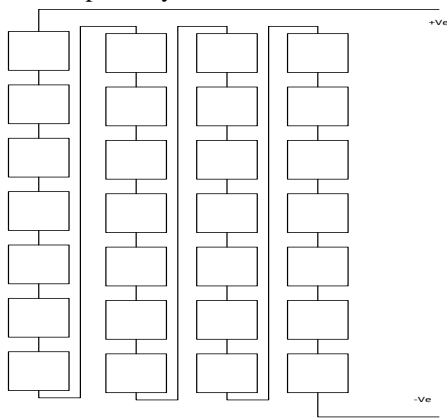

Fig 2.1 Series Connected Module (28 Solar cells forming string)

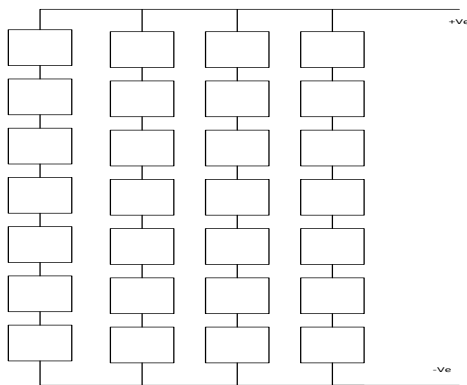

Fig 2.2 SP Connected Module (28 Solar cells)

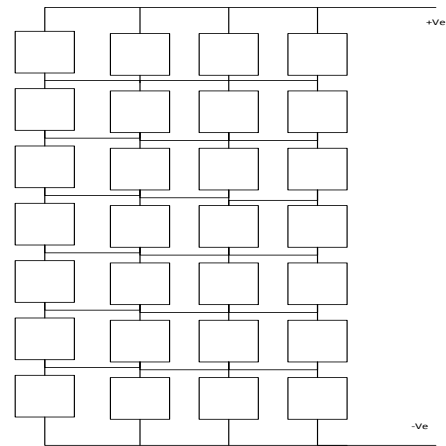

Fig 2.3 TCT Connected Module (28 Solar cells)

3. MODULE TESTING

In module testing, generally partial shading test is carried out to judge the performance of PV system. In this study along with partial shading test, varying irradiance test is also carried out as an array is not always partially shaded but its performance may also get affected due to overall reduced irradiance or changing weather conditions. Both the test are carried out to observe the result.

3.1 Varying Irradiance Test

The Series module, TCT module and SP module are tested under varying irradiance condition in Matlab Simulink. First the modules are simulated considering standard STC condition. The value of irradiance then decreased in the steps of 200w/m^2 from 1000w/m^2 - 200w/m^2 . The observations are presented in Fig 3.1 P_{max} vs Irradiance chart. On x-axis irradiance is plotted in the range of (1000w/m^2 - 200w/m^2) & on y-axis P_{max} is plotted in watts. For more clarity in results irradiance grouping is done in two conditions namely 1) Full irradiance condition and 2) Average irradiance condition. The results are discussed as follows.

Full Irradiance Condition ($G=1000\text{W/m}^2$ - 800w/m^2)

At full irradiance of (1000w/m^2 - 800w/m^2), P_{max} of series module is found higher than TCT & SP module. TCT & SP modules have more interlink connections leading to more losses.

Average Irradiance Condition ($G=600\text{w/m}^2$ - 200w/m^2)

At Average Irradiance Condition (600w/m^2 - 200w/m^2), P_{max} of all the three modules are found approximately equal.

PMAX VS IRRADIANCE

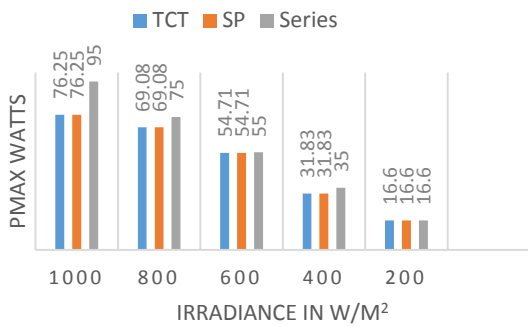

Fig 3.1 Comparison of P_{max} (MPP) at varying irradiance condition.

These observations indicate that 1) At full irradiance condition series connected PV modules gives higher output than other two topologies. But full irradiance i.e. standard STC condition is rare. So, average irradiance condition play vital role in topology selection. 2) At average irradiance condition it is found that all the three modules produce approximately equal output power.

3.2 Partial Shading Test

In order to study partial shading effect more practically instead of shading cells in the modules, a 3_3 TCT configured array is modelled using TCT module, SP module, series module as shown in figure. These arrays are simulated for 25%, 50%, and 75% shading condition. The shaded arrays are shown in figure 3.2

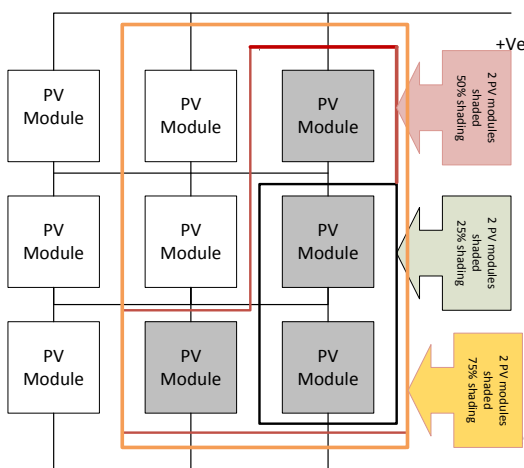

Fig 3.2 A TCT array showing shading conditions.

Three arrays of 1KW with TCT module, SP module and Series module are modelled. These arrays are simulated at partial shading condition of 25%, 50%, and 75%. The results are discussed as follows

4. RESULTS AND DISCUSSION

A 3_3 TCT configured 1KW Array (module internally connected in series called string) is tested for partial shading conditions. The output power curves are shown in Fig 4.1

for 25% shading (red), 50% shading (green), and 75% shading (yellow).

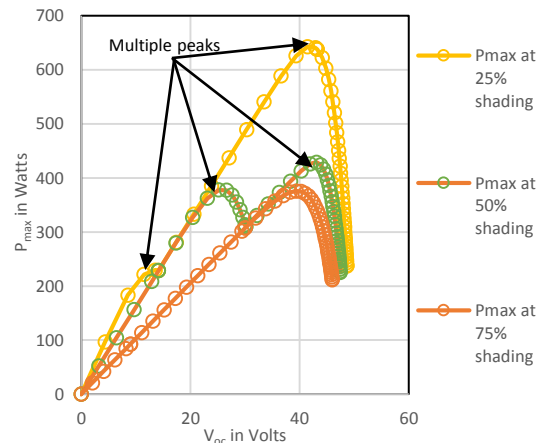

Fig. 4.1 PV curve of Series module at partial shading

The PV module is tested first at Irradiance=1000w/m², shading of 25% (two modules shaded), V_{oc} =48v, I_{sc} = 16.1A and P_{max} of P_1 =640 watts & P_2 =235 watts i.e. Multiple peaks. Then 50% shading (4 modules shaded) is carried out with V_{oc} =47V, I_{sc} =16A and two multiple peaks of P_1 =428watts and P_2 =378 watts. In 75% shading (6 modules shaded) V_{oc} =45V and I_{sc} =10.28 with multiple shading. In 75% shading the multiple peaks are not clear due to the TCT array structure. The PV curve of series module shows presence of multiple peaks at various shading conditions. Under shading conditions modules receiving non-uniform irradiance produces different currents producing multiple peaks. This condition reduces the effectiveness of the existing MPP tracking (MPPT) schemes, which assume a single peak power point on the P - V characteristic. The occurrence of partially shaded conditions being quite common (e.g., due to clouds, trees, etc.), there is a need to develop special MPPT schemes that can track the GP under these conditions. This leads to use of global MPPT algorithm.

A 3_3 TCT configured 1KW Array (module internally connected in SP

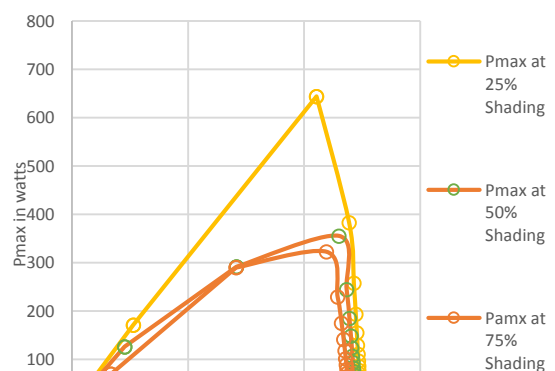

Fig. 4.2. PV curve of SP module at partial shading

A 3_3 TCT configured 1KW Array (module internally connected in SP) connected module's output power curve Fig 4.2 shows the unique power point on the output power curves. The maximum power point goes down as the partial shading increases. The PV module is tested first at Irradiance=1000w/m², shading of 25% (two modules shaded), V_{oc}=12.4v, I_{sc}= 64.5A and P_{max} =616.6 watts. Then 50% shading (4 modules shaded) is carried out with V_{oc}=12.1V, I_{sc}=61.2A and P_{max}=350watts. In 75% shading (6 modules shaded) V_{oc}=12V and I_{sc}=41A and P_{max}=332Watts.

A 3_3 TCT configured 1KW Array (module internally connected in TCT)

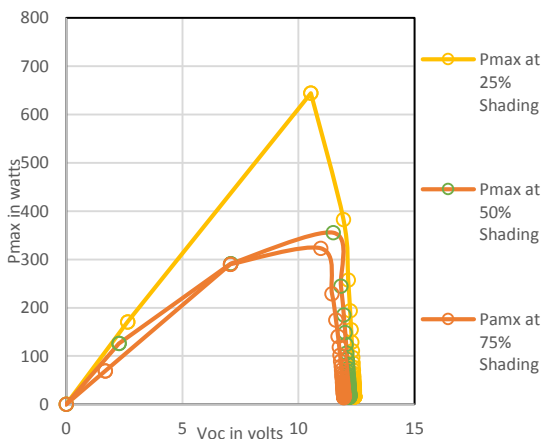

Fig. 4.3. PV curve of TCT module at partial shading

A 3_3 TCT configured 1KW Array (module internally connected in TCT) connected module's output power curve Fig 4.3 shows the unique power point on the output power curves same as SP module. The maximum power point goes down as the partial shading increases

The results indicate that series connected module (forming an array) get seriously affected by partial shading than SP and TCT connected module array.

5. CONCLUSION

Series connection of solar cells in an array is essential to get practically utilisable voltage. A number of such strings are connected in parallel to get the requisite power. As there is a substantial power loss due to non-uniform illumination of a series string a new approach for PV module interconnection under shadow conditions has been discussed in this study. In varying irradiance study it is concluded that, in the average irradiance condition all the three modules produces equal power output. In India most of the regions come under average irradiance. So solar arrays built with TCT module, SP modules found more effective & reduces the risk of hot spot phenomenon.

In partial shading study it is concluded that arrays with series modules produces multiple peaks which misleads MPP. The TCT & SP modules work satisfactory on partial shading condition giving unique maximum power point. In this study it is observe that TCT and SP modules can work more efficiently than series module under both condition.

REFERENCES

- [1] Yaw-Juen Wang, and Po-Chun Hsu, "Analysis of Partially Shaded PV Modules Using Piecewise Linear Parallel Branches Model," World Academy of Science, Engineering and Technology International Journal of Electrical, Computer, Energetic, Electronic and Communication Engineering Vol:3, No:12, 2009
- [2] Nguyen D. and Lehman B, " An Adaptive Solar Photovoltaic Array Using Model-Based Reconfiguration Algorithm," IEEE Transactions on Industrial Electronics ,vol.55, no.7, pp.2644-2654, July 2008
- [3] Storey, J.; Wilson, P.R.; Bagnall, D., "The Optimized-String Dynamic Photovoltaic Array," Power Electronics, IEEE Transactions on , vol.29, no.4, pp.1768,1776, April 2014
- [4] Quaschnig V. and Hanitsch R., "Numerical simulation of current-voltage characteristics of photovoltaic systems with shaded solar cells," Solar Energy, vol. 56, no. 6, pp. 513–520,1996.
- [5] Vijayalekshmy S, Bindu G R, and S Rama Iyer, "Estimation of Power Losses in Photovoltaic Array Configurations under Passing Cloud Conditions," Proceedings of the World Congress on Engineering Rauschenbach Hans. S, "Electrical output of Shadowed Solar Arrays. (1971). IEEE Transactions on Electron Devices, Vol,ED-18, No.8, pp 483-490
- [7] Dhass A.D., Natarajan E., Lakshmi P, " An Investigation of Temperature Effects on Solar Photovoltaic Cells and Modules," IJE TRANSACTIONS B: Applications Vol. 27, No. 11, (November 2014) 1713-1722
- [8] Anssi Maki, Seppo Valkealahti, "Power Losses in Long String and Parallel-Connected Short Strings of Series- Connected Silicon-Based Photovoltaic Modules due to Partial Shading Conditions" IEEE Transactions on Energy Conversion, Vol 27, No 1, ,pp. 173-183, March 2012
- [9] Vijayalekshmy S, S Ramalyer, Bisharathu Beevi, " Analysis of Solar Photo Voltaic Array Configurations under Changing illumination conditions". IEEE Conference Proceedings of International Conference on Circuits, Power, Computing and Telecommunication, Nagercoil, pp 1032-1037, March 2014
- [10] B InduRani ,G Sarava Ilango and Clilakapati Nagamani, "Enhanced power generation from PV array under partial shading conditions by Shade dispersion using Su Do Ku configuration", IEEE Trans on Sustainable Energy. April 2013
- [11] Patel H. and Agarwal V., "Maximum power point tracking scheme for PV systems operating under partially shaded conditions," IEEE Trans. Ind. Electron., vol. 55, no. 4, pp. 1689–1698, Apr. 2008.