

Structural Behaviour of Cantilever Retaining Wall with Pressure Relieving Shelves

Jyoti P. Bhusari

Professor, Department of Civil Engineering,
Sinhgad College of Engineering,
Pune, India.

Rajashri S. Ghodke

Department of Civil Engineering,
Sinhgad College of Engineering,
Pune, India.

Abstract: Earth retaining walls are an essential part of almost all infrastructural projects, to support backfill. High retaining structures are uneconomical and bulky in size because of higher bending moment at stem bottom. Providing shelves with retaining wall gives excellent & economical solution to this problem. This paper presents the parametric study to recognize the effect of number of shelves, width of shelves and shelf position on the lateral earth pressure distribution, top wall movement and the maximum bending moment on the wall with shelves. Reduction in lateral thrust due to provision of relief shelf reduces the bending moment at the stem bottom. The present study reveals that the cantilever retaining wall with single relief shelves can reduce bending moment at the bottom of stem up to 70%, compared to that of a retaining wall without relief shelf. The economic shelf location for cantilever retaining wall with single shelf is at 0.4h to 0.5h from top of the stem, where h is height of stem. The deflection of the stem is reduced by about 95% by providing shelf. Retaining wall with two shelves of 1.5 m and 2 m shelf widths positioned at 0.35h and 0.55h is recommended and it decreases bending moment at bottom of stem by about 65% and top node displacement by about 70%. Retaining wall with two shelves 2 m and 2.5 m shelf widths positioned at 0.35h and 0.65h shows better performance and it decreases bending moment by about 78% as well as decreases node displacement by about 90% along with nearly uniform earth pressure beneath the base slab.

Keywords: Earth pressure, Finite element method, Retaining wall, Relief shelf

I. INTRODUCTION

A retaining wall is a structure designed and constructed to resist the lateral pressure of soil, when there is a desired change in ground elevation that exceeds the angle of repose of the soil. Gravity wall, cantilever retaining wall, sheet pile retaining wall, bored pile retaining wall, anchored retaining wall are the types of retaining walls are generally used. Rigid non-yielding high retaining walls are made usually as gravity retaining walls. These walls are bulky in size. However, massive gravity walls may not be viable due to economic and space constraints. Also, in some cases, sufficient yielding of rigid cantilever retaining walls may not be permitted due to site constraints, and these walls need to be designed for higher earth pressures, than the active earth pressures. One alternative to tackle such issues is to reduce the lateral thrust on the wall. There are many techniques available to reduce the earth pressure, such as use of light weight backfill. An attempt has been made to understand the behaviour of cantilever retaining wall with relief shelves and hence to explore the effectiveness of shelves to reduce the earth pressure and the bending moment on the wall [1, 2, 4, 7].

A pressure relief shelf is a thin horizontal cantilever platform of finite width, extending into the backfill at right angles, throughout the length of the retaining wall, constructed monolithically with the stem of the retaining wall. Use of relief shelf not only reduces the lateral earth pressure but it also gives economic design and increase in overall stability [5, 6]. Klein gives two distributions of the lateral earth pressures that are for the shelf that is not extended to rupture line (short shelf) and shelf that is extended to the rupture line (long shelf) [3]. The parameters affecting the design of cantilever retaining wall with shelves are number of shelves, position of shelves and width of the shelves [9, 10, 11]. This paper presents parametric study of these aspects affecting the design of wall using shelves. An attempt is made to find the best position for shelves and also suitable width of shelves by considering the effect of short shelf and long shelf. The variation in maximum base pressure (P_{max}) and minimum base pressure (P_{min}) at base is also studied.

II. METHODOLOGY

To conduct this parametric study, 14 m high retaining wall is selected and analysed using Staad pro V8i. Analysis has been carried out by considering cohesion less backfill of unit weight 20 kN/m³ and angle of internal friction of 30°. Coefficient of friction between base slab and backfill soil is 0.55 and bearing capacity of 300 kN/m² is considered. Thickness of stem at top of retaining wall is 0.3 m which increases linearly to 1 m at junction of stem and base slab. The thickness of base slab is 1.2 m and projection of base slab towards toe is 1.5 m. The base width is considered as one of a parameter for study and is varied as 7 m, 6.5 m and 6 m. Thickness of relief shelf is taken as 0.6 m. The schematic sketch of the retaining walls considered for study is given in Fig. 1.

Three groups of models are created. Group 1 consists of retaining wall without shelf with varying base widths 7 m, 6.5 m and 6 m. Group 2 consists of retaining wall with single shelf. In this group, the position of the single shelf is varied from 0.1 to 0.9h with the interval of 0.1h, where h is height of stem of cantilever retaining wall. This study is done for 3.5 m, 4 m and 4.5 m shelf width with further variation in base widths as 7 m, 6.5 m, 6 m. Group 3 consists of cantilever retaining wall with two shelves with the position of shelves varied between 0.3h to 0.7h for shelf widths of 1.5 m, 2 m and 2.5 m.

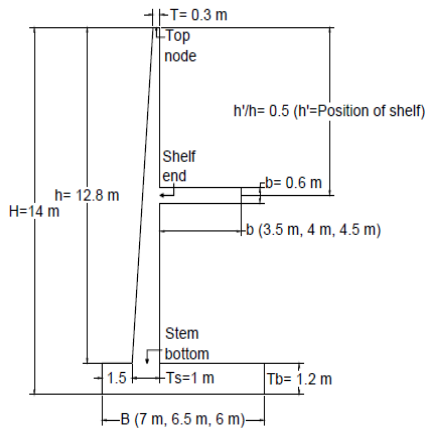

Fig. 1. Section of retaining wall

Further the variation in base widths of 7 m, 6.5 m, 6 m is also done. Selection of number of relief shelves for a given height of retaining wall should be done in such a way that width of relief shelves should not be very large as well as sufficient gap should be available between two successive relief shelves for proper compaction of backfill during the construction. Hence, for 14 m high retaining wall, 2 relief shelves are chosen for the present analysis. All retaining walls are subjected to lateral earth pressure and analysed using Klein's solution. Table I gives the details of these groups of models.

TABLE I : GROUP OF MODELS

| Group of models | Model |
|-----------------|--|
| Group 1 | Retaining wall without shelves, Base width = 7 m, 6.5 m, 6 m |
| Group 2 | Retaining wall with single shelf, For position of shelves = 1) 0.1h, 2) 0.2h, 3) 0.3h, 4) 0.4h, 5) 0.5h, 6) 0.6h, 7) 0.7h, 8) 0.8h, 9) 0.9h 1. Base width = 7 m, Shelf width = 3.5 m, 4 m, 4.5 m 2. Base width = 6.5 m, Shelf width = 3.5 m, 4 m, 4.5 m 3. Base width = 6 m, Shelf width = 4 m, 4.5 m |
| Group 3 | Retaining wall with two shelves, For position of shelves = 1) 0.35h & 0.65h, 2) 0.45h & 0.65h, 3) 0.35h & 0.55h, 4) 0.30h & 0.70h, 5) 0.30h & 0.60h, 6) 0.30h & 0.50h, 7) 0.40h & 0.60h, 8) 0.40h & 0.70h, 9) 0.50h & 0.70h For base width = 7 m, 6.5 m, 6 m 1. Shelf widths = 1.5 m & 1.5m 2. Shelf widths = 1.5 m & 2 m 3. Shelf widths = 2 m & 2 m 4. Shelf widths = 2 m & 2.5 m 5. Shelf widths = 1.5 m & 2.5 m 6. Shelf widths = 2.5 m & 2.5 m |

I. RESULTS AND DISCUSSIONS

This section describes the results of the different models analysed to determine the bending moment at bottom of stem, bending moment at end of shelf, top node displacement and base pressures.

A. Results For Group 1 Models

Here, the cantilever wall without shelves with the variation in base width i.e. 7 m, 6.5 m and 6 m walls are analysed using Staad pro. The results of this analysis are given in Table II.

It is observed that factor of safety against overturning and sliding goes on decreasing with decrease in base widths. Factor of safety against sliding is below 1.4 for all cases. Maximum pressure below base slab (P_{max}) exceeds safe bearing capacity of soil and minimum pressure (P_{min}) value is negative. Therefore these models do not satisfy the stability conditions [12].

TABLE II : ANALYSIS OF CANTILEVER RW WITHOUT SHELF

| Base width (m) | 7 m | 6.5 m | 6 m |
|--------------------------------------|---------|---------|---------|
| FOS against Overturning | 2.20 | 1.88 | 1.59 |
| FOS against Sliding | 1.34 | 1.21 | 1.09 |
| P_{max} (kN/m ²) | 452.11 | 499.09 | 560.09 |
| P_{min} (kN/m ²) | -3.53 | -60.02 | -132.09 |
| Bending moment at stem bottom (kN-m) | 2561.8 | 2561.8 | 2561.8 |
| Bending moment at toe end (kN-m) | 794.40 | 861.26 | 945.55 |
| Bending moment at heel end (kN-m) | 2142.40 | 2042.69 | 1926.84 |
| Node displacement of top node (mm) | 86.94 | 86.94 | 86.94 |

B. Results For Group 2 Models

Retaining wall with relief shelves is different in shape compared to the conventional retaining wall and addition of horizontal relief shelves have increased the weight of wall and shifted the center of gravity of such wall towards backfill. Reduction of lateral thrust has also played a role in variation of contact pressure at base. Total contact pressure below the base slab for all retaining walls considered in the study is tabulated. It can be concluded that proper selection of width of relief shelves can reduce total contact pressure below the base slab significantly and subsequently increase the factor of safety against bearing capacity failure.

The cantilever retaining wall with one shelf and having different shelf width combinations of 3.5 m, 4 m and 4.5 m at different positions are analysed. Positions of shelf is varied between 0.1 to 0.9 times the stem height.

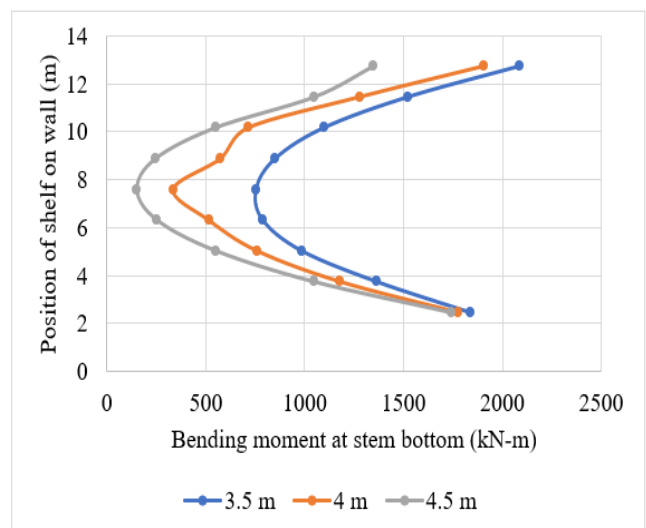

Fig. 2. Bending moment at stem bottom for various positions of shelf

The graph of bending moment at stem w.r.t position of shelf is plotted as shown in figure 2. It is observed that for all widths, the minimum bending moment at stem bottom is achieved for the shelf position at 0.5h. The bending moment for 4.5 m shelf width, positioned at 0.5h is the least amongst the three cases considered.

The graph of bending moment at shelf end w.r.t position of shelf is plotted as shown in figure 3. The graph shows observations for cantilever retaining wall with single shelf for shelf widths 3.5 m, 4 m and 4.5 m.

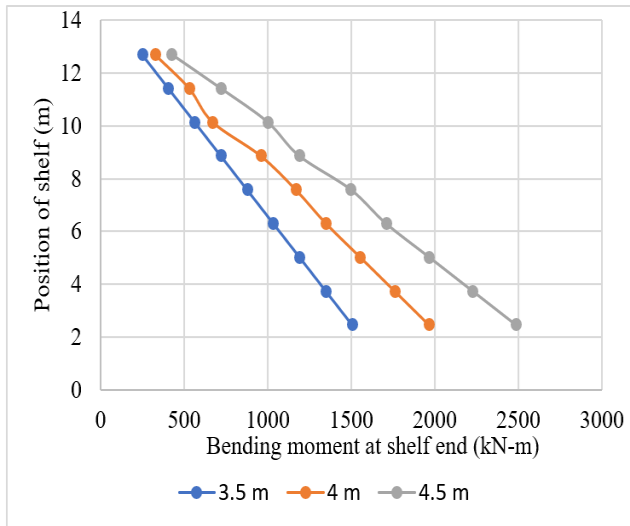

Fig. 3. Bending moment at shelf end for various positions of shelf

By the graph it is observed that for all shelf widths, the value for bending moment at shelf end increases as we go from 0.1h to 0.9h. For 3.5 m shelf width the values for bending moment at shelf end are less than that of 4 m and 4.5 m. Considering the results of bending moments at stem bottom and as well as at shelf end which shows opposite behaviour with reference to bending moment values with respect to position of shelf, the appropriate location of the position of shelf can be considered at 0.4h wherein the balanced value of bending moments at shelf end are obtained.

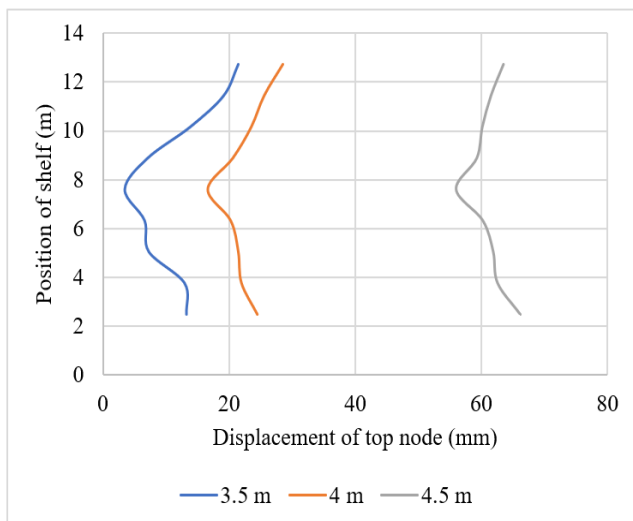

Fig. 4. Top node displacement for various positions of shelf

The graph of position of shelf w.r.t displacement of top node is plotted as shown in figure 4. From the graph, it is observed that for all widths the minimum node displacement is at shelf position 0.5h. As the shelf width increases, it is observed that there is increase in top node displacement. It is to be noted that this displacement is towards the backfill unlike in case of retaining wall without shelf, where the displacement is away from backfill. Thus introducing the shelf with rigid connection with wall decreases the displacements considerably. With change in shelf position from 0.1h to 0.9h, the node displacement decreases up to 0.5h and then increases from 0.6h to 0.9h. With increase in width of relief shelf, maximum displacement of retaining walls has been increased. This is due to the reduction of total lateral thrust on wall and increased weight of wall due to relief shelves.

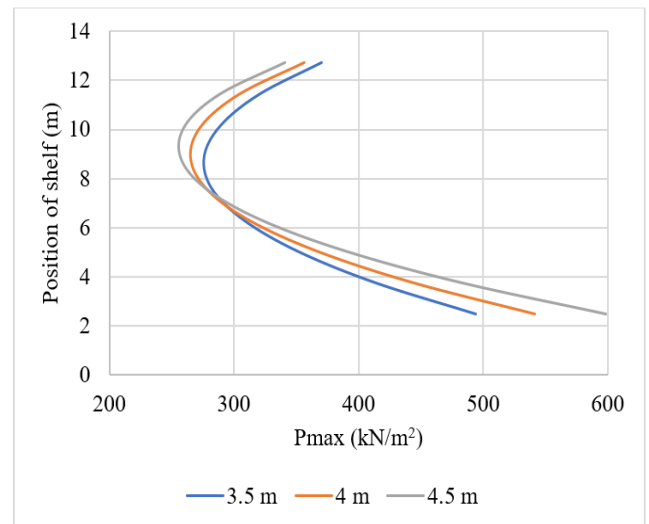

Fig. 5. Maximum base pressure for various positions of shelf

The graph of position of shelf w.r.t maximum soil base pressure (P_{max}) is plotted as shown in figure 5. As shelf positions varies from 0.1h to 0.9h, the P_{max} value decreases from 0.1h to 0.5h and then increases from 0.6h to 0.9h.

The retaining wall having the position of shelf at 0.4h and 0.5h from top are only satisfied with the stability conditions for 3.5m shelf width. Retaining wall with shelf of 4 m width positioned at 0.3h, 0.4h and 0.5h and Retaining wall with shelf width 4.5m positioned at 0.3h, 0.4h and 0.5h are the ones which satisfy the stability conditions. All other retaining walls fail in satisfying the stability conditions as the P_{max} value exceeds the safe soil bearing capacity of soil (300 kN/m²)

Considering the variation in base widths, bending moment at stem bottom, shelf end as well as top node displacement is not affected but this parameter is critical for stability fulfillment considering the maximum base pressure values. For 7 m base width pressure at base is less than that of cantilever retaining wall with base widths 6.5 m and 6 m. Models of cantilever retaining wall with 6 m base width and 3.5 m shelf width at any position do not satisfy the stability condition for base pressure so they are eliminated from analysis. Considering all the four parameters, the appropriate position

of shelf can be considered as 0.4 m. The results of these walls are compared to models of cantilever retaining wall without shelves. For cantilever retaining wall with shelf position 0.4h, the percentage decrease in bending moment at stem bottom is 70% as compared to cantilever retaining wall without shelf. And node displacement is also decreased by about 90 percent for that position.

C. Results For Group 3 Models

Cantilever retaining wall with two shelves with various shelf width in combinations of 1.5m, 2m and 2.5m at different positions are analysed. Positions of shelves are varied between 0.3 to 0.7 times the height of stem. The conditions of stability are checked and all models satisfy conditions of stability. Provision of two relief shelves has divided the whole retaining wall into three small segments. It is observed that 9 different combination of position of shelves which are practically feasible are available as mentioned in Table I and these retaining walls are considered and analyzed. Bending moment at stem bottom, bending moment at shelf end for first and second shelf are calculated. Also, node displacement at top node of stem, node displacement of free end of shelf 1 and shelf 2 is also considered for the study. It is observed that for group 2 models, values of P_{max} and P_{min} are nearly same as compared to the values of base pressures under cantilever retaining wall with one shelf. Thus, pressure distribution below the base slab is almost uniform throughout base slab. It is important to discuss here that always place higher width shelf at lower position than that of lower width shelf.

TABLE III : RESULTS OF ANALYSIS OF CANTILEVER RETAINING WALL WITH SHELF WIDTH 1.5 M & 1.5 M

| Position of shelf 1 | Position of shelf 2 | P_{max} (kN/m ²) | P_{min} (kN/m ²) | Bending moment at stem bottom (kN-m) | Top Node displacement (mm) |
|---------------------|---------------------|--------------------------------|--------------------------------|--------------------------------------|----------------------------|
| 0.45h | 0.65h | 242.5 | 234.3 | 1447 | 43.46 |
| 0.35h | 0.65h | 240.7 | 236.1 | 1468 | 43.91 |
| 0.30h | 0.70h | 237.7 | 239.1 | 1438 | 39.76 |
| 0.30h | 0.60h | 240.7 | 236.2 | 1465 | 36.65 |
| 0.30h | 0.50h | 242.6 | 234.4 | 1435 | 34.56 |
| 0.40h | 0.60h | 243.1 | 233.9 | 1422 | 39.5 |
| 0.40h | 0.70h | 240.2 | 236.7 | 1432 | 42.72 |
| 0.50h | 0.70h | 241.3 | 235.8 | 1439 | 43.25 |
| 0.35h | 0.55h | 243.2 | 233.9 | 1430 | 34.52 |

From Table III, it is observed that for shelves with width 1.5m and 1.5m, the best positions of shelves are at 0.4h and 0.6h for shelf 1 and shelf 2 respectively. Top node displacement for this condition is 39.50 mm which is about 55 percent less than that of cantilever retaining wall without shelves. Bending moment at stem bottom is 1421 kN-m which is about 45 percent less than that of cantilever retaining wall without shelf and it is also less than that of any other position of two shelves.

TABLE IV : RESULTS OF ANALYSIS OF CANTILEVER RETAINING WALL WITH SHELF WIDTH 1.5 M & 2 M

| Position of shelf 1 | Position of shelf 2 | P_{max} (kN/m ²) | P_{min} (kN/m ²) | Bending moment at stem bottom (kN-m) | Top Node displacement (mm) |
|---------------------|---------------------|--------------------------------|--------------------------------|--------------------------------------|----------------------------|
| 0.45h | 0.65h | 268 | 249 | 992 | 28.5 |
| 0.35h | 0.65h | 266 | 251 | 1120 | 23.6 |
| 0.30h | 0.70h | 263 | 255 | 1164 | 24.6 |
| 0.30h | 0.60h | 267 | 251 | 1170 | 27.4 |
| 0.30h | 0.50h | 269 | 248 | 1174 | 19.8 |
| 0.40h | 0.60h | 269 | 248 | 1046 | 26.4 |
| 0.40h | 0.70h | 265 | 252 | 1065 | 35.4 |
| 0.50h | 0.70h | 266 | 251 | 1218 | 40.5 |
| 0.35h | 0.55h | 269 | 247 | 967 | 35.2 |

The next set of model in group 2 is of cantilever retaining walls with shelf widths 1.5 m and 2 m at different positions from 0.3h to 0.7h. From Table IV, it is observed that these models have less values of bending moments at stem bottom than that of walls with shelf widths of 1.5 m and 1.5 m. Thus, when there is an increase in shelf width, the decrease in bending moment at stem bottom is observed but at the cost of increase in the bending moment at the shelf end. Therefore, it is concluded that as shelf width increases, bending moment at shelf end increases. As the shelf width increases the factor of safety against overturning and sliding increases. It is observed that the best position for this case is cantilever retaining wall and 1.5 m and 2 m shelf widths is shelf positioned at 0.45h and 0.65h for shelf 1 and shelf 2 respectively. The node displacement is 28.53 mm, that is by about 67 percent decrease as compared to retaining wall without shelves. From analyses it is observed that as the shelf width increases, the top node displacement decreases.

TABLE V : RESULTS OF ANALYSIS OF CANTILEVER RETAINING WALL WITH SHELF WIDTH 1.5 M & 2.5 M

| Position of shelf 1 | Position of shelf 2 | P_{max} (kN/m ²) | P_{min} (kN/m ²) | Bending moment at stem bottom (kN-m) | Top Node displacement (mm) |
|---------------------|---------------------|--------------------------------|--------------------------------|--------------------------------------|----------------------------|
| 0.45h | 0.65h | 293 | 265 | 713 | 27.3 |
| 0.35h | 0.65h | 291 | 267 | 767 | 22.3 |
| 0.30h | 0.70h | 287 | 271 | 902 | 23.6 |
| 0.30h | 0.60h | 292 | 266 | 766 | 25.3 |
| 0.30h | 0.50h | 296 | 262 | 715 | 18.3 |
| 0.40h | 0.60h | 295 | 263 | 670 | 26.2 |
| 0.40h | 0.70h | 289 | 268 | 806 | 30.3 |
| 0.50h | 0.70h | 290 | 268 | 775 | 38.7 |
| 0.35h | 0.55h | 296 | 262 | 674 | 27.5 |

Cantilever retaining walls with shelf widths of 1.5 m and 2.5 m are analysed with different combinations of shelf positions.

Shelf 1 positioned at 0.35h and shelf 2 positioned at 0.55h is the best position of shelves for these models. From Table V, the bending moment at stem bottom of 673.7 kN-m is observed for 0.35h and 0.55h shelf positions which is 73 percent less than that of cantilever retaining wall without shelves. The node displacement at top node is by about 68 percent less than that of retaining wall without shelves.

TABLE VI : RESULTS OF ANALYSIS OF CANTILEVER RETAINING WALL WITH SHELF WIDTH 2 M & 2 M

| Position of shelf 1 | Position of shelf 2 | P_{max} (kN/m ²) | P_{min} (kN/m ²) | Bending moment at stem bottom (kN-m) | Top Node displacement (mm) |
|---------------------|---------------------|--------------------------------|--------------------------------|--------------------------------------|----------------------------|
| 0.45h | 0.65h | 252 | 234 | 998 | 27.1 |
| 0.35h | 0.65h | 250 | 231 | 896 | 23.7 |
| 0.30h | 0.70h | 246 | 236 | 1053 | 24.4 |
| 0.30h | 0.60h | 250 | 231 | 909 | 24.5 |
| 0.30h | 0.50h | 253 | 232 | 1023 | 18.2 |
| 0.40h | 0.60h | 253 | 233 | 974 | 26.3 |
| 0.40h | 0.70h | 249 | 233 | 920 | 29.7 |
| 0.50h | 0.70h | 250 | 236 | 875 | 35.5 |
| 0.35h | 0.55h | 254 | 232 | 783 | 26.4 |

Considering the analysis of cantilever retaining wall with shelf widths 2 m and 2 m for various combinations of shelf positions, the best fit position for this combination is 0.35h and 0.55h for shelf 1 and shelf 2 respectively as shown in Table VI. The magnitude of bending moment at stem bottom is 783.3 kN-m, which is about 69 percent less than that of cantilever retaining wall without shelves. The bending moments at shelf ends are negligible as compared to bending moment at stem bottom and thereby minimum steel reinforcement will be required for designing the shelf. The node displacement at top node is 26.35 mm which is about 69 percent less than that of cantilever retaining wall without shelves.

TABLE VII : RESULTS OF ANALYSIS OF CANTILEVER RETAINING WALL WITH SHELF WIDTH 2 M & 2.5 M

| Position of shelf 1 | Position of shelf 2 | P_{max} (kN/m ²) | P_{min} (kN/m ²) | Bending moment at stem bottom (kN-m) | Top Node displacement (mm) |
|---------------------|---------------------|--------------------------------|--------------------------------|--------------------------------------|----------------------------|
| 0.45h | 0.65h | 277 | 249 | 712 | 10.3 |
| 0.35h | 0.65h | 275 | 245 | 597 | 9.95 |
| 0.30h | 0.70h | 270 | 252 | 755 | 11.3 |
| 0.30h | 0.60h | 276 | 246 | 601 | 9.29 |
| 0.30h | 0.50h | 280 | 247 | 723 | 9.63 |
| 0.40h | 0.60h | 279 | 247 | 678 | 9.24 |
| 0.40h | 0.70h | 273 | 249 | 636 | 15.2 |
| 0.50h | 0.70h | 274 | 252 | 603 | 12.3 |
| 0.35h | 0.55h | 280 | 247 | 682 | 10.7 |

Cantilever retaining wall with shelf widths 2 m and 2.5 m are analysed. From Table VII, this combination of two shelves gives better structural performance than the wall with previous case mentioned above. Here, the bending moment at stem bottom decreases, the factor of safety against overturning and sliding increases as well as decrease in node displacement is also observed. The best position for shelves for all these combinations is 0.35h for shelf 1 and 0.65h for shelf 2. Thus, the shelf of 2 m shelf width is at the 0.35 times height of stem from top node and shelf of 2.5 m is at 0.65h from top node. The bending moment at stem bottom for best position of shelves is 597.2 kN-m, which is by about 76 percent less than that of the cantilever retaining wall without shelves. And the node displacement is 9.95 mm i.e. 88 percent less than that of cantilever retaining wall without shelves.

Cantilever retaining wall with shelf widths 2.5 m and 2.5 m are analysed and from the results given in Table VIII 0.35h and 0.65h for shelf 1 and shelf 2 is the best position of shelves for these models. The bending moment at stem bottom 545.1 kN-m is given for 0.35h and 0.65h shelf positions which is 78 percent less than that of cantilever retaining wall without shelves. The top node displacement 6.87 mm is obtained for 0.35h and 0.65h shelf positions which is by about 90 percent less than that of cantilever retaining wall without shelves. This combination of cantilever retaining wall with shelves gives less bending moment at stem bottom than any other combination as mentioned above.

TABLE VIII : RESULTS OF ANALYSIS OF CANTILEVER RETAINING WALL WITH SHELF WIDTH 2.5 M & 2.5 M

| Position of shelf 1 | Position of shelf 2 | P_{max} (kN/m ²) | P_{min} (kN/m ²) | Bending moment at stem bottom (kN-m) | Top Node displacement (mm) |
|---------------------|---------------------|--------------------------------|--------------------------------|--------------------------------------|----------------------------|
| 0.45h | 0.65h | 261 | 234 | 721 | 6.35 |
| 0.35h | 0.65h | 259 | 229 | 545 | 6.87 |
| 0.30h | 0.70h | 253 | 232 | 635 | 7.25 |
| 0.30h | 0.60h | 260 | 228 | 549 | 4.16 |
| 0.30h | 0.50h | 264 | 231 | 731 | 5.23 |
| 0.40h | 0.60h | 263 | 232 | 630 | 4.23 |
| 0.40h | 0.70h | 257 | 231 | 653 | 6.22 |
| 0.50h | 0.70h | 257 | 236 | 792 | 8.22 |
| 0.35h | 0.55h | 264 | 231 | 691 | 6.52 |

IV CONCLUSIONS

The conclusions made from the results of the parametric study carried out on retaining wall with shelves are enumerated as follows.

- Providing shelves to the retaining wall leads to decrease in the lateral earth pressure on them. This decrease helps the retaining wall to be more stable and decrease the net bending moments.

- The optimised location for the single shelf is observed to be in between 0.4 h to 0.5 h considering the parameters; lateral earth pressure, bending moments and deflection.
 - The deflection of the top node of stem depends mainly on the shelf location and it decreases for the shelf located from 0.1h to 0.5h and then increases for shelf located from 0.6h to 0.9h.
 - The deflection of the stem is reduced by about 95% by providing shelf of 3.5 m at 0.5 h as compared to the deflection cantilever retaining wall without shelf.
 - The bending moment at stem bottom decreases from shelf location 0.1h to 0.5h and then increases. As the width of shelf at particular location increases then the lateral earth pressure decreases and therefore the bending moment at stem bottom decreases.
 - It is concluded that providing a single shelf at 0.4 times the height of stem from top node decreases the resulting bending moment by about 70%.
 - As the shelf width increases, the bending moment at shelf end increases and also the shelf end displacement increases, but reduces the bending moment at stem bottom predominantly.
 - As long as shelf width does not go beyond the rupture plane, stability conditions are not satisfied. Thus, the shelf width is recommended to be extended beyond the rupture surface.
 - Maximum allowable width of relief shelves should be increased from top to bottom of the wall, and it is also noted
 - that maximum allowable width of relief shelf at any height is a function of the width of relief shelf lying on it.
 - Providing two shelves for 14 m wall leads to stabilize the wall in a better way. And the factor of safety against sliding and overturning increases and nearly uniform pressure distribution is obtained beneath the base.
 - Retaining wall with combination of shelves with 1.5 m and 2 m shelf widths at 0.35h and 0.55h position respectively is recommended and it decreases bending moment at stem bottom by about 65% as well as decrease top node displacement by about 70%. Retaining wall with combination of shelves 2 m and 2.5 m shelf widths 0.35h and 0.65h position is the optimum solution and it decreases bending moment by about 78% as well as decrease node displacement by about 90%.
- [2] Chauhan V. B. and Dasaka, S. M., 2018, "Performance of a rigid retaining wall with relief shelves", *Journal of Performance of Constructed Facilities*, 32, 3, 211-219.
- [3] G. K. Klein, (1964) "Calculation of retaining walls", *Vysshaya Shkola*, Moscow
- [4] Goel, S. and Patra, N. R., 2008, "Effect of arching on active earth pressure for rigid retaining walls considering translation mode", *International Journal of Geomechanics*, 8, 2, 765-771.
- [5] Hany Farouk Shehata, 2016, "Use of retaining walls with relief shelves as an economic solution", *Proceedings of Geo-China 2016: Advances in numerical and experimental analysis of transportation geomaterials and geosystems for sustainable infrastructure*, ASCE press, 82-90.
- [6] Hany Farouk, 2015, "Effectiveness of using shelves with cantilever retaining walls", *AEI 2015: Birth and life of the integrated building*, ASCE press, 627-637.
- [7] Hatami, K., Bathurst, R. J. and Pietro, P. D., 2001, "Static response of reinforced soil retaining walls with nonuniform reinforcement", *The International Journal of Geomechanics*, 1, 4, 477-506.
- [8] IS: 456 – 2000, "Plain and reinforced concrete – code of practice", (fourth revision), Bureau of Indian Standards, New Delhi, India.
- [9] Kaveh, A. and Khayatazad, M., 2014, "Optimal design of cantilever retaining walls using ray optimization method", *Iranian Journal of Science and Technology*, 38, 1, 261-268
- [10] Moon, In-Jong, Kim, Han, Jin-Tae & Armin W. Stuedlein, 2016, "Optimal design conditions of retaining wall with relieving platform through real-scale numerical analysis", *GJBGC*, 55-65.
- [11] Ray Chaudhuri, 1973, "Design of retaining walls with relieving shelves", 295, *IRC Journal*, 35, 2, 289 - 325.

Thus it can be concluded that providing shelves to the retaining wall leads to decrease in the lateral earth pressure and thereby decrease the bending moment at stem bottom and decrease node displacement. Thus, retaining wall with shelves can be considered as an effective solution of the high retaining walls according to the study.

REFERENCES

- [1] Chauhan V. B. and Dasaka S. M., 2016, "Behavior of rigid retaining wall with relief shelves with cohesive backfill", *Journal of Geomechanics*, 3, 9, 286-292.