

# Smart Voting Machine Based on Finger Prints and Face Recognition

Nadar Rajkani Paulraj, G.Rajagopalan, M.Rajesh, S.V.Kiruthika, I.Jasmine A/P  
Dept. of Electronics and Communication Engineering  
Fatima Michael College of Engg & Tech, Madurai.

**Abstract -** Bogus (fake) voting is still major drawbacks in the Election. In AADHAR CARD the Government has all the data Base for us including finger print and Retina. Biometric Finger print devices and Web Camera are used in the Electronics Voting Machine for voter verification. We have designed a Smart Voting Machine where there is no need for the user to carry his ID which contains his required details. The person at the polling booth needs only to place his Finger in finger print scanner and capture the face identity in web camera at the counter of the polling booth, thus allowing the acquisition of an on-spot Fingerprint and Face from the voter which serves as an identification. This data is passed on to the controlling unit for the verification. The controller fetches the data from the reader and compares this data with the already existing data stored during the registration of the voters. If the data matches with the pre-stored information of the registered fingerprint and Face, the person is allowed to cast his vote. If not, a warning message is displayed on LCD and warns through the voice by this way, the person is barred from polling his vote. The vote casting mechanism is carried out manually using the keyboard. LCD is used to display the related messages, warnings and ensuing results.

**Keyword:** Voter ID; Finger Print Module; LCD; Web camera; Microcontroller.

## INTRODUCTION

Biometrics is the science and technology of measuring and analysing biological data. Biometrics refers to technologies that measure and analyse human body characteristics, such as DNA, fingerprints, eye retinas and irises, voice patterns, face recognition and hand measurements, for authentication purposes. The field of biometrics was formed and has since expanded on to many types of physical identification. Among the several human fingerprints and face recognition remains a very common identifier and the biometric method of choice among law enforcement. These concepts of human identification have lead to the development of fingerprint scanners web camera that serves to quickly identify individuals and assign access privileges. The basic point of these devices is Election Commission. According to Election Commission statistics, there were 1,378,352 EVMs in use in July 2009. Of these, 448,000 were third-generation machines manufactured from 2006 to 2009, with 253,400 from BEL and 194,600 from ECIL. The remaining 930,352 were the second-generation models manufactured from 2000 to 2005, with 440,146 from BEL and 490,206 from ECIL. (The first generation machines are deemed too risky to use in national elections because their

15-year service life has expired, though they are apparently still used in certain state and local contests.) In the 2009 parliamentary election, there were 417,156,494 votes cast, for an average of 302 votes per machine.

## BLOCK DIAGRAM

The system aims at developing a fingerprint based advanced Electronic Voting Machine (EVM) which helps in free and fair way of conducting elections which are basis for democratic country like India. This project consists of following units a Voting system, fingerprint module, web camera and ARM controller Unit. The voter first places his/her finger on the fingerprint module which checks for the authentication of the user. If the voter is the authenticated one then his/her show her face towards the web camera it will capture the picture of his/her face which check for the authentication in stored memory. If the voter is the authenticated one, he will now poll his vote in the voting system by simply pressing button against his favourite leader through a button. The control unit consists of an ARM controller, push button for different operations of EVM. The votes casted for particular candidate in that particular section of constituency is shown through an LCD display. To perform this intelligent task, ARM controller is loaded with an intelligent program written in embedded „C“ language

## ATMEGA 162:

ATMEGA 162 is Brain of this project. It has the features like AVR® 8-bit Microcontroller Fully Static Operation Up to 16 MIPS Throughput at 16 MHz, On-chip 2-cycle Multiplier, Non-volatile Program and Data Memories, 16K Bytes of In-System Self-programmable Flash Endurance:10,000 Write/Erase Cycles, Extensive On-chip Debug Support, Programming of Flash, EEPROM, Fuses, and Lock Bits through the JTAG. Dual Programmable Serial USARTs, This microcontroller suitable for industrial control and medical Systems.though your whole fingerprint is recorded, the computer takes only parts of the print to compare with other records.

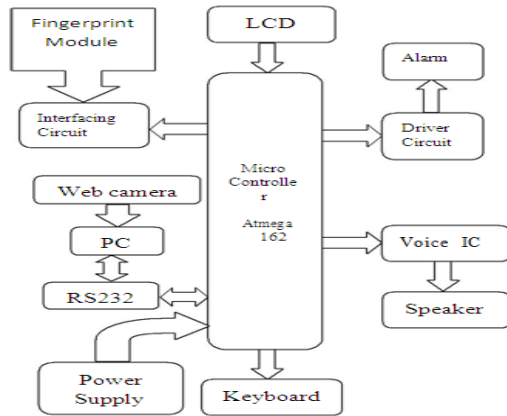

#### RS232:

In telecommunications, RS-232 is a standard for serial binary data interconnection between a *DTE* (Data terminal equipment) and a *DCE* (Data Circuit-terminating Equipment). It is commonly used in computer serial ports.

#### Power source module:

The major blocks of power supply are given below Transformer, Rectifier, Filter, 7805 voltage regulator. These will provide the regulated power supply to the unit which is first converted into 12V AC. 12V AC is converted into DC using rectifier circuit. Finally the 7805 voltage regulator provides constant 5V DC supply which will be given to circuit.

#### Keypad:

Push buttons are used in keypad. A push-button or simply button is a simple switch mechanism for controlling some aspect of a machine or a process. Buttons are typically made out of hard material, usually plastic or metal.

#### Voice IC:

MP3 mode, one to one key mode, Up to 7 kinds of operating modes : parallel mode, one record one play key mode, Audio-book mode, two-wire serial mode and three-wire serial mode, Support MIC and LINE-IN recording, Support plug-in 64M bit SPI-FLASH, recording time up to 1600 seconds, Support upload and download voice via USB.

#### Speaker:

##### Fingerprint module:

The device is the most popular among all the identification devices because of its ease in acquisition, and also the number of sources that are available for its data collection. It has found its vast use in law enforcement and immigration purposes. The module used here is R252. The basics of this identification process comes from "Galton points" – a certain characteristics defined by Sir Francis Galton, through which the fingerprints can be identified. In this module the scanned image are compared with an earlier existing finger print of yours to get the correct identity. The comparison is carried out by the processor and the comparison is made between the valleys and ridges. A loudspeaker (or "speaker") is an electroacoustic transducer that converts an electrical signal into sound. The speaker moves in accordance with the variations of an electrical signal and causes sound waves to propagate through a medium such as air or water.

##### Driver circuit:

A driver is an electrical circuit or other electronic component used to control another circuit or other component, such as a high-power transistor.

##### Alarm:

A buzzer or beeper is a signalling device, usually electronic, typically used in automobiles, household appliances such as a microwave oven, or game shows. An alarm gives an audible or visual warning about a problem or condition.

##### Web camera:

A webcam is a video camera that feeds or streams its image in real time to or through a computer to a computer network. When "captured" by the computer, the video stream may be saved, viewed or sent on to other networks via systems such as the internet.

Flow Chart:

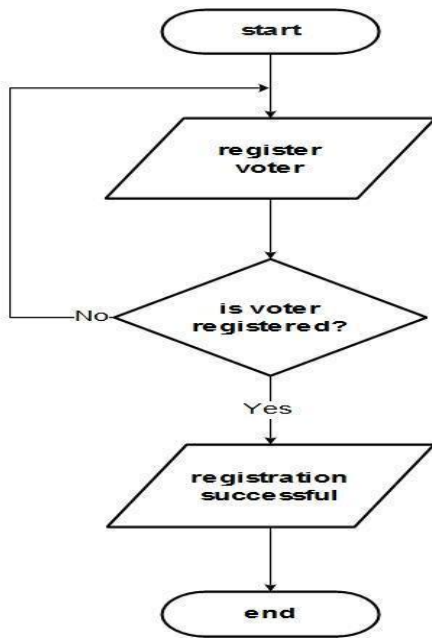

Methodology:

This is implemented with both software and hardware using different tools as

1) Software

a) Keil Tools by arm version 4

b) MATLAB

2) Hardware

a) Finger print module

b) ARM processor

c) Web camera

ADVANTAGES AND DISADVANTAGES:

Advantages

- Cost effective
- This system allows only authenticated voting than the existing equipment as the person is identified based on his Fingerprint and Face Recognition which is unique to each individual.
- Low power consumption
- It is economical
- Less manpower required
- Time conscious, less time required for voting & counting
- Avoids invalid voting as it prevents unregistered voters from voting.

RESULT ANALYSIS:

.In this figure as you can see that the finger print scanner and web camera are attach with the AVR microcontroller and LCD .We used LCD for the display purpose. We used five templates for the experimental purpose.

Model of Proposed System



The final experimental result in which person is giving his or her vote using biometric system and that templates match with the previously stored templates and the person can vote. And second time that person trying to give vote with the wrong fingerprint and face identification that indicates the fake voting and the siren blow. So this way we can completely overcome the problem of bogus voting.

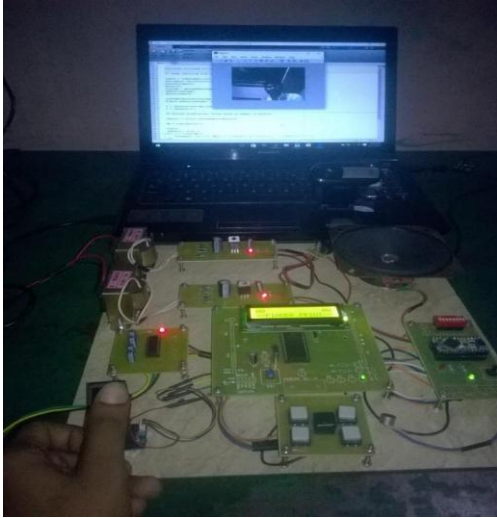

Working of proposed system

#### Disadvantages:

- Before voting the user has to enroll first.
- Sensitivity of finger print module causes sometimes Combine character error.

#### APPLICATIONS:

This project can be used as a voting machine to prevent rigging, during the elections in the polling booths.

- Fast track voting which could be used in small scale elections, like resident welfare association, "Panchayat" level election and other society level elections, where results can be instantaneous.
- It could also be used to conduct opinion polls during annual shareholders meeting.

- It could also be used to conduct general assembly elections where number of candidates are less than or equal to eight in the current situation, on a small scale basis.

#### CONCLUSION:

The project "SMART VOTING MACHINE based on finger prints and face recognition" was mainly intended to develop a fingerprint and face recognition based advanced Electronic Voting Machine (EVM) which helps in free and fair way of conducting elections which are basis for democratic country like India.

#### REFERENCES:

- [1] Umang Shah, Trupt Shah, Marteen Kansagara, Saagar Daxini, „Biometric Secured Voting Machine to Avoid Bogus Voting Based on AADHAR CARD“ , International Journal of Innovative Research in Computer and Communication Engineering , Vol. 3, Issue 3, March 2015
- [2] Rudrappa B. Gujanatti, Shivaram N. Tolanur, Murughendra S. Nemaoud, Shanta S. Reddy, Sangameshwar Neelagund, " A Finger Print based Voting System" , International Journal of Engineering Research & Technology (IJERT), ISSN: 2278-0181. Vol. 4 Issue 05, May-2015
- [3] M.Sudhakar, B.Divya Soundarya Sai, " Biometric System Based Electronic Voting Machine Using Arm9 Microcontroller,, IOSR Journal of Electronics and Communication Engineering (IOSR-JECE) e-ISSN: 2278-2834,p- ISSN: 2278-8735. Volume 10, Issue 1, Ver. II (Jan - Feb. 2015)"
- [4] Soumyajit Chakraborty, Siddhartha Mukherjee, Bhaswati Sadhukhan, Kazi Tanvi Yasmin, " Biometric Voting System using Aadhar Card in India ,, International Journal of Innovative Research in Computer and Communication Engineering (An ISO 3297: 2007 Certified Organization) Vol. 4, Issue 4, April 2016 '.