

# Smart Urban Street Lighting with IoT-Based Fault Localization

<sup>[1]</sup> M. Kalaivanan, <sup>[2]</sup> G. Manikannan, <sup>[3]</sup> Dr. R. Nithya, <sup>[4]</sup> P. Prabakaran  
<sup>[1][2][3][4]</sup> Department of Electronics & Communication Engineering,  
C.K. College of Engineering & Technology, Cuddalore, Tamil Nadu, India

*Abstract— Light is recognized as a fundamental form of energy that ought to be a primary focus in our daily experiences. There exists a profound connection between humans and light, and it is acknowledged that the integration of the Internet of Things (IoT) has the potential to amplify overall efficiency while significantly reducing costs. Through the incorporation of IoT technology, faults in street lights can be detected effortlessly, facilitated by the employment of two Light Dependent Resistors (LDR) sensors. This innovative approach allows one sensor to ascertain ambient light by monitoring prevailing weather conditions, thereby enabling automatic adjustments to the brightness of street lights. The implication of this technology is a substantial reduction in manual labor and a minimization of inconvenience to the general populace.*

*In instances where a street light malfunctions, it is designed to alert the relevant authorities using a Python Kivy application, thereby streamlining the resolution process for both the public and the authorities involved. This procedure is further refined through the use of an additional sensor dedicated to identifying malfunctions directly within the street lights. The inclusion of the WiFi module ESP232 plays a critical role in this system, as it is responsible for the transmission of pertinent data to the routers. Accessibility to this data is achieved through the Python Kivy application, which is instrumental in notifying the authorities regarding street light issues and pinpointing the exact location of the malfunction. Through this meticulously designed system, the efficiency of addressing street light malfunctions is significantly improved.*

## I. INTRODUCTION

The current method of maintaining the lighting grid is characterized by staff being required to conduct regular patrols with faulty lamps, a process that can extend over days or even months to complete. Additionally, reliance is placed on the community to report any dysfunctional streetlights.

The use of an automatic street lighting system that detects faults would eliminate wasted time and errors in the detection and reporting of malfunctions. Faults would be automatically detected by sensors within seconds of occurring, allowing technicians to be quickly directed to and repair the faulty light, significantly reducing the maintenance time required and saving up to 42% in maintenance costs.

The implementation of an automatic street lighting maintenance system could also simplify the process for municipalities to expand the street lighting system into additional areas and enhance the availability of streetlights in underserved communities. Moreover, the rapid detection and repair of faulty lights are expected to greatly enhance safety conditions for both vehicles and pedestrians.



**Figure 1:** Wifi Module ESP32

In our daily lives, linemen are tasked with manually setting the fault work. This arrangement can be problematic for the people residing on the streets, as they must inform the linemen of any issues. Additionally, the lights remain on from 6 PM to 6 AM, resulting in substantial power loss. To tackle these challenges, a solution based on IoT technology is proposed. This project aims to conserve energy by utilizing LDR to adjust lighting according to weather conditions and to detect faults, thus minimizing the need for manual inspections.

The cost efficiency of the implemented solution has been successfully demonstrated through an analysis of its performance relative to the associated expenses. An

automated system has been developed to activate and deactivate the lights based on real-time weather conditions. This optimization of energy usage not only responds to environmental changes but also contributes to overall efficiency and cost savings.

Street lighting fulfills a pivotal role in ensuring safety, security, and visibility in both urban and rural areas. Yet, the current approach to managing street lights is predominantly reliant on manual intervention for fault resolution and operation, which introduces inefficiencies, safety hazards, and increased costs. The prevalent use of High-Intensity Discharge (HID) lights in urban road lighting systems further compounds these challenges, given their limited controllability and requirements for manual operation.

This dependence on outdated technologies and manual processes impedes operational efficiency and fails to adapt to dynamic environmental factors like changing weather conditions. Consequently, there is an emerging need for a more automated, intelligent, and sustainable solution to mitigate these issues and enhance the overall management and performance of street lighting systems. This project is dedicated to exploring innovative technologies and methodologies to revolutionize the management of street lights, improve energy efficiency, and secure safer and more sustainable urban environments.

## II. LITERATURE SURVEY

Tang was designed to minimize the impact of street lights using the Arduino AT89S52. The project involves various technologies including LCD, digital clock, timer, and photosensitive induction. Its main goal is to automatically turn on when a vehicle passes by and turn off when it's not needed. Additionally, it is equipped with an auto alarm to detect faulty lights and provide information.

Anila Devi designed an automatic remote control system for a high-efficiency intelligent street lighting system using ZIGBEE network technology for devices and sensors. Additionally, she incorporated wireless communication for maintenance purposes and sensor control. The project utilizes LED lighting from solar panels.

Priyasree and Radhi designed a complete system of LED street lighting. This system disconnects the lighting during peak load times and reduces power consumption. They equipped each light with a segment that indicates its status, making it easy to identify any faults.

Subramanyam designed a wireless street lighting system that incorporates new emerging technologies, making it easily maintainable, cost-efficient, and, most importantly, energy-saving. He utilized solar panels for the lamp posts and LDR for power saving. Additionally, he developed a GUI application to monitor the status of the lights.

Silang and Xudean designed a wired sensor network to monitor the status of street lights. They took into account the latitude and longitude of the location, as well as the weather

report including sunrise and sunset times. They controlled the light intensity using LDR and monitored the temperature using a humidity sensor to automatically adjust the street lights.

Budhike Lothar designed a lighting system with two main components: a control module and a data processing module. He designed the system to operate and control light intensity, and most importantly, to turn street lights on and off. He controlled and maintained it through a web browser.

P. Nitya worked on improving streetlight automation by focusing on wireless communication for better performance. She aimed to send data to a central station using Zigbee wireless communication. This enables easy usability, energy efficiency, and additional energy savings.

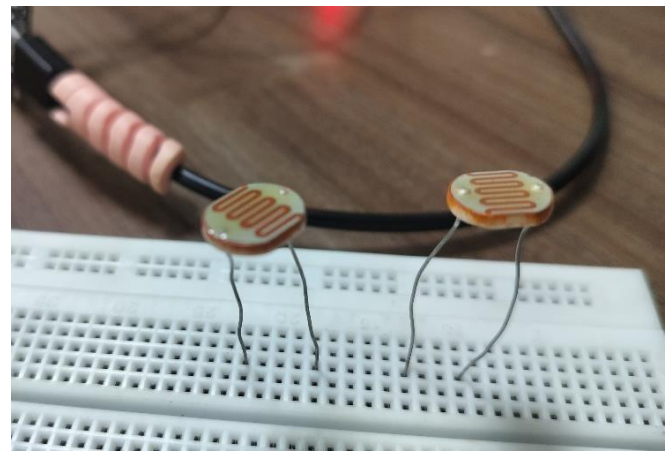

**Figure 2:** Light Dependent Resistors

Srikanth developed a project utilizing the technology of the ZigBee remote control street light system. His innovative system not only helps in saving energy but also in detecting faulty lights, which in turn reduces maintenance time and increases the lifespan of the street lights.

So-Young Hwang developed an innovative automatic remote monitoring system utilizing ZIGBEE network technology. This system enables real-time monitoring by leveraging JMF and Java's extension API, providing valuable functionality in the current context.

Ashok Kumar Nanduri, Siva Kumar Kotamraju, and G L Sravanthi designed a street light that automatically switches on and off using an LDR sensor. They made it capable of detecting the intensity of the light and adjusting accordingly based on weather conditions, reducing energy consumption and cost. This innovation is useful for the next generation.

N. Sravani, Y. Latha, and G. Nirmala collaboratively developed a sophisticated street light fault detection system utilizing Lora technology. They designed this innovative system to effectively identify faults in street lights, particularly when they are not operational. The system, equipped with a Light Dependent Resistor (LDR), detects the fault and triggers a notification mechanism to alert the appropriate authorities, ensuring prompt maintenance and repair of the faulty street lights.

C. Sunitha Ram, Challa Naveen Kumar, Sompalli Abhilash This project involves the design and implementation of an automated street light control system and an underground drainage monitoring system using GSM technology. Additionally, it has the capability to monitor the condition of manhole lids. Its key advantages include minimal upkeep requirements and cost-effectiveness. The system offers real-time monitoring of both street lights and manholes, with the ability to alert officials via text messages.

Annareddy Sravani, P.Malarvezhi, R. Dayana designed an Automating street lights is a modern necessity, with dimming capabilities based on traffic and time via sensors like LDR and PIR. Communication between Raspberry Pi and Arduino enhances functionality, while current and voltage sensors optimize energy usage. This system not only reduces costs and electricity wastage but also offers efficient fault detection and remote monitoring, making it a cost-effective and sustainable solution for smart urban lighting.

Khorgade, Jaiswal, Karmore, and Kamble devised an intelligent lighting system capable of efficiently managing street lights through sensor-based dimming and brightening as needed. This IoT-based system aims to decrease road accidents and conserve significant amounts of power and electricity while enhancing safety and operational efficiency. Moreover, it ensures a secure nighttime environment for pedestrians by illuminating the surroundings.

Rani, Pradeepa, Shab designed In the current scenario, faulty street lights can lead to accidents and increase crime rates. However, the system offers automated fault detection in street lights, reducing the time for detection and rectification. This eliminates the need for frequent manual inspections by electrical inspectors, saving time and effort. By leveraging Internet of Things (IoT) technology, the system can automatically detect and update the status of faulty street lights in real time, improving overall detection and rectification efficiency.

Sirisha, Sankula designed the automatic street lighting system to effectively address energy wastage by efficiently monitoring and controlling street lights, utilizing sensors for fault detection and brightness adjustment. Integrated with IoT, the system promptly alerts authorities about malfunctions and enhances security through digital cameras. The hardware implementation and validated results ensure the system's effectiveness and reliability in optimizing energy usage and improving overall street lighting management.

T M D Darsan designed critical sectors like hospitals and banking, ensuring a reliable power supply is paramount. The proposed IoT-based system manages power continuity by swiftly rerouting power during faults, detected via notification signals. The faulty line is isolated for repair while the system guides repair teams to the exact location, ensuring efficient restoration of the power supply. This IoT system guarantees power supply continuity, making it ideal for smart city initiatives.

### III. EXISTING SOLUTION

The existing solution for managing street lights relies heavily on manual intervention for fault resolution, leading to inconvenience and potential safety hazards. Inconvenience and potential safety hazards are caused by manual intervention for fault resolution in the existing solution for managing street lights. This manual approach also incurs significant costs, making it unsustainable in the long run. Significant costs are incurred by this manual approach, making it unsustainable in the long run.

In both rural and urban areas, street lights play a crucial role in ensuring the safety and well-being of residents. The safety and well-being of residents are ensured by street lights playing a crucial role in both rural and urban areas. However, the manual management of these lights presents numerous challenges and requires considerable effort from maintenance personnel. Numerous challenges are presented by the manual management of these lights, requiring considerable effort from maintenance personnel.

Currently, the prevalent solution utilizes High-Intensity Discharge (HID) lights, commonly found in urban road lighting systems. High-Intensity Discharge (HID) lights, commonly found in urban road lighting systems, are utilized as the prevalent solution. HID lights operate based on gas discharge principles, making it challenging to control their power output through voltage reduction methods due to the nature of the discharge process. Their power output control through voltage reduction methods is challenging due to the nature of the discharge process based on gas discharge principles.

One major drawback of this system is the manual operation required to turn the lights on and off, which ideally should be automated and adjusted based on prevailing weather conditions. The manual operation required to turn the lights on and off, which ideally should be automated and adjusted based on prevailing weather conditions, is one major drawback of this system.

### IV. PROPOSED SOLUTION

The innovative project involves utilizing advanced technology to enhance the efficiency and functionality of street lighting systems. Advanced technology is leveraged to ensure that street lighting systems operate more efficiently and effectively. Light Dependent Resistor (LDR) sensors are integrated into the system, serving dual purposes. One LDR sensor is strategically positioned to detect ambient light levels, allowing for the dynamic adjustment of street lamp intensity to ensure optimal lighting conditions at all times. This feature contributes not only to energy conservation but also to enhanced visibility and safety for pedestrians and motorists.

Furthermore, another LDR sensor is dedicated to monitoring the operational status of street lamps and detecting any faults or irregularities in their functionality.

The proactive fault detection capability of the system enables swift identification of issues, leading to timely maintenance and reduced downtime. By addressing faults promptly, a reliable and efficient street lighting infrastructure is maintained, minimizing disruptions and ensuring continuous service.

To effectively manage and process the data collected from these LDR sensors has been implemented as the central control unit of the system. Sensor inputs are processed in real time by the microcontroller, and crucial information is communicated to a Firebase database via a WiFi module (esp32). This data transmission capability allows for centralized data storage, analysis, and remote monitoring, enabling informed decisions regarding maintenance schedules and resource allocation to be made by authorities.

Furthermore, to empower users with convenient access to system information and control capabilities, a user-friendly Python Kivy application has been developed. This application serves as a comprehensive dashboard where users can monitor the status of street lamps, receive instant fault alerts, and remotely adjust lighting parameters as needed. By providing a seamless user interface, the application enhances operational efficiency and facilitates proactive management of street lighting assets.

Overall, the innovative solution aims to revolutionize street lighting management by integrating smart technologies that optimize energy usage, improve reliability, and reduce maintenance costs. By automating processes and enabling proactive fault detection, the system contributes to creating safer, more sustainable, and technologically advanced urban environments.

## V. METHODOLOGY

In the current project, Light Dependent Resistor (LDR) sensors have been meticulously integrated to cater to various functionalities. One of the LDR sensors has been strategically positioned to detect ambient light levels, enabling the system to dynamically adjust the lamp's intensity to ensure optimal lighting conditions. Another LDR sensor should be added to detect faults in the street light and monitor irregularities in the lamp to improve energy efficiency and minimize costs.

To effectively manage and control these sensor inputs, the ESP32 microcontroller has been employed due to its versatility and reliability. The microcontroller not only processes the data obtained from the sensors but also facilitates the transmission of this information to a Firebase database using a WiFi module, specifically the ESP32. This sophisticated data handling system allows for seamless storage and retrieval of information, laying the foundation for in-depth analysis and proactive monitoring.

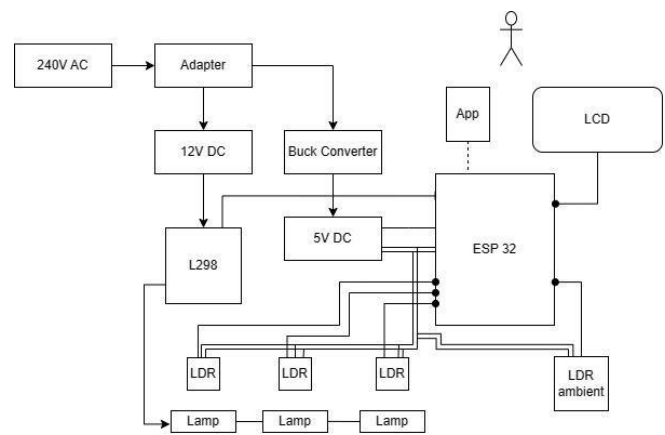

Figure 3: Block Diagram

Furthermore, to ensure that the collected data is presented to end users in a highly accessible and user-friendly manner, a Python Kivy application has been meticulously developed. Through this application, users can conveniently access and review detailed system information, empowering them to make informed decisions swiftly and effectively.

The overarching goal of this system is to optimize operations, minimize the need for manual intervention, and reduce costs. Additionally, it aims to bolster efficiency by autonomously adjusting the lamp's behavior based on real-time environmental conditions, thereby mitigating inadvertent misuse and maximizing energy efficiency.

The methodology for implementing the streetlight fault detection system involves a systematic approach to ensure its successful deployment and functionality. Initially, a comprehensive requirement analysis is conducted to understand the specific needs of the system, including real-time fault detection, remote monitoring capabilities, and the ability to adjust brightness levels based on ambient light conditions.

Next, the integration of Light Dependent Resistors (LDR) sensors into the streetlight infrastructure is crucial. These sensors are responsible for detecting faults in individual streetlights and monitoring the surrounding light intensity. The hardware setup includes microcontrollers like ESP32, LDR sensors, and communication modules such as WiFi or GSM/GPRS, enabling data collection and transmission between the sensors and the central monitoring system.

On the software front, a robust software solution is developed using appropriate programming languages like Python for backend operations and HTML/CSS/JavaScript for frontend interfaces. The software processes the data collected by the sensors, identifies faults, and controls the brightness levels of the streetlights based on predefined thresholds.

Establishing IoT connectivity is another essential aspect of the methodology. This involves creating a network that allows seamless communication between the streetlights, sensors, and the central monitoring system. IoT connectivity enables real-time data exchange, remote monitoring, and

management of the streetlight system.



**Figure 4: LED Strip**

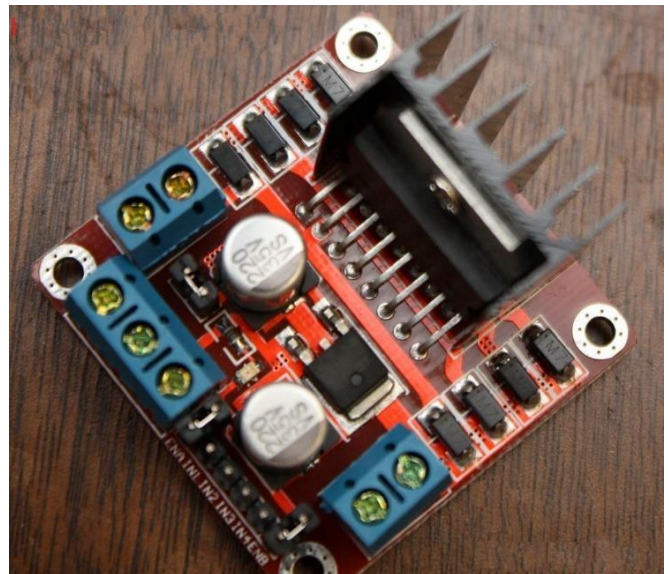

**Figure 5: L298**

Additionally, a user-friendly mobile application is developed for Android and iOS platforms. This application serves as a vital tool for maintenance personnel, providing them with fault notifications, system status updates, and the ability to remotely adjust the brightness levels of the streetlights.

The methodology also includes rigorous testing and validation procedures to ensure the reliability, accuracy, and responsiveness of the system. Once tested and validated, the system is deployed in real-world settings, and continuous monitoring is carried out to address any issues that may arise and implement improvements as needed. Overall, this comprehensive methodology ensures the successful implementation and functionality of the streetlight fault detection system using IoT technology, contributing to improved operational efficiency and sustainable urban development.

1. Fault detection (LED alert): This system utilizes LED indicators to promptly notify maintenance teams of any faults or malfunctions in street lighting infrastructure. LED alerts are visible and can provide immediate visual cues, ensuring swift response and efficient resolution of issues to maintain uninterrupted lighting.
2. Fault detection (App alert - IoT): Leveraging Internet of Things (IoT) technology, the system enhances fault detection by sending real-time alerts to designated personnel via a dedicated mobile application. This IoT-enabled alert system ensures quick notification and allows for remote monitoring and troubleshooting, enhancing overall maintenance efficiency.

3. Intensity Control by PWM(L298): The system employs Pulse Width Modulation (PWM) to control the brightness and intensity of street lights. PWM offers precise control over the light output, allowing for efficient energy usage and customization based on environmental conditions and requirements.
4. Working with ESP32: Integrated with ESP32 technology, the system establishes reliable communication and operation within the network. ESP32 enables seamless connectivity, data exchange, and control functionalities, enhancing the overall performance and responsiveness of the system.
5. App Creation: A user-friendly mobile application is developed to provide stakeholders with easy access to monitor, manage, and control street light operations. The app offers features such as real-time status updates, fault alerts, remote adjustments, and data analytics, improving operational efficiency and decision-making.
6. Firebase Connectivity for Real-time Data: By integrating with Firebase, the system ensures real-time data storage, retrieval, and analysis. Firebase connectivity enables centralized data management, facilitating informed decision-making, performance monitoring, and maintenance scheduling based on real-time insights.
7. Location Feeding by GPS: Incorporating GPS technology, the system accurately tracks and records the location of street lights. GPS-based location feeding allows for precise monitoring, maintenance planning, and efficient navigation for maintenance teams, ensuring timely response and optimization of resources.

## VI. RESULT

The result illustrates that consequently controlling the on/off work of a framework improves proficiency and diminishes costs, eventually contributing to the general

well-being of people. Also, it's worth noticing that the Light Subordinate Resistor (LDR) serves a double reason: firstly, by measuring. By coordination LDR sensors, the venture quickly distinguishes flawed streetlights and alters light concentrated based on encompassing conditions.

A user-friendly portable app streamlines upkeep by informing the workforce of issues and empowering inaccessible brightness control. This IoT-driven arrangement optimizes vitality utilization and improves open security in urban areas. Ambient light is concentrated, and faults inside the system.

Light is a vital portion of day-by-day lives, directing us and guaranteeing security. The Web of Things (IoT) revolutionizes networks by interfacing ordinary objects to the Web, encouraging information trade, and improving operational productivity.

This venture utilizes IoT principles to address streetlight faults. By utilizing Light Subordinate Resistors (LDR) sensors, quickly distinguishing failing streetlights. These sensors not as it were identify deficiencies but moreover alter light concentrated based on surrounding lighting conditions, optimizing vitality usage.

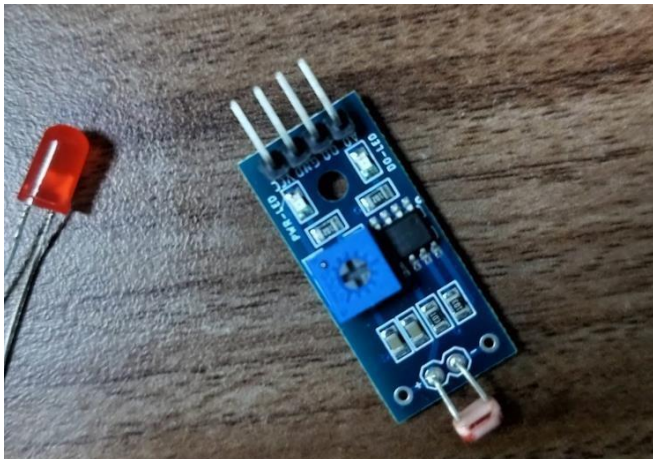

**Figure 6: LDR Module**

Additionally, arranged to make a user-friendly mobile application that will act as a central administration platform. The app will caution the support workforce of any detected issues with streetlights, streamlining the troubleshooting handle. In addition, clients will be able to remotely control the brightness of streetlights through the app, contributing to vitality preservation endeavors and guaranteeing more secure urban environments. In outline, this activity utilizes IoT innovation to make strides in streetlight administration, advance vitality productivity, and upgrade general open security.

## VII. CONCLUSION

In conclusion, the utilization of IoT innovation in streetlight fault discovery extends marks a critical leap forward in urban infrastructure management. The seamless

integration of Light Dependent Resistors (LDR) sensors permits quick detection of malfunctioning streetlights and dynamic adjustment of light intensity based on environmental factors.

Furthermore, the development of a user-friendly mobile application serves as a centralized platform for managing streetlight issues. The app's capability to inform maintenance personnel of identified deficiencies and enable remote brightness control improves operational efficiency and contributes to energy conservation efforts.

By harnessing the power of IoT, the project not only addresses the immediate need for effective streetlight management but also sets a precedent for sustainable urban development. The ability to optimize energy usage while ensuring public safety underscores the transformative impact of innovative technologies in enhancing the quality of life in urban environments.

Leveraging IoT innovation for streetlight fault discovery and management represents a significant advancement in urban infrastructure optimization. The integration of Light Dependent Resistors (LDR) sensors enables precise fault identification and dynamic light intensity adjustments, promoting energy efficiency. The mobile application streamlines maintenance operations by providing real-time fault notifications and remote brightness control, enhancing overall operational effectiveness.

This initiative not only improves streetlight functionality but also sets a precedent for sustainable urban development practices by leveraging innovative technology solutions to address critical infrastructure challenges and enhance public safety, ultimately contributing to a more livable and efficient urban environment.

## REFERENCE

- [1] Tang "Design of Multi-functional Road Light Control Framework Based on AT89S52 Single-chip Microcomputer" Hengyu Wu, Minli Tang, IEEE, 2010.
- [2] Anila Devi Y, V. Jaya Prakash, "GSM Based Farther Control Framework of High-Efficiency Brilliantly Road Lighting Framework Utilizing A Zigbee Organize of Gadgets and Sensor" Universal Diary of Science and Investigate (IJSR) P.P 2319- 7064.
- [3] Silang and Xudean, "Plan of modern shrewd road light control framework," IEEE ICCA 2010, Xiamen, 2010, pp. 1423-1427.
- [4] Budhike Lothar, "Plan of multi-functional road light control framework based on AT89S52 single-chip microcomputer," The 2nd Universal Conference on Mechanical Mechatronics and Robotization, Wuhan, 2010, pp. 134-137. DOI: 10.1109/ICINDMA.2010.5538068.
- [5] P. Nithya, "An unused streetlight checking framework based on remote sensor systems," The 2nd Worldwide Conference on Data Science and Designing, Hangzhou, 2010, pp. 6394-6397. DOI: 10.1109/ICISE.2010.5691530.
- [6] Priyasree, Radhi & H Kauser, Rafiya & E, vinitha & Gangatharan, N. (2012). "Automatic Road Light Concentrated Control and Street Security Module Utilizing

- Inserted System,” Universal Conference on Computing and Control Building (ICCCE 2012), At Coimbatore Organized of Data Innovation, 2012.
- [7] Srikanth, "Realtime versatile road lighting framework", Environment and Electrical Building (EEEIC) 2012 11th Worldwide Conference on, pp. 958-961, 2012. 8. So-Young, "Vehicle and person on foot mindful road lighting computerization," 2015 IEEE 13th Universal Conference on Mechanical Informatics (INDIN), Cambridge, 2015, pp. 1269-1274,2015
- [8] B.K.Subramayam, plan, and advancement of brilliantly remote road light control and observing framework along with GUI, / Universal Diary of Building Inquire about and Applications (IJERA),2019
- [9] Ashok Kumar Nandri," IoT-based Programmed Harmed Road Light Blame Discovery Administration System”, Worldwide Diary of Progressed Computer Science and Applications, 2020.
- [10] Sravani, Y. Latha, G. Nirmala, Road Light Controlling and Observing of Blame Location utilizing LoRa, Universal Diary for Advanced Patterns in Science and Technology,2021
- [11] C. Sunitha Ram, Challa Naveen Kumar, Sompalli Abhilash “Automated street light control and manhole monitoring with fault detection & reporting system for municipal Department”, International Journal of Scientific Research in Engineering and Management (ijsrem),2023
- [12] Annareddy Sravani, P.Malarvezhi, R. Dayana, Design and implementation of dimmer-based smart street lighting system using Raspberry Pi and IoT, International Journal of Engineering & Technology, 7 (2.8) (2018) 524-528
- [13] Khorgade, Jaiswal, Karmore, and Kamble, Smart Street Light, International Journal of Advanced Research in Science, Communication and Technology,2021
- [14] Rani, Pradeepa, Shab “Measurement and fault detection in the intelligent wireless system using wireless devices”, International Conference on Cryptography, Security and Privacy,2016
- [15] Sirisha, Sankula, “Automatic Street Lightning System with PIR”, World Journal of Advanced Research and Reviews-2019
- [16] T M D Darsan,” Fault Detection Using IoT in Essential Power Transmission Lines”, 2023 Intelligent Computing and Control for Engineering and Business Systems (ICCEBS),2023.