

Smart traction on solar powered space rovers by small host controllers

ANJU.K

Ece Department,
Hindusthan College Of Engineering & Technology
Coimbatore, India.
Sararenju143@Gmail.Com

JOSHUA DANIEL

Assistant Professor, Eee Department
Hindusthan College Of Engineering And Technology
Coimbatore, India.
Renjujosemj@Gmail.Com

Abstract—Space robots come in many shapes and sizes. Planetary rovers explore the surface of moons and planets, taking photos and soil samples and sending the data back to labs on Earth. Orbital robots, a relatively new type, service orbiting satellites or assemble parts of a space structure. Based on these developed sensor systems, various approaches related to this work can be grouped into two categories. The first one tends to use infrared sensors for their simple implementation and fast obstacle detection, but they show great accuracy and reliability limits when it comes to detect obstacles having a complicated shape. On the other hand, the slope detector helps to figure out the reliability of the present path. We have the specially designed wheel system, which can be avoid traps on the path.

Index Terms—electromechanical system , hostile space, space rover, topographic mapping techniques, infrared sensors.

I. INTRODUCTION

A robot[1] is a virtual or mechanical artificial agent. In practice, it is usually an electromechanical machine which is guided by computer or electronic programming, and is thus able to do tasks on its own. Another common characteristic is that by its appearance or movements, a robot often conveys a sense that it has intent or agency of its own.

Robots have a physical moving structure, a motor, a sensor system, a power supply, and a processor. Despite the vast diversity of robot designs and implementations, all robots possess one similarity: they all have a movable mechanical body.

Like the human body, robot needs manipulators which act as joints for it to move and become more flexible and versatile. Manipulators are constructed of series of joints and links. Joints provide relative motion between the input link and the output link and each joint provides the robot a specific degree of freedom.

Actuator spins wheels and causes the joints to pivot. In a mechanical sense, actuators are frequently used

as mechanisms to introduce or prevent motion. Actuator comes in different forms.

Some robots use electric motors, solenoids, hydraulic system, or pneumatic system. Generally wired electrically, the actuators cause the joints to move.

The controller gives the robots instructions on what tasks to do. Controllers generally house the programs and protocols needed by robots to function properly. Microcontrollers have gained popularity among robotics engineers and programmers primarily because of its compact, small size, and ease in programming and re-programming. Part of controllers is the sensors and processors. A controller manages the data going to and from the main memory, typically a processor or a microprocessor.

All robots have power supplies. The power supply, as the name suggests, is the source of power. It is a device or a system that supplies electrical or other types of energy to a load or a group of loads called the PSU. Among the popular power supplies are the 120 and 240 volts AC supplied by a utility company, batteries, chemical fuel cells, solar power, and generators and alternators. The robot's power supply is the same as the human heart. It supplies power to all parts of the robot even the joints and the most minute elements.

II. EXISTING SYSTEM

Mars Exploration Rovers

Two rovers, Spirit and Opportunity, were landed on Mars as part of the Mars Exploration Rover mission[2]. Both Spirit and Opportunity have been operating on Mars since January 2004. By March 19, 2009, Opportunity had traversed 15 kilometers on the Martian surface. Spirit, mission designation MER-A (Mars Exploration Rover - A), is the first of the two rovers of NASA's ongoing Mars Exploration Rover Mission. It landed successfully on Mars.

It is on 04:35 Ground UTC on January 4, 2004, three weeks before its twin, Opportunity (MER-B), landed on the other side of the planet.

The rover completed its planned 90-sol mission. Aided by cleaning events that resulted in higher power from its solar panels, Spirit went on to function effectively over twenty times longer than NASA planners expected following mission completion. Spirit also logged about 10 kilometers of driving instead of the planned 1 km, allowing more extensive geological analysis of Martian rocks and planetary surface features. Initial scientific results from the first phase of the mission (the 90-sol prime mission) were published in a special issue of the journal Science.

III. PROPOSED WORK

Space robots come in many shapes and sizes. Planetary rovers explore the surface of moons and planets, taking photos and soil samples and sending the data back to labs on Earth. Orbital robots, [3] a relatively new type, service orbiting satellites or assemble parts of a space structure. The Japan Aerospace Exploration Agency (JAXA), the U.S. Defense Advanced Research Projects Agency, and other organizations are experimenting with orbiting prototypes. And probes are landing on asteroids.

For an autonomous mobile space robot performing a navigation-based task in a vague environment, to detect and to avoid encountered obstacle's and not get into the sand are important issues and a key function for the robot body safety as well as for the task continuity. Obstacle detection and avoidance in a real world environment - that appears so easy to humans - is a rather difficult task for autonomous mobile robots and is still a well-researched topic in robotics.

This project is basic stage of any sand trap automatic obstacle avoidance robot. This ROBOT has sufficient intelligence to cover the maximum area of provided space. It has infrared sensors which are used to sense the obstacles coming in between the path of ROBOT. It will move in a particular direction and avoid the obstacle which is coming in its path. Also with design of its wheel it can easily moves on sands and avoid traps.

On other side the steep slopes is a major threat and a in a sand terrain form an added probability of getting struck. Hence we use an effective slope detection mechanism and algorithm to identify and avoid dangerous slopes. The distance detector used for this system is of sonar type. The detector is mounted on a arm at a specific angle that helps the accurate calculation of slope

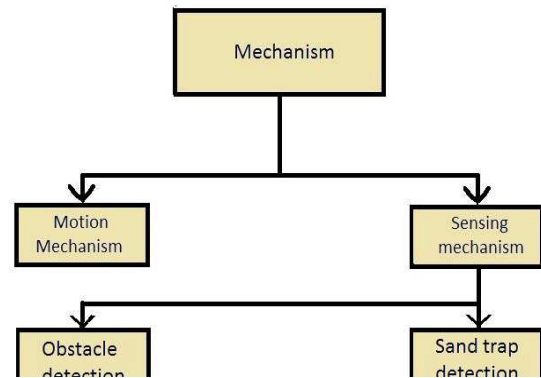

Figure1 Types of Mechanism

In many previous works, a wide range of sensors and various methods for detecting and avoiding obstacles and traps for mobile space robot purpose have been proposed. Good references related to the developed sensor systems and proposed simplified detection and avoidance algorithms can be done easily.

Based on these developed sensor systems, various approaches related to this work can be grouped into two categories. The first one tends to use infrared sensors for their simple implementation and fast obstacle detection, but they show great accuracy and reliability limits when it comes to detect obstacles having a complicated shape. On the other hand, the slope detector helps to figure out the reliability of the present path. We have the specially designed wheel system, which can be avoid traps on the path.

To map its environment before it sets out it uses a cutting-edge technique called 2-D simultaneous localization and mapping. The robot uses these two types of sensors to detect possible danger of its surroundings by measuring the dimensions of the topography within a range of few meters. It builds a two-dimensional map by two point mechanism. The path followed from the starting point is tracked down to estimate the current position. Once the current position is calculated it determines the direction and distance of the destination.

However, since the horizontal IR sensor [4] slit, are sensing in only one direction, which is insufficient to know the presence of obstacles standing on the robot's path. The main improvement brought to this detection method is to change the meeting point of the IR beam projector, in other words to scan our sensor throughout all the mobile robot front environment by providing three sensors in a row to detect one end. Therefore, scanning horizontally IR sensor slits throughout the robot front environment and capturing and checking constantly the image's left region would enable a robot equipped with such sensor to detect quickly and efficiently

any obstacle present in its front neighborhood. With these inputs the actuator will run the robot by controlling motor actions.

We will develop the notation and a mathematical model for the kinematics of wheeled mobile robots and discuss the main issues for control. Mobile robots for operation on flat terrain have several simplifying features that make them easier to model than space robot. Here through this designated wheel it can be move on all hard and soft terrain. Also avoids the traps on space. For these we are controlling each wheel independently.

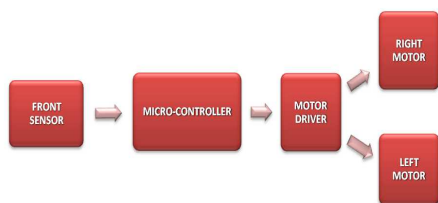

Figure2; Motion Mechanism

IV. SIMULATION MODEL

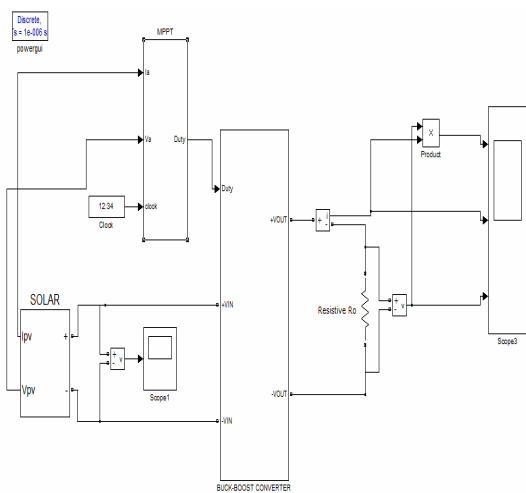

Figure3 Simulation model

Traditional solar inverters perform MPPT for an entire array as a whole. In such systems the same current, dictated by the inverter, flows through all panels in the string. Because different panels have different IV curves and

different MPPs (due to manufacturing tolerance, partial shading, etc.) this architecture means some panels will be performing below their MPP, resulting in the loss of energy.

Some companies are now placing peak power point converters into individual panels, allowing each to operate at peak efficiency despite uneven shading, soiling or electrical mismatch.

At night, an off-grid PV power system[5]–[8] uses batteries to supply its loads. Although the battery pack voltage when fully charged may be close to the PV array's peak power point, this is unlikely to be true at sunrise when the battery is partially discharged. Charging may begin at a voltage considerably below the array peak power point, and a MPPT can resolve this mismatch.

When the batteries in an off-grid system are full and PV production exceeds local loads, a MPPT can no longer operate the array at its peak power point as the excess power has nowhere to go. The MPPT must then shift the array operating point away from the peak power point until production exactly matches demand. (An alternative approach commonly used in spacecraft is to divert surplus PV power into a resistive load, allowing the array to operate continuously at its peak power point.)

In a grid-tied photovoltaic system,[9] the grid is forced to absorb all power delivered from solar systems. The MPPT in a grid tied PV system will always operate the array at its peak power point.

The current sweep method uses a sweep waveform for the PV array current such that the I-V characteristic of the PV array is obtained and updated at fixed time intervals.

BUCK BOOST CONVERTER

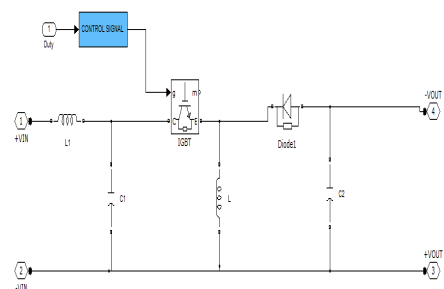

Figure4:

Buck Boost Converter

The buck–boost converter is a type of DC-to-DC converter that has an output voltage magnitude that is either greater than or less than the input voltage magnitude.

Two different topologies are called *buck-boost converter*. Both of them can produce a range of output voltages, from an output voltage much larger (in absolute magnitude) than the input voltage, down to almost zero.

The output voltage is of the opposite polarity as the input. This is a switched-mode power supply with a similar circuit topology to the boost converter and the buck converter. The output voltage is adjustable based on the duty cycle of the switching transistor. One possible drawback of this converter is that the switch does not have a terminal at ground; this complicates the driving circuitry. Neither drawback is of any consequence if the power supply is isolated from the load circuit (if, for example, the supply is a battery) as the supply and diode polarity can simply be reversed. The switch can be on either the ground side or the supply side.

Principle Of Operation

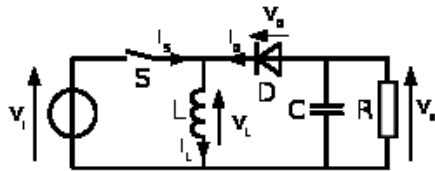

Figure5: Schematic of Buck Boost Converter

While in the On-state, the input voltage source is directly connected to the inductor (L). This results in accumulating energy in L. In this stage, the capacitor supplies energy to the output load.

While in the Off-state, the inductor is connected to the output load and capacitor, so energy is transferred from L to C and R. polarity of the output voltage is opposite to that of the input.

The output voltage can vary continuously from 0 to (for an ideal converter). The output voltage ranges for a buck and a boost converter are respectively 0 to and to .

When the switch is then opened, the inductor will be cut off from the input voltage supply, so the current will tend to drop to zero. Again, the inductor will fight such an abrupt change in current. To do so, it must now act like a voltage source to the rest of the circuit, which it can do using the energy it stored while charging. Since current was previously flowing "down" the inductor, it will want to maintain this direction, and so the voltage that it provides will be inverted relative to input supply. During this time, the inductor will discharge through the load and the rest of the circuit, which will cause its voltage to decrease over time. Also during this time, the capacitor in parallel with the load will charge up to the voltage presented by the inductor.

When the switch is once again closed, the diode is forward biased by the input supply, cutting the load off from the left hand side of the circuit. During this time, the capacitor will discharge[10] into the load, providing energy and voltage to it. By cycling the switch fast enough, the inductor can be allowed to charge and discharge only slightly in each cycle, maintaining a relatively steady voltage to the load. Similarly, the capacitor will only need to discharge slightly while the switch is open before it has a chance to recharge again while the switch is closed

V.SIMULATION RESULTS

Power output

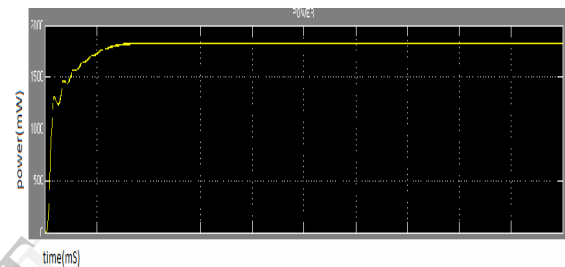

Current output

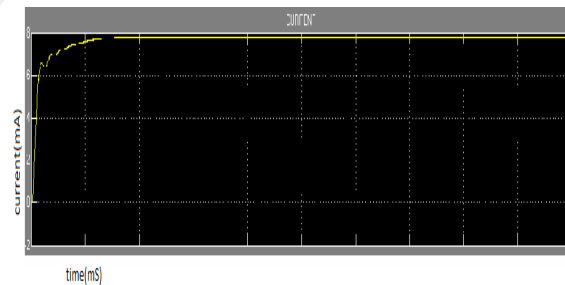

Voltage output:

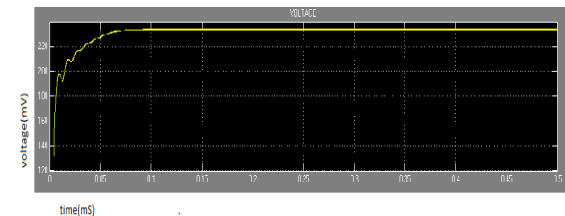

Figure6: Output waveforms

VI.CONCLUSION AND RESULT

The proposed work deals with a real time obstacle detection and avoidance method by an autonomous Rover using an active Ultrasonic distance sensor, weather monitoring and underground cable detection After detailing the detection strategy and implementation of the developed sensor with the Rover, the solar energy is converted to electrical energy and output is taken in terms of current, voltage and power. The work includes confirmed the originality of our approach with results of an obstacle avoidance equipment in an indoor corridor.

Simulation is done using MATLAB. The solar panels consist of photovoltaic cells. The input to the solar panels are irradiation and temperature. It is given as input to the photovoltaic model. Voltage and current parameters are taken as the output. By dropping the current across resistor the voltage is taken as output. One duty cycle is generated using maximum power point tracker. Voltage, current and clock signal are given as input to the maximum power point tracker. The buck boost converter consists of one insulation gate bipolar transistor and diode. One duty cycle is given as control signal to insulation gate bipolar transistor. Two capacitors and inductors are connected in parallel to the IGBT and diode. In buck boost converter if load is increased voltage is increased and if load is decreased voltage is decreased. Voltage and current are taken as the output and product of voltage and current that is power is taken as third output.

REFERENCES

- [1] L. T. D'Angelo, S. Weber, Y. Honda, T. Thiel, 2008, "*New planetary rovers for long range Mars science and sample return*", IEEE Transactions on robotics.
- [2] Y. Rimet, Y. Brusquet, D. Ronayette, C. Dageville, M. Lubrano, E.,2007, "*Robust Algorithm for Real-Time Route Planning*," IEEE Transactions on aerospace and electronic systems."
- [3] A. Lymberis and D. Dittmar,2007 "*7 th sense-a multipurpose robot for military*,"IEEE Transactions on military robots.
- [4] M. F. Dempsey and B. Condon,2007 "*Inertial sensor based wireless control of a robotic arm*"IEEE Transactions on robotic parameters.
- [5] V. Gramse, A. De Groote, and M. Paiva,2006, "*Vision-based Cleaning Area Control for Cleaning Robots*" IEEE Transactions on robotics.
- [6] L. Faustini and G. Martini,2006 "*small host control for battery powered robotic vehicle*,"IEEE Transactions on mechnronics.
- [7] J. Witt, M. Schukar, K. Krebber, 2005, "*Image Recognition and Force Measurement Application in the Humanoid Robot Imitation*", IEEE Transactions on instrumentation and measurement

[8] F. Taylor,2003, "*The Detection and Following of Human Legs Through Inductive Approaches for a Mobile Robo with a Single Laser Range Finder*," IEEE Transactions on industrial electronics

[9] M. Di Rienzo, F. Rizzo, P. Meriggi, 2002, "*Observing And Control Of Agricultural Parameters By Using robotic Infrastructure*" IEEE Transactions on agricultural robots.

[10] M. Coyle, V. M. Inc, 2002, "*Robotic Platform for Monitoring underground Cable Systems*" IEEE Transaction on mechatronics