

Smart Mushroom Cultivation using IoT

Sampada Singh, Simran, Sneha Anand, Sushma S J
 Department of Electronics and Communication Engineering,
 GSSSIETW, Mysuru

Abstract – IoT system implementation in agricultural field is used widely for efficient farming solutions. The wireless network system for monitoring the real time data and a user interface and automation of the system is established using a dynamic website and also by teaching the machine learning to our IoT system to automate the process in this research. The major problem faced in the mushroom cultivation process is related to the irrigation, environmental parameter monitoring and reducing human intervention. The Raspberry pi model B+ is used as the brain of the system to which different Esp8266 nodes are communicating to update with the real time data. the dynamic website is acting as a user interface as well as our tool to automate the process. By using the technique used in this research all the problems can be overcome. For sensing the soil moisture content the Biosensors can be used for checking the presence of microbials can also be used for sensing the moisture content of the soil.

Keywords – IoT system, Sensing Node, Django, TensorFlow, My SQL, HTML, CSS, JS.

1. INTRODUCTION

Mushrooms are a separate group of organisms called Fungi. They don't have the green material chlorophyll present in them hence they grow on dead and decaying organic materials made from organic products mixed with gypsum. There is a thread like structure known as mycelium which absorbs the nutrients from the dead and decayed material on which the mushrooms are grown and penetrates the substratum. White Button mushrooms can be grown only half a year in climatic controlled conditions. Seasonal growing of mushrooms can be done for five to six months when the outside temperature is favourable for the crop.

Initially the mushroom bed (racks) will be placed in a dark room where the temperature, humidity and CO2 concentration of the room will be monitored continuously. These racks will be brought to these rooms via a movable conveyer belt system. If the moisture content of the bed varies from the desired requirement then drip irrigation system to supply the water is used. The amount of water supplied will be regulated by the battery-controlled solenoid valve. The solar panel (renewable source of energy)

gives power supply to the rechargeable battery which is connected to a solar charge regulator, which ensures that the battery connected to it is not overcharged. The turn on and off the battery is monitored by Raspberry pi 3 b+ as per the water requirement (solenoid valve open or close) and accordingly the power supply has to be given. Based on the different stages of mushroom cultivation different humidity and temperature requirement of the mushrooms the water

supply is given accordingly. The temperature, humidity and Carbon dioxide concentration of the room will be monitored using DHT11 Sensor & MG811 Sensor. The moisture content of the mushroom bed will be monitored using Soil Moisture Sensor. The real time data will be updated in the cloud every 15 Seconds.

According to the real time data the actuation of the increased temperature, humidity and the carbon dioxide concentration of the room & moisture content of the bed is done (if needed), which implies that the sensing node first reports the controller about the real time data and then as per the commands regulates it to required value.

A Dynamic website is built using Django which acts as our software tool for automating the whole process. Also, for reducing the human intervention for this whole process a conveyer belt system is designed which reduces the human intervention and maintains the hygienic environment in the factory.

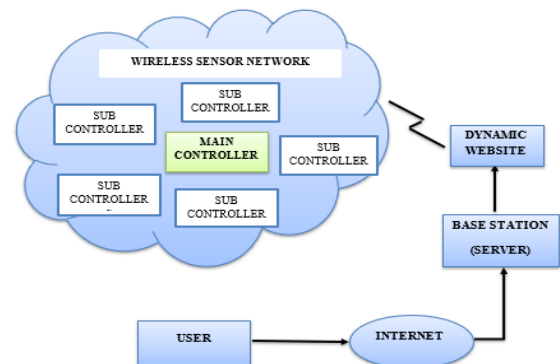

Fig 1: Overview of the System Used

1. SENSING NODE DEVELOPMENT

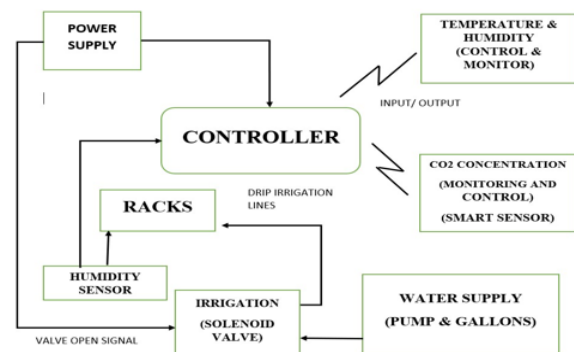

Fig 2: Sensing Node block diagram

The system above shows the sensing node block diagram which uses the ESP8266 as the controller which is monitoring the DHT11 Sensor, MG811 Sensor and soil moisture sensor and sending the data of these sensors to the cloud.



Fig3: Esp8266 controller

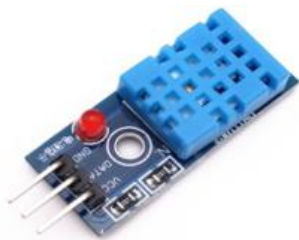

Fig 4: DHT11 Sensor



Fig 5: MG811 Sensor

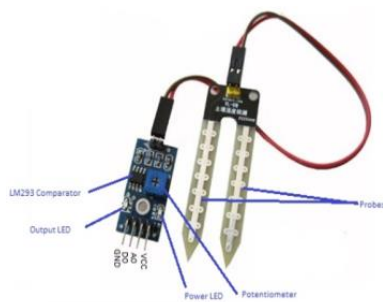

Fig 6: Soil Moisture sensor

The sensors are interfaced to the ESP8266 using the Vcc, Gnd and data pins (in case of DHT11 the digital output pin is connected and in case of soil moisture sensor the Analog Output pin is connected to the Esp8266), the ESP8266 stores the data to the cloud via Arduino IDE.

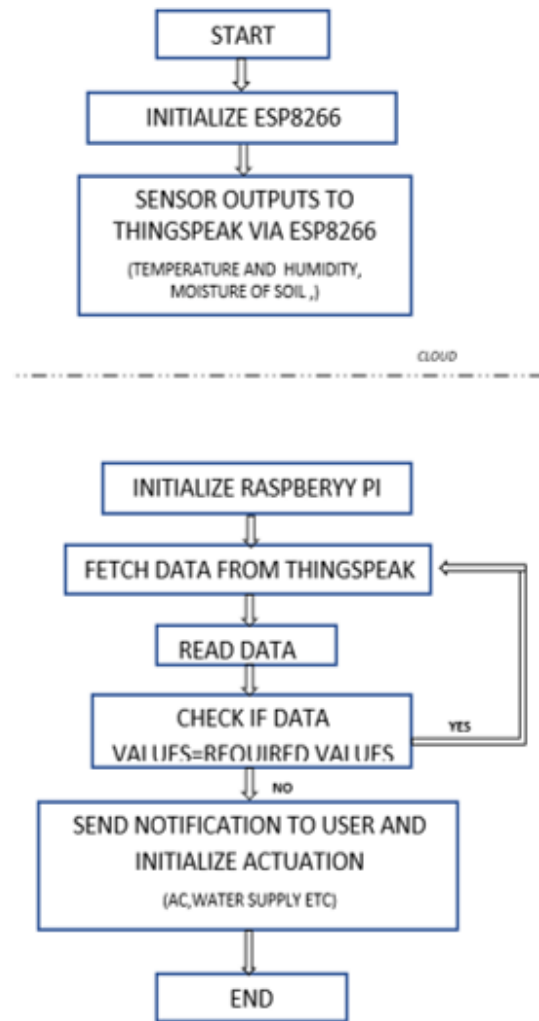

Fig7: Flow Diagram of the working of the sensing Node and Storing the value to the cloud.

This sensor node senses the data every 15 seconds and updates the same to the cloud and the cloud sends the same data to the controller and updates the real time data to the database every 15 seconds according to which the actuation process is carried out and the automation is done accordingly. The MG811 sensors measures the Carbon dioxide concentration. The voltage of the sensor and carbon dioxide concentration is inversely proportional.

Instead of the Soil Moisture sensors Biosensors can also be used which can also sense the presence of the microbials since mushrooms are very sensitive and get poisoned easily.

2. IoT SYSTEM DEVELOPMENT

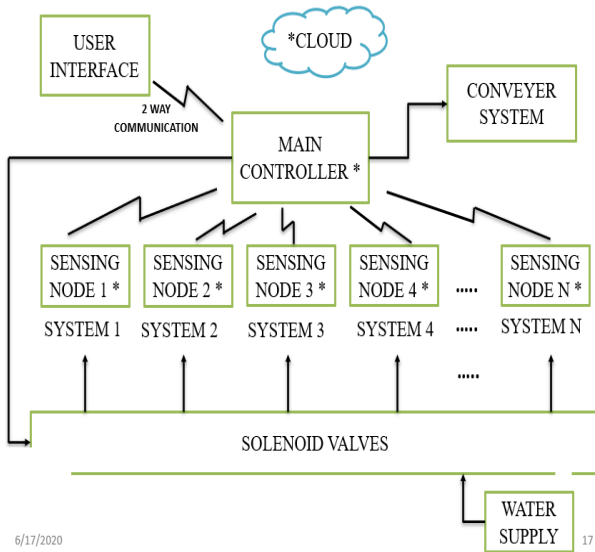

Fig 8: IoT system Block Diagram

The IoT system block diagram is shown in the figure above. the main controller is our Raspberry pi 3B+ controller module to which all the sensing nodes as in the ESP8266 are communicating for the actuation. The real time data status of each dark room where the mushrooms are grown is fetched to the main controller i.e. the brain of the system by the cloud. To each room solenoid valve connections are made for the Drip line irrigation System.

The Drip line irrigation system is used because mushrooms require a very less amount of water. the solenoid works in such a way that it turns on as soon as the control for opening the valves comes from the Relay Module. the solenoid opens and the water supply is given also it should be noted that every 15 seconds the moisture content of the bed is sensed and the data is given to the controller. Suppose the amount of water required by the mushroom bed is of value y it should be noted that in this research the solenoid is programmed in such a way that when the moisture content of the bed reaches the value of $y-2$ the solenoid must be turned off so that no excessive amount of water is being supplied to mushroom bed which can harm the crop.

The conveyer belt system is also controlled by the raspberry pi 3B+. the conveyer belt system is used to reduce the human intervention so that it can add up to automating the mushroom cultivation process.

The user interface connected to the Main controller is the Dynamic website which is designed to automate the process.



Fig9: Raspberry pi 3 B+ Module



Fig 10: 12V Solenoid Valve

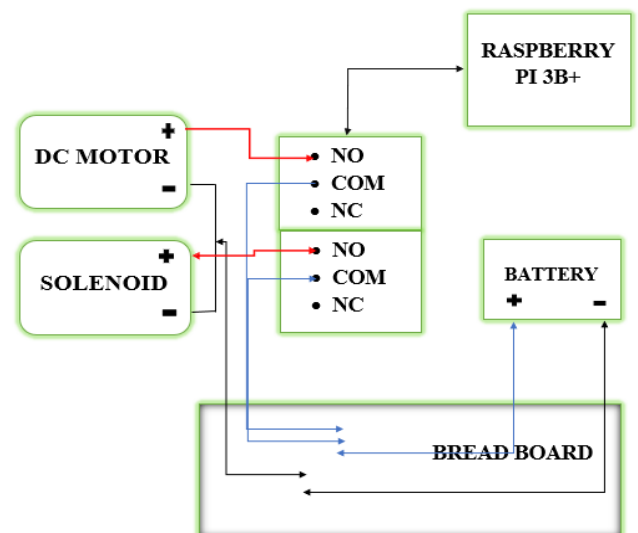

Fig 11: Circuit diagram for solenoid operation

3. DYNAMIC WEBSITE DEVELOPMENT

The Dynamic website designed for the system will act as a use interface to the system. Also, it will be the official website for the mushroom factory or the organisation which will have different interfaces such as customer interface, Employee interface and the Administrator interface.

This dynamic webpage is designed using the web designing technologies such as HTML, CSS & JS in the front end. In the backend the Database is designed using the My SQL technology. The Front end and the Back end is connected using the python web framework Django.

Figure 12 shows the working of the designed Dynamic website in this research.

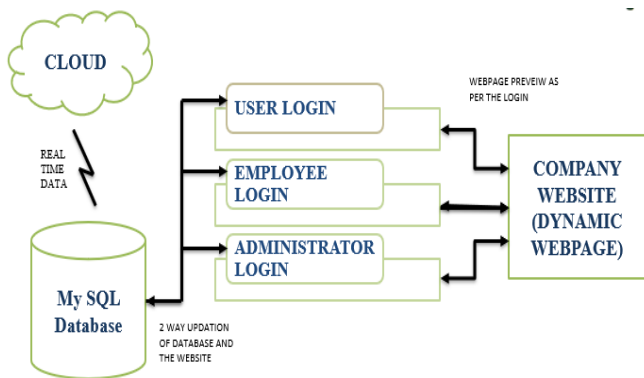

Fig 12: The block diagram showing the working principle of the Dynamic website of the system

The front which is designed using the HTML, CSS and JS is the direct user interface of the system, all the changes that will be happening in the system will be done according to the interface in this page.

There is a login option on this webpage which will have a Customer login, Employee Login and Administrator Login. This is what is the dynamic part. The Customer login is for the buyers for ordering the mushrooms, if a new Customer logs in he needs to register first so that he/she can perform the actions he wants. If an old customer logs in he can view his order status, order history etc., just like a E-commerce website. When any employee logs in he can see his work details, suppose a employee from a sales department logs in he can see the new order placed, revenue status, how many new customers joined, Account status etc., at the same place when a person from technical department logs into the site he can view the Status of the environmental parameters such as temperature, humidity, carbon dioxide concentration, moisture content of beds of each dark rooms separately where the mushrooms are grown and now suppose the moisture content of the bed is very low and he switches the water supply on the data will be updated to cloud and from the cloud it goes to the main controller as in the Raspberry pi

3B+ module and the solenoid and turned ON and the water supply is given. Similarly, when the temperature or the humidity rises the AC can be turned ON. Whereas when the Administrator logs in they can view the overall process of each department of the organization.

The real time data of the factory is in the cloud which is continuously being updated to the database. All the changes which are made in the website are also changed automatically in the database as in suppose a employee leaves the organisation and 2 new employees join the organization if in the front end we delete the login credential of the employee left and register the employee joined the organization the same will be updated to the database automatically.

4. THE CONVEYER BELT SYSTEM

The conveyer belt system will be used for laying the manure, these manures are the bed on which the mushrooms are grown. These manures are coming from pasteurization rooms and had to be laid into the rooms where the mushrooms had to be grown.

A conveyor belt isan very effective way of transporting for moving larger stuffs specially in industries. Mobility in conveyor belt systems is that it can autonomously move to the required direction.

The use of the conveyer belt system, which rotates horizontally as well as vertically will reduce the human effort and hence reducing the human intervention will lead in growing the mushrooms in a hygienic way.

Conveyor belt in the mushroom factory will be used with inclination, which will allow mushroom beds to be moved from one elevation to another easily. They can be loaded and unloaded for any number of times also eliminating the human intervention.

Figure 13 shows the flow diagram of working of the conveyer belt system.

Speed of the conveyer belts can be controlled while the mushroom beds are moved over it which avoids the falling of the mushroom beds and the beds can be systemically placed in the required dark room where the mushrooms are grown

REFERENCES

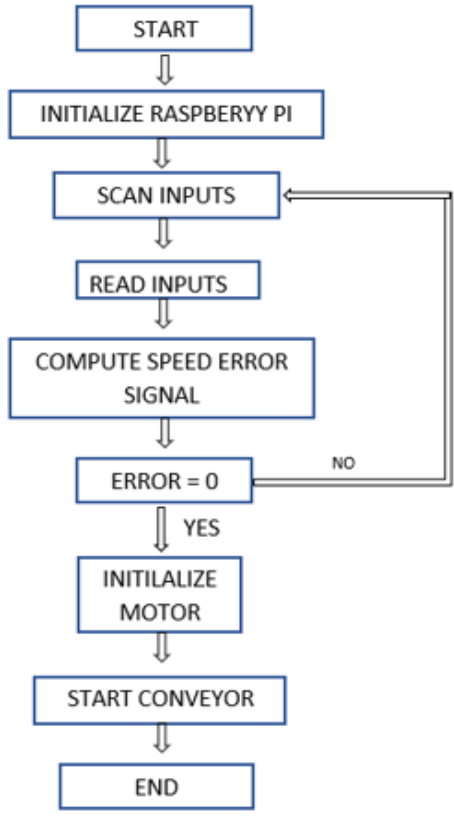

Fig 13: flow diagram of working of the conveyor belt system

CONCLUSION

The temperature monitoring & controlling and water supply problems related to the mushroom cultivation will be solved in a effective way by the above approach and its implementation. Mushrooms require a perfect moisture level to grow. Thus, by maintaining the perfect moisture requirement of the bed will ensure the proper growth of button mushrooms and also prevents the growth of unwanted fungi.

By the implementation of the conveyer belt system the human intervention will be less and the proper hygiene is maintained in mushroom cultivation process. The Dynamic System will make the whole system a smart system by automating it.

ACKNOWLEDGEMENT

The work described in this paper was partly supported by IETE, Mysuru, Shan Mushrooms and the Government of Karnataka.

The authors would also like to thank GSSSIETW, Mysuru for letting us conduct this project.

- [1] Arjuna Marzuki and Soh Yan Ying , “Environmental monitoring and controlling system for mushroom farm with online interface”, School of Electrical and Electronic Engineering, University Sains Malaysia, Penang, Malaysia (Aug 2017)
- [2] Theeramet Kaewwiset, Paitoon Yodkhad, “Automatic Temperature and Humidity control system by using Fuzzy Logic Algorithm for Mushroom nursery”, IEEE (2017)
- [3] IoT for All, "IoT Applications in Agriculture" (January 2018) (<https://www.iotforall.com/iot-applications-in-agriculture/>)
- [4] Decision support system for Precision Agriculture.(2015) (https://www.youtube.com/watch?v=q0FnMD2_0Fw)
- [5] Cultivation of White Button Mushroom (Agaricus bisporus) - Directorate of Mushroom Research, Solan (<https://www.youtube.com/watch?v=T8LrW-AFq9g&t=119s>)
- [6] Mohd Saiful Azimi Mahmud, Salinda Buyamin, Musa Mohd Mokji, M. S. Zainal Abidin, “IoT based smart environmental monitoring of mushroom cultivation”, University Teknologi Malaysia, Skudai Johor, Malaysia,2016
- [7] Guoping Zhou, Yanan Chen “The Research of Carbon Dioxide Gas Monitoring Platform based on the Wireless Sensor Networks” Information Department, Nanjing Forestry University , Nanjing, Jiangsu, China.(2011)
- [8] Mohammed H. Al- Obaidi and Kasim M. Al- Aubidy, “Wireless Sensor Network Based Real-Time Monitoring and Control for Factory Automation” Intelligent & Embedded Systems Research Group, Faculty of Engineering, Philadelphia University, Jordan (2018)
- [9] Daniel Zinca1, “Experiments with protocol framework in IoT ” Communications Department, Technical University of Cluj-Napoca, Romania(2016)
- [10] Nikhil Agrawal, Smita Singhal, “Smart Drip Irrigation System using Raspberry pi and Arduino ” Engineering Manager, Siemens, Noida, ASET, Amity University, Noida 2015
- [11] Parvati Bhandari, Megha Kimothi M. “IOT Based Design Implementation of Mushroom Farm Monitoring Using Arduino Microcontrollers& Sensors”, Dept. of Wireless Mobile Communication Engg, GRD IMT, Dehradun, India. (May 2018)
- [12] Igbafe Orikumhi, Tarik Abdul Rahman “An Overview of Internet of Things (IoT) and Data Analytics in Agriculture: Benefits and Challenges” (2018)
- [13] Gourab Panda , Tufan Saha “Building of Low Cost Reliable Wireless Sensor Network for Smart Indoor Agriculture Products”
- [14] Md Ashifuddin Mondal , Zeenat Rehenat “IoT Based Intelligent Agriculture Field Monitoring System” Mar 2011
- [15] “International Journal of Engineering & Technology” Intelligent Mushroom Monitoring System 2018
- [16] Prof. Rashmi Jain, Shaunak Kulkarni, Ahtesham Shaikh, Akash Sood. “Automatic irrigation system for agriculture field using wireless sensor network (WSN)” Dr. D. Y. Patil Institute of Engineering and Technology, Pimpri, Pune (2016)
- [17] Mrs. Vaishali Puranik, Mrs. Sharmila, Mr. Ankit Ranjan, Ms. Anamika Kumari “Automation in Agriculture and IoT” Computer Science And Engineering ,Krishna Engineering College ,Ghaziabad, India(2019)
- [18] Anushree Math, Layak Ali, Pruthviraj U, “Development of Smart Drip Irrigation System Using IoT” Central University of Karnataka Kalaburagi , India (2018)
- [19] “International Journal of Computer Science & Information Technology”, Environmental Monitoring And Controlling System For Mushroom Farm With Online Interface, 2017
- [20] Kavianand G, Nivas V M, Kiruthika R, Lalitha S, “Smart Drip Irrigation System for sustainable Agriculture” Panimalar Engineering College, Chennai, India.(2016)
- [21] Mr. Rakesh Palandurker and Prof. Ritesh Banpurkar “Design And Analysis Of Conceptual Mobile Belt Conveyor Material Handling System”, International Conference on Innovation and Research in Engineering, Science & Technology Held on 23rd & 24th February 2018, Organized by Tulsiramji Gaikwad Patil College of Engineering & Technology, Nagpur, 441108, Maharashtra, India.
- [22] Ms. Sayali Todkar, PG Student, Prof. Milind Ramgir, Associate Professor, JSPMs RSCOE Tathwade “Design of Belt Conveyor System”, International Journal of Science, Engineering and Technology Research (IJSETR)