

# Smart Grid System using PV Model with MPPT using Fuzzy Logic Controller for Voltage and Frequency Regulation

<sup>1</sup>A. Anbumani

<sup>1</sup>PG Scholar, Department of EEE,  
Arasu Engineering College,

<sup>2</sup>Dr. C. Venkatesan

<sup>2</sup>Asso.Professor and Head, Department of EEE, Arasu  
Engineering College, Kumbakonam,

**Abstract** – In this paper presents voltage and frequency regulations in a grid connected solar PV systems using SEPIC Converter with Fuzzy Logic Controller (FLC). This method allows effective control over active and reactive power available from the grid to PV system and vice-versa. A SEPIC converter is used to improve the performance of the system and also increasing the efficiency in better manner. The PV plant and the battery storage are integrated with the grid with the help of dc-dc and dc-ac converters in such a way that bi-directional flow of active and reactive powers can be achieved. When up regulation is occurred energy is transferring from PV to grid for regulate the voltage. Similarly, when down regulation is occurred energy transferring from grid to PV for regulate the frequency. The performance of the proposed FLC-based MPPT operation of SEPIC converter is compared to that of the conventional proportional–integral (PI)-based SEPIC converter is more efficient. Controllers integrating energy sources respond to the received signals and attempt to fulfill the grid demand. The system response is almost instantaneous and thus can be very helpful in frequency and voltage regulation.

**Keywords-** Solar array; MPPT; SEPIC converter; Three phase inverter; Fuzzy Logic Controller; Voltage Regulation.

## I INTRODUCTION

Renewable sources of energy acquire growing importance due to its enormous consumption and exhaustion of fossil fuel. Also, solar energy is the most readily available source of energy and it is free. Moreover, solar energy is the best among all the renewable energy sources since, it is non-polluting. Energy storage systems are promising technologies which may work in conjunction with PV systems to regulate frequency and voltage [1]. Energy supplied by the sun in one hour is equal to the amount of energy required by the human in one year. Photo voltaic

arrays are used in many applications such as water pumping, street lighting in rural town, battery charging and grid connected PV systems. As known from a Power-Voltage curve of a solar panel, there is an optimum operating point such that the PV delivers the maximum possible power to the load. The optimum operating point changes with solar irradiation and cell temperature.

The purpose is situated to design and optimize a SEPIC dc/dc converter (Single Ended Primary Inductance Converter).The SEPIC converter allows a range of dc voltage to be adjusted to maintain a constant voltage output. This job talks about the importance of dc-dc converters and why SEPIC converters are used instead of other dc-dc converters. From this project, one learns dc-dc converter optimization and control. The most efficient method of regulating voltage through a circuit is with a dc-dc converter.

There are five main types of dc-dc converters. SEPIC converters are one of the simplest form of DC/DC converters which operates on voltage lift technique. It allows controlled energy transfer from unregulated source to regulated output voltage [4].The imprecision of the weather variations that can be reflected by PV arrays can be addressed accurately using a fuzzy controller. the advantages of the fuzzy logic algorithm, the MPPT algorithm is integrated with the FLC so that the overall control system can always provide maximum power transfer from the PV array to the inverter side, in spite of the unpredictable weather conditions.This paper presents an FLC-based MPPT operation of the SEPIC converter for PV inverter applications As the proposed method always transfers maximum power from PV arrays to the inverter side, it optimizes the number of PV modules.

## II PROPOSED SYSTEM

The proposed work comprises of a photovoltaic exhibit, dc/dc converter with an inverter, intended for accomplishing the MPPT control with Incremental Conductance (InCond) calculation.

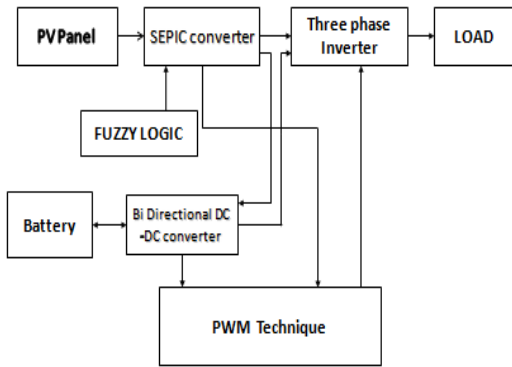

Fig. 1: Block diagram of Proposed System

In this model, though the information sources are the sun powered illumination and cell temperature, the yields are the photovoltaic voltage and current. At the point when the PV framework with a MPPT is associated with the power electronics converters (PEC), a programmed input controller will be expected to adjust the power and keep up the immediate voltage consistent particularly when the framework is running under different conditions. In three phase inverter electronic switch utilized is MOSFET as it can deal with extensive power, which is appropriate for this nearby planetary group. The PWM inverter yield waveform is then shifted to deliver a sinusoidal AC waveform.

**2.1 INCREMENTAL CONDUCTANCE MPPT**

In incremental conductance method the array terminal voltage is always adjusted according to the MPP voltage it is based on the incremental and instantaneous conductance of the PV module [3].

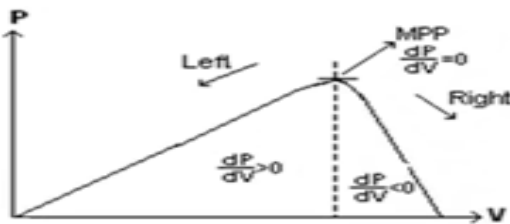

Fig. 2: Basic idea of incremental conductance method on a P-V Curve of solar module

The slope of the P-V array power curve is zero at the MPP, increasing on the left of the MPP and decreasing on the Right hand side of the MPP. The PV system is modeled using Power System Block set under Matlab/Simulink.

**2.2 PV EQUIVALENT CIRCUIT**

Photovoltaic (PV) is a method of converting solar energy into direct current electricity using semiconducting materials that exhibit the photovoltaic effect. The change of voltage level fed to the inverter is the main function of the dc-dc converter. In this paper, the voltage level increases

or decreases[2]. Solar cells are connected in series and parallel to set up the solar array. Solar cell will produce dc voltage when it is exposed to sunlight. the equivalent circuit model for a solar cell. Its generated current depends on the characteristic of material, age of solar cell, irradiation and cell temperature.

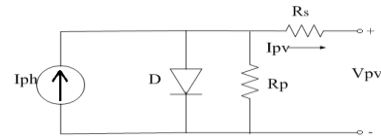

Fig. 3: Equivalent Circuit

Current  $I_{ph}$  is a direct function of irradiance and temperature and the diode exhibits the cell’s p-n junction characteristics. To build a 2 kW array, five panels are connected in series in order to reach the desired voltage ( $26.3 \times 5 = 131.5$  V), and two such strings are connected in parallel to deliver the desired amount of current ( $7.6 \times 2 = 15.2$  A) [1]. Energy storage systems are promising technologies which may work in conjunction with PV systems to regulate frequency and voltage.

**2.3 THREE PHASE VOLTAGE SOURCE INVERTERS**

Inverters are commonly used for medium voltage applications. For high-voltage high-power applications, the inverter also serves as a control mechanism for the reactive power and voltage stabilization. The output voltage can be varied by varying the input dc voltage and keeping constant inverter gain, however, if the input dc voltage is fixed and cannot be controlled, the gain of the inverter has to be varied to obtain variable output voltage. Varying the gain of the inverter is mainly done by a scheme which is known as Pulse Width Modulation (PWM). The inverter gain is basically the ratio of ac output voltage to the dc input voltage. Based on the power supply, inverters can be broadly classified into two types: Voltage Source Inverter and Current Source Inverter. A VSI has small or negligible impedance at its input terminal that is, it has a stiff dc voltage source.

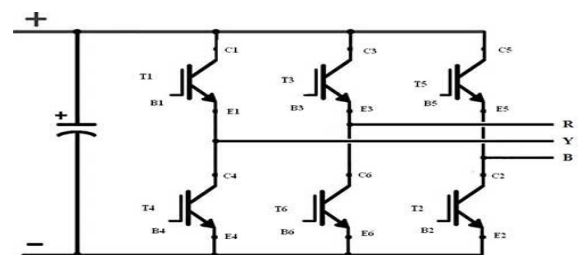

Fig. 4: Three phase inverter

### 2.4 FLC Algorithm

In FLC design, one should identify the main control variables and determine the sets that describe the values of each linguistic variable [2]. The input variables of the FLC are the output voltage error  $e(n)$  and the their is change of this error  $e_{-}(n)$ . The output of the FLC is the duty cycle of  $d(n)$  of the PWM signal, which regulates the output voltage. The triangular membership functions are used for the FLC for easier computation. A five-term fuzzy set, i.e., negative big (N-II), negative small (N-I), zero (Z), Positive small (P-I), and positive big (P-II), is defined to describe each linguistic variable.

Fuzzy logic expressed operational laws in linguistics terms instead of mathematical equations. Many systems are too complex to model accurately, even with complex mathematical equations; therefore traditional methods become infeasible in these systems. However fuzzy logics linguistic terms provide a feasible method for defining the operational characteristics of such system. Fuzzy logic controller can be considered as a special class of symbolic controller.

The fuzzy logic controller has three main components

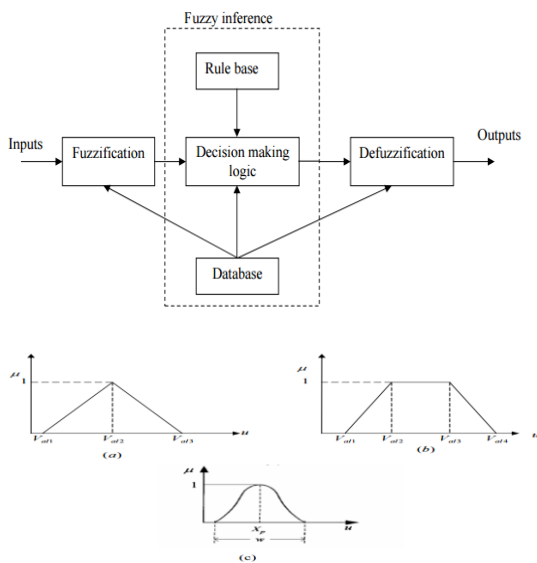

Fig. 5: (a) Triangle, (b) Trapezoid, and (c) Bell membership functions.

The inputs of the fuzzy controller are expressed in several linguist levels. As shown in Fig.4.3 these levels can be described as Positive big (PB), Positive medium (PM), Positive small (PS) Negative small (NS), Negative medium (NM), Negative big (NB) or in other levels. Each level is described by fuzzy set.

### 2.5 DC-DC POWER CONVERTER

DC-DC converters can be used as switching mode regulators to convert an unregulated dc voltage to a regulated dc output voltage. The regulation is normally achieved by PWM at a fixed frequency and the switching device is generally BJT, MOSFET or IGBT.

There are several different types of dc-dc converters, buck, boost, buck-boost,cuk topologies, have been developed and reported in the literature to meet variety of application specific demands. The important requirement of any DC-DC converter used in the MPPT scheme is that it should have a low input current ripple.

The purpose is situated to design and optimize a SEPIC dc/dc converter (Single Ended Primary Inductance Converter).The SEPIC converter allows a range of dc voltage to be adjusted to maintain a constant voltage output. This job talks about the importance of dc-dc converters and why SEPIC converters are used instead of other dc-dc converters. This undertaking also goes into detail about how to control the output of the converter with either a potentiometer or feedback to show how it can be implemented in a circuit. From this project, one learns dc-dc converter optimization and control.Circuits run best with a steady and specific input. Controlling the input to specific sub-circuits is crucial for fulfilling design requirements.

### III SIMULATION RESULTS

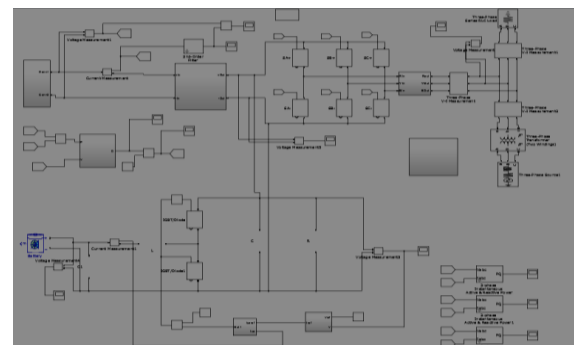

Fig. 6: Overall Simulation Diagram

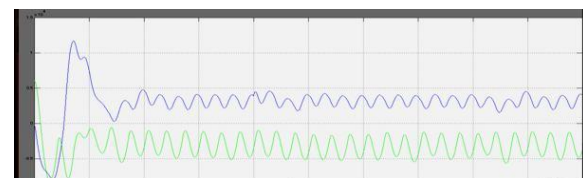

Fig. 7: Active and Reactive power

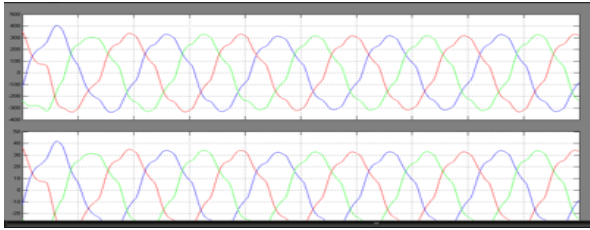

Fig. 8: Output Voltage and Current Waveform

Table 1: System Parameter Details

Components	Value
Solar panel	20 Watts,12 Volts,1.3Ah
MOSFET	IRF510
Inductor	1mH
Capacitor	1000 $\mu$ F/50V
Diode	1N4148
Microcontroller	dsPIC30F2010
Swithcing Frequency	1 kHz

#### IV CONCLUSION

A new technique to implement frequency and voltage regulation capability in solar photovoltaic power plant in the framework of the Smart Grid is discussed. This method allows effective control over active and reactive power available from the system. A system comprising of a 20 W PV array, 12V battery with bi-directional dc-dc converter, three phase inverter and the grid was modeled, and simulated in MATLAB. A battery increases the reliability and flexibility of the system. Results show that based on the commanded signal, the PV plant can respond quickly and can participate in regulation. The control techniques adopted are simple, autonomous and easy to implement. The most important factor in regulation is the size of the system. Since the simulation looks promising, the next step is to check its feasibility on hardware and to incorporate other energy storage options as well.

#### REFERENCES

- [1] Ravi Bhatt, *Student Member IEEE* and Badrul Chowdhury, *Senior Member IEEE* “Grid Frequency and Voltage Support using PV Systems with Energy Storage.”
- [2] Anusuya.V1, Vishnupraba.G2, PG Scholar, Bannari Amman Institute of Technology, India1,2 MPPT using Fuzzy Logic Controller for SEPIC converter and three phase inverter, International Journal of Advanced Research in Computer and Communication Engineering, Vol. 4, Issue 4, April 2015.
- [3] M.Lokanadham,PG Student Dept. of Electrical & Electronics Engineering Sri Venkatesa Perumal College of Engg & Tech K.Vijaya Bhaskar,Asst. Professor Dept. of Electrical & Electronics Engineering Sri Venkatesa Perumal College of Engg & Tech, Incremental Conductance Based Maximum Power Point Tracking (MPPT) for Photovoltaic System, International Journal of Engineering Research and Applications (IJERA) ISSN: 2248-9622 www.ijera.com Vol. 2, Issue 2,Mar-Apr 2012.
- [4] S.Ravivarman1, T.Samydurai2, “Optimized Grid Power Injection with Maximum Power Point Tracking using Cascaded SEPIC Converter and Three Phase Inverter”, Assistant Professor, Dept. of EEE, K.S.Rangasamy College of Technology, Trichencode, Tamilnadu, India, PG Student [PED], Dept. of EEE, K.S.Rangasamy College of Technology, Trichencode, Tamilnadu, India International conference, Vol. 4, Issue 1, January 2015.