

# Smart Grid System for Water Pumping and Domestic Application using Arduino Controller

R. Priyanka, S. Vinitha, D. Yalini, R.  
Yamuna Electrical and Electronics  
Engineering. K.Ramakrishnan College of  
technology, Trichy, Tamilnadu, India.

R. Jai Ganesh  
Assistant Professor, Electrical and Electronics  
Engineering.  
K.Ramakrishnan College of technology,  
Trichy, Tamilnadu, India.

**Abstract**—In current scenarios, many water pumping systems are available using solar PV, windmill, and diesel power. This paper suggest hybrid source (i.e.) combination of solar & wind energy, since solar & wind provides better performance and reliability. The main objective of this system is to pump the water automatically depends on moisture content and in inoperative condition the hybrid source will be used for the domestic application. This process will execute based on automatic control mechanism using arduino controller. In addition this methodology satisfies the domestic power demands and it pays the way for automation in the field of irrigations.

**Keywords** – Hybrid source, Water pumping system, automation, Arduino controller, moisture sensor.

## I. INTRODUCTION

The consumption of electricity during the year 2014 was 881,562GWh, which is drastically increased at the rate of 938,823GWh in the year 2015. As the consumption rate of electrical energy which keeps on increasing. From the above scenario, our future generation will firmly face a huge electricity demand. We are in a right time to ameliorate this issue. From the analysis we have done on some of the sectors such as domestic agriculture and commercial we came to an conclusion that agriculture sups more power rather than other sectors at the range of 18.19% in 2014 which is raised to 19.21% in 2015. Within this one year the energy devoured is extended in agriculture, which is the backbone of our Indian economy. So there is a need in technology development in agriculture sector which provides

employment for rural people. Even though the technologies are leading ahead in one hand, the rural areas are undeveloped in some sorts of problem such as power demand, lack of man power, power cut off. To overcome all these issues we are proposing an idea which be useful to meet a demand in both agriculture field and domestic sector, by the mode of automatic irrigation and to store energy apart from duration of irrigation which is used for domestic purpose by using hybrid source. We combined both wind and solar as our hybrid source because of its reliability, pollution free and open source of availability. By sensing the moisture content in the field, the control signal is generated in the arduino controller, depending on the control signal the controller manages the pumping system and alternatively the power from the hybrid source is conserved for domestic application by connecting it to the grid or by storing in a battery. Disadvantages of the existing system is listed out below

- Mainly focused on irrigation.
- Used only for single purpose.
- When the motor is in off condition the energy is wasted

In order to overcome the disadvantages of the existing system, some of the advantages of proposed systemis pointed out below,

- It focuses on irrigation as well as for domestic purpose.
- Dual purpose application.

- When the motor is in off condition the surplus monitored. The process of supplying

The fig. 1.1 shows the block diagram representation of proposed system.

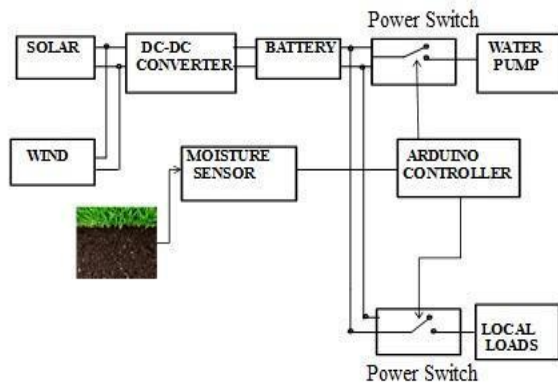

Figure 1.1: Block diagram of proposed system

**A. HYBRID SYSTEM:**

Hybrid is an alternative approach to producing clean, non-polluting energy from two of the most abundant renewable energy sources. Our system uses a hybrid solar panel and wind turbine generator to create electricity for irrigation as well as to store in batteries .Some locations have an abundance of sun, where others have abundance of wind . Having combined system allows us to take the most advantage of prevailing weather condition to maximize energy production.

When one source isn't available the system will still be able to provide energy from alternate energy source, this clean emission free power acts as a reliable backup or supplemental power source. Solar panel requires less maintenance, as well as wind turbines need only little maintenance, and also these two sources are available as an open source, we preferred these two in our hybrid system.[3]

**B. WATER PUMPING:**

The water pump is used to synthetically supply water for a particular task it can be electronically controlled by interfacing it to a microcontroller such as arduino, PIC, AVR etc. Depending upon the control pulse produced in the controller, the ON/OFF control of the motor is

water by any energy is stored in the battery and used for technique artificially is known as pumping. These are domestic applications.

many varieties of water pumping; our project is focused on brushless DC motor to pump water to the field. [2]

**II. MODELLING OF PROPOSED SYSTEM**

**A. MATLAB MODELLING OF WIND & SOLAR:**

The output of solar PV module and wind turbine is nonlinear. In simulation, we evaluate and analyze the power required for operating the water pump by obtaining the voltage from the specified rating of solar panel and wind velocity. The fig 1.2 represents the simulation diagram for proposed modeling in Matlab.

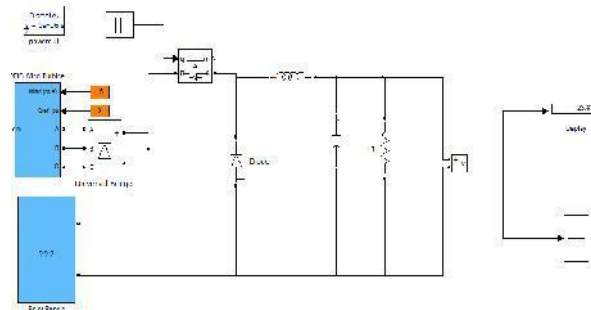

Figure 1.2: Matlab modeling of hybrid system

The output waveform depends upon the input source. The output is the analysis of current and voltage waveforms of two different sources of power production. The output waveform for hybrid system, is shown in the fig 1.3

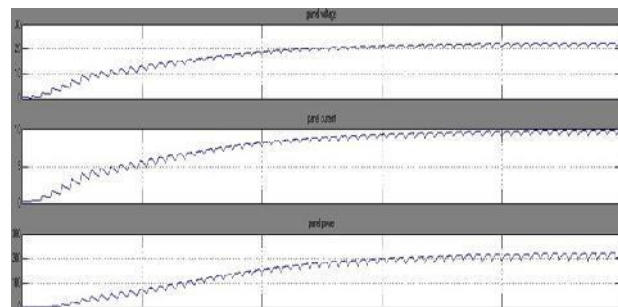

Figure 1.3: Output waveform for hybrid system

### III. CONTROLLER FOR PROPOSED WORK

This paper make use of proteus software for range analysis and arduino controller to generate control signal .There are many controllers which are widely available for different applications



Fig 1.4 : Schematic of Arduino Controller

#### ARDUINO SPECIFICATION

FEATURES	SPECIFICATION
<b>Microcontroller</b>	<b>AT mega</b>
<b>Operating Voltage</b>	<b>328 5V</b>
<b>Input Voltage (recommended) Input Voltage(Limits)</b>	<b>7.12V 6-20V</b>
<b>Digital I/O Pins</b>	<b>14(of which 6 provide PWM output)</b>
<b>Analog Input Pins</b>	<b>6</b>
<b>DC Current for 3.3V</b>	<b>50mA</b>
<b>Pin Dc Current per I/O</b>	<b>40mA</b>
<b>Pin Flash Memory</b>	<b>32KB(AT mega 328)of which 0.5 KB</b>
<b>SRAM</b>	<b>Used by Boot</b>
<b>EEPROM</b>	<b>Loader 2KB(AT</b>
<b>Clock Speed</b>	<b>mega 328) 1KB(AT mega 328) 16MHZ</b>

Table 1.1: Arduino Controller Specifications

Microcontroller is used in digital applications as control unit, the microcontroller family includes: 8051, PIC (programmable interface controller),Arduino and AVR. We chose arduino as a controller, because it is an open source platform for building projects. Arduino consists of both a physical programmable circuit board and software that runs on our computer, used to write and upload computer code to the physical board. Using Arduino: electric equipment’s can be manipulated to respond for change in physical elements like temperature, humidity, heat or even light. The figure 1.4 shows the schematic representation of Arduino controller. An also it’s the table 1.1 gives the detailed specification for Arduino controller. [3]

### IV. SENSING UNIT FOR PROPOSED SYSTEM

#### A. MOISTURE SENSOR

The soil moisture sensor is also known as hygrometer is basically used to sense moisture content in the soil. So, it is preferred to build an automatic watering system or to monitor the soil humidity level of our plants. The sensor is set up by two pieces: the electronic board and the probe with two pads, which detects the water content in the soil. Potentiometer which is inbuilt in sensor is used to adjust sensitivity of digital output, power LED and a digital LED. Voltage varies widely according to the water content in soil. When the soil is:

**Wet:** Decrease in output voltage **Dry:** Increase in output voltage

The digital signal output can be HIGH or LOW, which depends on the moisture content in the soil. If the soil humidity goes beyond a rated predefined threshold value, the output will be LOW, else it will be HIGH. The output is an analog signal so value will be in the range of 0 to 1023. The problem with these sensors is that the probe by itself starts working by measuring the current that passes from one side to another side. Due to this electrolysis takes place so it can destroy the probe (YL-69) quite faster. The fig. 1.5 shows the pictorial representation of moisture sensor.



Figure 1.5: Moisture Sensor

MOISTURE SENSOR SPECIFICATION

Vcc( power supply)	3.3V or 5V
Current	35mA
Signal Output Voltage	0-4.2V
Digital Outputs	0 or 1
Analog	Resistance( $\Omega$ )
Panel Dimension	3.0cm by 1.6cm
Probe Dimension	6.0cm by 3.0cm
GND	Connected to ground

The table 1.2 shows the specification for moisture sensor.

V. WORKING OF PROPOSED SYSTEM

When the solar radiation is incident on solar panel, current will be produced by the principle of 'photovoltaic cell'. Similarly, in wind turbine kinetic energy of wind is converted into mechanical energy later it is converted into electrical energy by the mean of generator. Wind turbine gives out an AC power which is converted into DC by using rectifier. Output from solar and wind are not stable, hence a converter is used. There are various converters are available which are buck, boost, buck and buck-boost converter. Buck converter act as step down transformer, boost converter act as step up transformer, buck-boost converter perform both the operations depending upon the impedance level. Cuck converter is also a type of DC-DC converter. That has an output voltage that is either greater than or less than the

input voltage magnitude. Usually buck converter is implemented in embedded applications as it has low current ripple when compared with other automatic converters in our project, since output from wind turbine is DC power rectifier is not mandatory. Now the pure DC power is stored in battery in order to energize the DC pump supply while the surplus energy in a battery is used to satisfied local loads power requirement. In this paper the following components which are arduino controller, soil moisture sensor, LCD display, MOSFET, optocoupler, DC motor and battery are used. Soil moisture sensor will detect humidity level according to the obtained data arduino will perform switching operation (i.e.) Turn on and off the switch to the pump or load MOSFET is used as a high switching frequency and it is suitable for low power application and it has less voltage and current ratings.



Figure 1.6(a)

Pumping the water to the field for irrigation is required whenever there is insufficient moisture content in the soil. The moisture sensor YL-69, which is connected to the arduino controller detects the moisture content in the soil. If the soil is found to be dry or the moisture content is below its set reference value, the controller generates a pulse signal that will turn ON the switch which is connected in series with the DC pump. This DC pump which pumps the water to the field and makes the land wet that is suitable for irrigation. Similarly when the soil is wet or it contains enough moisture content then the controller will turn ON the switch and starts storing the energy in the battery. The energy stored in the battery which is made use for the domestic applications.



Figure 1.6(b)

**A. FLOW CHART**

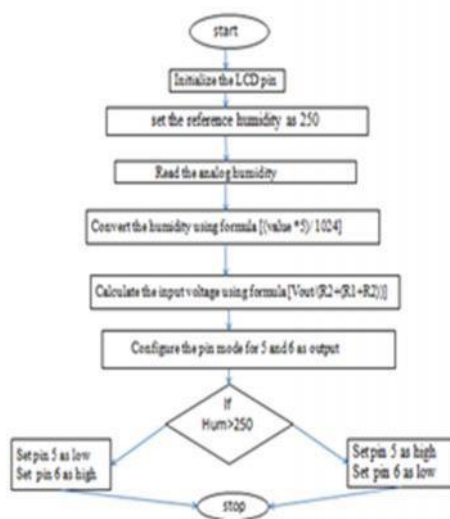

**V. RESULT ANALYSIS**



Figure 1.7(a)

This figure 1.7(a) shows that when the moisture sensor is kept on dry sand and since there is no water content in soil the sensor detected the humidity value and displayed the humidity level as 478 ohm.

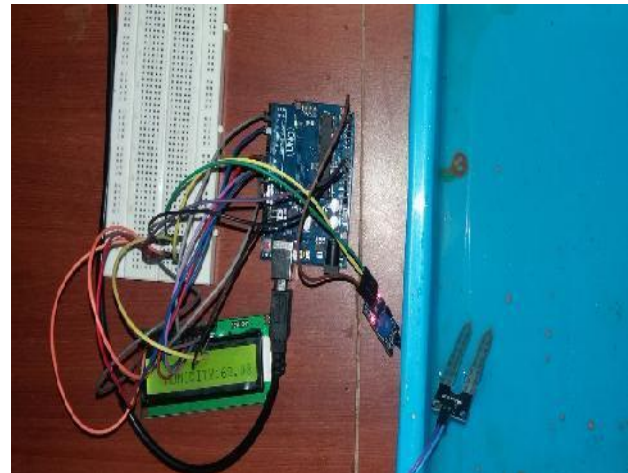

Figure 1.7(b)

This figure 6.1(b) shows humidity level as 169 ohm when the sensor is dipped into pure water



Figure 1.7(c)

Figure 1.7(c) defines that when sensor is inserted into a soil which is partially filled with water, the moisture sensor detected the humidity level as 239 ohm



Figure 1.7(d)

This indicates that when sensor is kept free at room temperature it displayed as 478 ohm.

The moisture content of pure water, mixed water and sand, dry sand, room temperature [no contact with soil or water] were noted practically. The raw data collected from the experiment. Water was added in the soils insteps and sensor values recorded. The table 1.3 shows the analyzed data of moisture sensor at contamination sand and water together.

Table 1.3: Moisture level

S.no	Water /Sand Content	Moisture Level
1.	Pure Water	50-180
2.	Mixed Water And Sand	190-290
3.	Dry Sand	400-440
4.	Room Temperature [No Contact With Soil Or Water]	470-490

## VI. CONCLUSION

Major problems faced by farmers are under irrigation or over irrigation. This project is proposed to minimize the manual intervention by the farmer i.e. on implementing this plan farmer can take more rest as they don't have to go field to turn ON or OFF the pump manually. Arduino based irrigation system is a real time feedback control system which can maintain and control the irrigation activities effectively. This is an idea suggested here to modernize the agriculture at mass scale. This project will be a best way to achieve more production & profit without any compensation with less effort.

## VII. REFERENCE

- [1] Birasalapati Doraswamy, "Automatic Irrigation System using Arduino Controller" SKR College of Engineering and Technology, JNTU Anantapur, AP, India.
- [2] Mrs. S. Senthil Rani, "Hybrid Water Pumping Control System for Irrigation using Arduino" Assistant Professor, Electrical and Electronics Engineering, Velammal College of Engineering and Technology, Madurai, India.
- [3] Brian D.Vick, Byron A. "Neal in Analysis of off-Grid Hybrid Wind Turbine/Solar PV Water Pumping Systems" in science (2012).
- [4] Mrs. S.V. Devika "Arduino Based Automatic Plant Watering System" Assistant Professor, Electrical and Electronics Engineering, HITAM, Hyderabad, India.
- [5] Mr. M. Nagarajapandian "Automatic Irrigation System on Sensing Soil Moisture Content" Assistant Professor, Dept. of EIE, Sri Ramakrishna College of Engineering, Coimbatore, Tamil Nadu.