

# Simulation of a Single-Phase Cycloconverter Based Matrix Converter Topology using MATLAB/Simulink

S.Sudha Rani  
Assistant Professor EEE, MGIT  
Hyderabad, India

Dr. M. Nalini Devi  
Assistant Professor EEE, MGIT  
Hyderabad, India

E.Deepika  
Student EEE, MGIT  
Hyderabad, India

**Abstract**—The field of power electronics mainly deals with the conversion of power from one form to another and the change of voltage level to another by using different power electronic converters. There are many control strategies used in the aid of this conversion. The main types of conversion are cycloconverter, rectifier, inverter and chopper.

A single-phase matrix converter (SPMC) is a power conversion topology that employs a bilateral switch matrix (typically four bidirectional IGBT switches arranged in a 2×2 configuration) to connect an input source directly to an output load without requiring any intermediate DC-link capacitor or energy storage elements. The converter can synthesize a controllable output voltage with variable amplitude and frequency (both higher and lower than the input) while achieving near-unity input power factor and bidirectional power flow capability.

The single-phase cycloconverter is a well-established direct AC-AC frequency changer widely used for low-frequency applications such as speed control of single-phase induction motors and induction heating. Traditionally, it is realized using thyristor-based phase-controlled circuits, which suffer from poor input power factor, high harmonic distortion, and limited output frequency (typically less than or equal to input frequency/3).

The present work implements a single-phase cycloconverter using matrix converter topology in SIMULINK, by leveraging the inherent advantages of matrix converter technology.

**Index Terms**—Cycloconverter, Matrix Converter, AC-AC Conversion, Simulink, Power Electronics

## I. INTRODUCTION

Power electronics fundamentally revolves around efficient, controlled, and reliable energy conversion between different forms to meet the diverse requirements of modern electrical systems. The four primary conversion categories AC-DC (rectification), DC-AC (inversion), DC-DC (chopping), and direct AC-AC (frequency/amplitude alteration) address nearly all industrial and domestic needs.

Among these, direct AC-AC conversion without an intermediate DC link has always been desirable because it potentially offers higher efficiency, reduced size, lower cost, and longer lifetime by eliminating bulky electrolytic capacitors. While controlled rectifiers and inverters connected through a DC link

dominate most applications, direct AC-AC topologies become particularly attractive in scenarios demanding compact design, high reliability, four-quadrant operation, and sinusoidal input current with unity power factor.

Traditional single-phase AC-AC conversion for variable-frequency applications has been largely synonymous with the thyristor-based cycloconverter, a naturally commutated direct frequency changer capable of producing output frequencies lower than the input (typically limited to  $f_o/3$ ).

Despite its simplicity and robustness, the conventional cycloconverter suffers from well-documented drawbacks:

- poor input power factor that deteriorates severely at low output frequencies
- high harmonic distortion in both input current and output voltage
- subharmonic generation
- limited maximum output frequency ( $f_o \leq f_s/3$ )

These shortcomings make it increasingly incompatible with modern grid codes, electromagnetic compatibility standards, and energy-efficiency regulations, thereby motivating the search for alternative topologies that retain the advantages of direct conversion while overcoming the limitations of phase-controlled thyristor circuits. This is the reason for the tremendous interest in matrix converter topology as the ideal features can be fulfilled.

### A. Problem Statement and Project Objectives

**Problem Statement:** Conventional single-phase thyristor cycloconverters suffer from: output frequency limited to one-third of input frequency, High low-order harmonics, poor input power factor that deteriorates severely at low output frequencies. These limitations restrict their use in modern high-performance drives. Single Phase Matrix Converter is proposed as a potential solution to meet all the requirements of the ideal frequency changer.

**Primary Objectives:** The objective of this work is to design and validate in MATLAB/Simulink a high-performance single-phase cycloconverter using 2×2 matrix converter topology

that overcomes the limitations of conventional thyristor-based designs by:

- 1) Implementing safe four-step commutation with IGBT-based bidirectional switches
- 2) Achieving sinusoidal output voltage at any frequency

The AC-AC converter is used to convert an alternating voltage at supply frequency is converted directly to an alternating voltage at load frequency. The proposed converter topology is more efficient when compared to the conventional converters to overcome the drawbacks and achieve the true single stage cycloconversion with superior waveform quality.

## II. LITERATURE REVIEW

The modern industrial landscape and motion control systems heavily rely on power electronic converters to achieve efficient and flexible energy conversion. Traditional AC-AC converters often utilize an intermediate DC link, which necessitates bulky and short-life reactive energy storage components (capacitors and inductors). This drawback led researchers to investigate direct AC-AC power conversion topologies, most notably the matrix converter (MC).

- Maxym Vorobyov, "Overview of Single Phase Matrix Converter Applications"
- Zuckerberger, A., Weinstock, D., Alexandrovitz A., "Single-phase Matrix Converter," IEE Proc. Electric Power App, Vol.144(4), Jul 1997 pp 235-240.
- Modelling Simulation of Single-phase Matrix Converter as a Frequency Changer with Sinusoidal Pulse Width Modulation Using MATLAB/Simulink ,Conference: Power and Energy Conference, 2006. PECon '06. IEEE International.
- B. R. Pelly, Thyristor Phase-Controlled Converters and Cycloconverters, Wiley, New York, 1971
- Zahiruddin Idris, siti Zaliha mahammud noor, Mustafar kamal Hamza "Safe Commutation Strategy in Single Phase Matrix Converter" IEEE PEDS 2005 Conference.

The single-phase matrix converter (SPMC)-based cycloconverters, pioneered by Zuckerberger (1997) and advanced by Idris and Hamzah (2005–2006), successfully overcome the classic thyristor cycloconverter limitations documented by Pelly (1971)—poor power factor, high THD, subharmonics, and four  $\pi/3$ —while eliminating DC-link capacitors and achieving unity power factor and low distortion through sinusoidal PWM and safe four-step commutation.

Despite mature theory and numerous Simulink validations, comprehensive, fully integrated, and openly accessible models remain scarce. This work fills that gap by delivering a complete, high-performance, validated Simulink implementation of the SPMC cycloconverter for both resistive and inductive loads across a wide frequency range.

## III. PROPOSED METHODOLOGY

### A. Matrix Converter Topology

The Matrix Converter is a single-stage converter which has an array of  $m \times n$  bidirectional power switches to connect, directly, an  $m$ -phase voltage source to an  $n$ -phase load. It is also defined as is a forced commutated converter which uses an array of controlled bidirectional switches as the main power elements to create a variable output voltage system with unrestricted frequency. As shown in the figure 1, the Single-Phase Matrix Converter (SPMC) consists of a matrix of input and output lines with four bidirectional switches connecting the single-phase input to the single-phase output at the intersection. Normally, the matrix converter is fed by a voltage source and, for this reason the input terminals should not be short circuited. On the other hand, the load has typically an inductive nature and, for this reason, an output phase must never be opened.

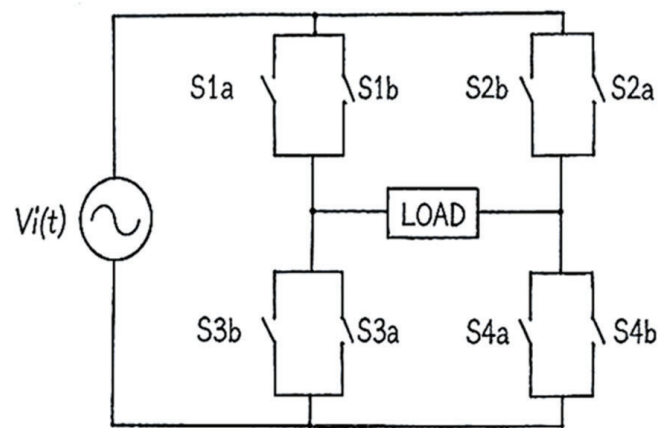

Fig. 1. Basic Circuit of Single Phase Matrix Converter

The Single phase matrix converter circuit as shown in Fig 1 uses four bi-directional switches for the implementation of single phase Cycloconverter. It requires the use of bi-directional switches capable of blocking voltage and conducting current in both directions. Unfortunately there is no discrete semiconductor device. Currently that could be fulfilling the needs and hence the use of common-emitter anti-parallel IGBT, diode pair as shown in Fig 2 . Diodes are in place to provide reverse blocking capability to the switching module. The IGBT were used due to its high switching capabilities and high current carrying capabilities desirable amongst researchers for high power applications.

### B. Control Strategy

To enable a Single Phase Matrix Converter (SPMC) to function as a cycloconverter, driver circuits are designed to generate specific control pulses for the power switches (IGBTs). In this implementation, pulse generation is achieved using MATLAB/Simulink (MLS) via pulse generator blocks and logic gates. The SPMC architecture consists of four bidirectional switches ( $S_1$  to  $S_4$ ). Each switch is labeled with

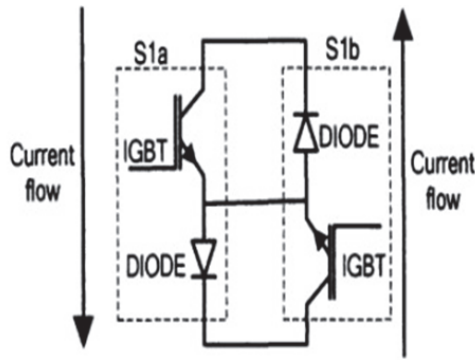

Fig. 2. Schematic view of Bi-directional switch (common - emitter)

”a” or ”b” markers to denote the current flow direction: ”a”: Forward direction.”b”: opposite direction.

1. Step-Down Operation (25Hz and 12.5Hz)

With an input frequency of 50Hz, the desired output frequencies are synthesized at 25Hz and 12.5Hz by sequencing the gate triggering pulses.

As shown in figure 3 the biasing and triggering logic for the load cycles are as follows: Biasing Conditions Positive Input Half-Cycle: Switches  $S_{1a}$ ,  $S_{2b}$ ,  $S_{3b}$ , and  $S_{4a}$  are forward biased. Negative Input Half-Cycle: Switches  $S_{1b}$ ,  $S_{2a}$ ,  $S_{3a}$ , and  $S_{4b}$  are forward biased. Triggering Logic for Load Synthesis To obtain a positive load cycle: During the positive input half-cycle: Trigger  $S_{1a}$  and  $S_{4a}$ . During the negative input half-cycle: Trigger  $S_{3a}$  and  $S_{2a}$ . To obtain a negative load cycle: During the positive input half-cycle: Trigger  $S_{2b}$  and  $S_{3b}$ . During the negative input half-cycle: Trigger  $S_{4b}$  and  $S_{1b}$ . in Table 1 The specific sequence of these states over various time intervals determines the final output frequency.

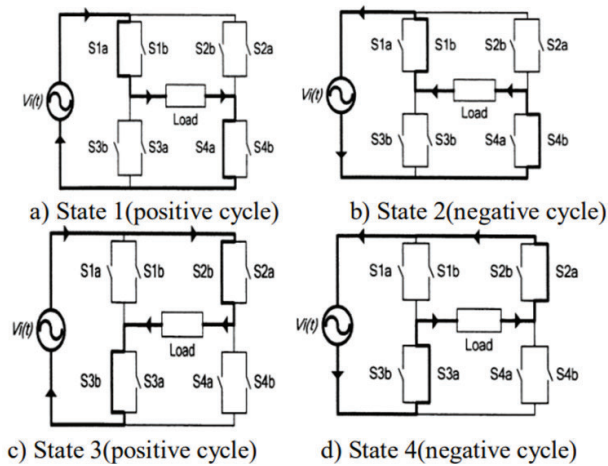

Fig. 3. Different states for the operation of the Cycloconverter

2. Step-Up Operation (100Hz and 150Hz)

For step-up operation, the output frequency is synthesized as multiples of the 50Hz input (e.g., 100Hz and 150Hz). This

TABLE I  
 SWITCHING SEQUENCE OF STEPDOWN CYCLOCONVERTER

Input frequency	Target output frequency	Time interval	State	Switch “modulated”
50 Hz	25Hz	1	1	S1a and S4a
		2	4	S2a and S3a
		3	3	S2b and S3b
		4	2	S1b and S4b
	12½ Hz	1	1	S1a and S4a
		2	4	S2a and S3a
		3	1	S1a and S4a
		4	4	S2a and S3a
		5	3	S2b and S3b
		6	2	S1b and S4b
		7	3	S2b and S3b
		8	2	S1b and S4b

requires higher-frequency switching within each input half-cycle. Commutation and Safety A critical aspect of the SPMC is safe commutation to handle inductive loads.

Control Mechanism: During a positive supply voltage (e.g., at 50Hz output synthesis),  $S_{4a}$  acts as the primary controlling switch. Continuous Conduction:  $S_{1a}$  and  $S_{2a}$  are maintained in a ”continuously ON” state during this cycle.  $S_{1a}$  completes the loop for output synthesis.  $S_{2a}$  acts in conjunction with  $S_{1a}$  to provide a freewheeling path whenever  $S_{4a}$  is turned OFF. Dead-time Period: The commutation period is designed to extend over the dead-time. This allows stored energy to dissipate, effectively eliminating current reversals caused by inductive loads.

TABLE II  
 SWITCHING SEQUENCE OF STEPUP CYCLOCONVERTER

Input Frequency	Output Frequency	Time Interval	State	Switch Modulated	Commutation Switch “ON”
50Hz	50Hz	1	1	S1a & S4a	S2a
		2	2	S1b & S4b	S2b
	100Hz	1	1	S1a & S4a	S2a
		2	3	S2b & S3b	S1b
		3	4	S2a & S3a	S1a
		4	2	S1b & S4b	S2b
	150Hz	1	1	S1a & S4a	S2a
		2	3	S2b & S3b	S1b
		3	1	S1a & S4a	S2a
		4	2	S1b & S4b	S2b
		5	4	S2a & S3a	S1a
		6	2	S1b & S4b	S2b

The proposed single-phase cycloconverter based on Single-Phase Matrix Converter (SPMC) topology eliminates the drawbacks of conventional thyristor-based designs by offering direct AC-AC conversion without a DC link. The switching

strategy of stepdown cycloconverter and stepup cycloconverter had discussed. This control strategy overcomes the inherent limitations of conventional thyristor cycloconverters and fully exploits the advantages of matrix converter topology, delivering superior waveform quality, extended frequency range, and safe operation.

#### IV. MATHEMATICAL MODELLING

A cycloconverter is a direct frequency converter that converts a fixed AC voltage and fixed frequency (e.g., 50/60 Hz) directly into a variable AC voltage at a lower output frequency without an intermediate DC link. It is essentially a collection of controlled thyristor (SCR) rectifiers connected in anti-parallel (back-to-back) to produce positive and negative half-cycles of the output waveform.

Types of Cycloconverters

- Step-down cycloconverter: Output frequency  $fo \leq fs$  (input supply frequency). Uses natural commutation (line commutation) of thyristors, making it simpler and more common for applications like low-speed drives.
- Step-up cycloconverter :  $fo > fs$ . Requires forced commutation to turn off thyristors prematurely, which adds complexity and is less practical due to poor waveform quality and higher harmonics.

#### A. For a resistive load

$$V_{o(avg)} = \frac{2V_m}{\pi} \cos \alpha \quad (1)$$

$$I_{o(avg)} = \frac{V_o}{R} \quad (2)$$

$$V_{orms} = V_{in} \sqrt{1 - \frac{\alpha}{\pi}} \quad (3)$$

$$I_{orms} = \frac{V_{orms}}{R} = 3.25A \quad (4)$$

Example Calculation

Given:

- Input Voltage = 230V
- Frequency = 50Hz
- Resistance = 50Ω

$$V_{o(avg)} = \frac{690}{\pi} = 146.422V \quad (5)$$

$$I_{o(avg)} = \frac{146.422}{50} = 2.92A \quad (6)$$

$$V_{orms} = 162.6 \sqrt{1 - \frac{1}{\pi}} = 162.634V \quad (7)$$

$$I_{orms} = \frac{162.6}{50} = 3.25A \quad (8)$$

#### B. For an induction motor as load

Given:

- Rated power = 0.25 HP
- Rated Voltage = 230 V
- Input Frequency = 50 Hz
- firing angle:  $\alpha = 15^\circ = \frac{\pi}{12}$
- $V_{in,rms} = 230V$

$$V_{orms} = V_{in} \sqrt{1 - \frac{\alpha}{\pi}} \quad (9)$$

$$V_{orms} = 230 \sqrt{1 - \frac{1}{12}} = 220.1V \quad (10)$$

The calculations are done by considering the formulas of conventional cycloconverter. This analytical foundation supports accurate simulation in Simulink, provides insight into harmonic performance and switching constraints.

#### V. SIMULATION MODEL

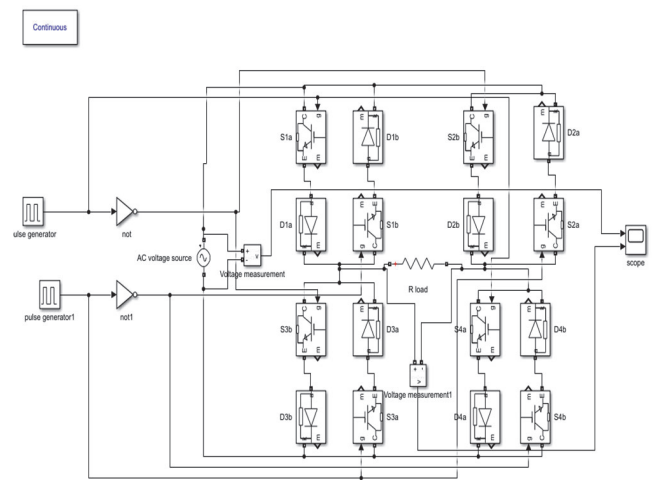

Fig. 4. Simulation circuit of matrix converter as cycloconverter with R load

The system is tested under:

- Resistive Load
- Induction Motor Load

#### A. Simulation circuit of Matrix converter with R load

The switching sequences for the Single Phase Matrix Converter (SPMC) are synthesized using a pulse-generator-based control scheme. This system utilizes four bidirectional switches ( $S_1, S_2, S_3, S_4$ ), each realized using a common-emitter configuration of two IGBTs and two anti-parallel diodes. This arrangement is essential for blocking voltage and conducting current in both directions within the matrix-like structure.

- Pulse Generation and Timing The control pulses are generated through two primary pulse generator blocks within the simulation environment. The timing parameters are defined as follows:

- Time Period: Calculated based on the desired output frequency (e.g., for 100Hz and 150Hz operations as per Table 2).
- Duty Cycle: The pulse width is fixed at 50
- Logic Synthesis: NOT gate blocks are utilized to complement the primary pulse generator outputs, ensuring synchronized gate signals for the bidirectional switch pairs.
- Switching Topology : The matrix configuration facilitates direct AC-AC conversion by routing the input cycles to the load as follows: $S_1$  and  $S_3$ : Responsible for connecting the positive input cycle to the load terminals.  $S_2$  and  $S_4$ : Configured to manage the negative input cycle transitions.
- Operational Principle and Load The system is designed to provide a controlled AC output from a fixed AC input voltage. By precisely modulating the "ON" and "OFF" intervals of the gate pulses, the output frequency and voltage magnitude are adjusted to meet the requirements of the connected load. To simulate industrial performance, the model is tested using:
  - Resistive (R) Load
  - Induction Motor Load: To evaluate the converter's effectiveness in speed control and torque performance under real-world conditions.

**B. Simulation circuit of matrix converter with Induction motor load**

In the figure 5 and figure 6 circuit configuration remains unchanged however, the load is replaced with an induction motor to examine the effects of step-up and step-down frequency variations on its performance respectively. This modification provides a practical perspective on the application of the system. The specifications of the induction motor used are: rated power of 0.25 HP, rated voltage of 230 V, and rated current in the range of 1.2–1.6 A.

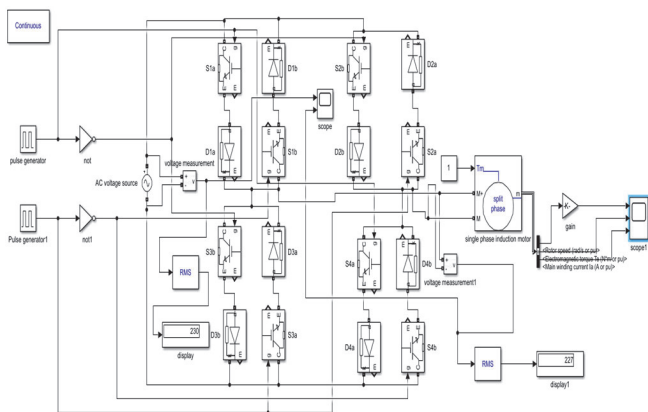

Fig. 5. Simulation circuit of matrix converter as cycloconverter with Single Phase Induction Motor load(25 Hertz stepdown cycloconverter )

The output voltage waveforms are observed to analyze the system performance under varying operating conditions. In addition, the input RMS voltage and output RMS voltage

are measured using display blocks, enabling a quantitative comparison of voltage levels across the system.

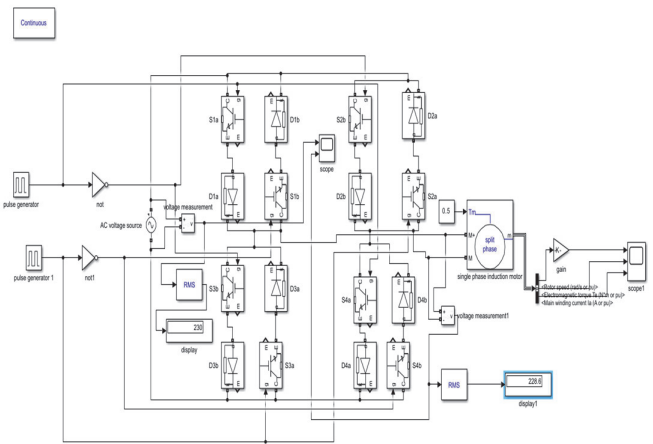

Fig. 6. Simulation circuit of matrix converter as cycloconverter with Single Phase Induction Motor load(100 Hertz stepup cycloconverter )

The proposed matrix converter is implemented as a cycloconverter using MATLAB/Simulink. The model provides detailed information on the Simulink block diagram and the key components used in its design. In the present implementation, pulse generator-based control with NOT gate blocks is employed to generate gating pulses.

**VI. RESULTS AND DISCUSSION**

The simulation results are summarized and provides a detailed performance analysis of the single-phase cycloconverter implemented using a matrix converter topology in Simulink .The converter is tested with a range of load variations and different frequencies. The system performance is assessed by observing key output parameters such as output voltage, current, speed, and torque of induction motor. These parameters are monitored using scope and display blocks.

**A. R Load Output**

For the given circuit, the input voltage has a frequency of 50 Hz and a peak voltage of 230 V.

In Figure 7, the first waveform represents the input voltage (50 Hz). The second waveform represents the output voltage. In this case, one positive half-cycle of the output is obtained for each full cycle of the input. This means that for every two input cycles, we get one complete output cycle. Therefore, the output frequency is reduced to 25 Hz, which is half of the input frequency. As a result, the time period increases, since frequency and time period are inversely proportional.

In Figure 8, the first waveform again represents the input voltage (50 Hz, 230 V peak voltage ). The second waveform is the output voltage. Here, one full cycle of the output is obtained from each half-cycle of the input. This means that for every one input cycle, we get two output cycles. Therefore, the output frequency is increased to 100 Hz, which is twice

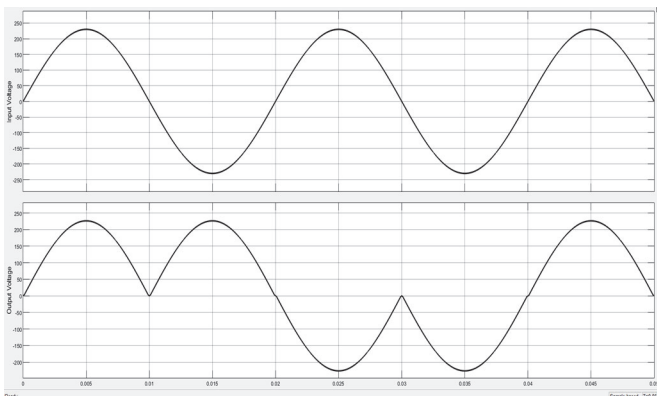

Fig. 7. Input and Output voltage waveforms of stepdown cycloconverter(R load)

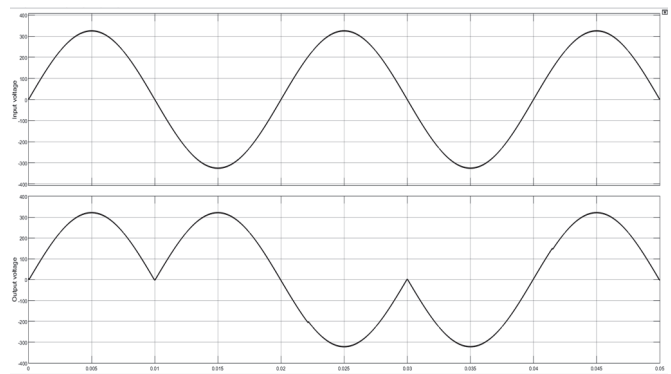

Fig. 9. Output voltage waveform of stepdown cycloconverter(Induction motor load)

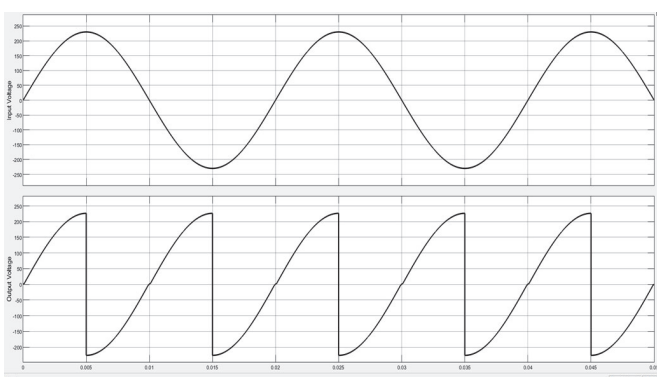

Fig. 8. Input and Output voltage waveforms of stepup cycloconverter(R load)

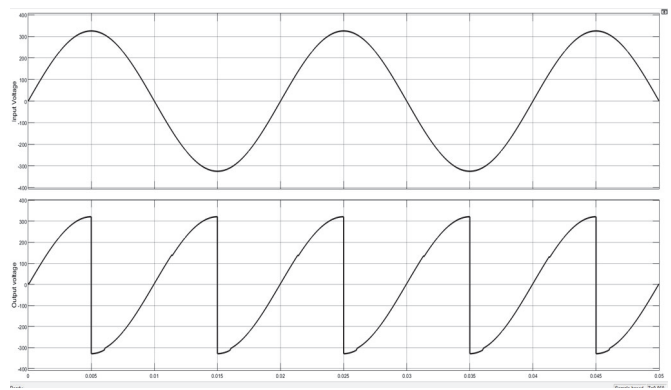

Fig. 10. Output voltage waveform of stepup cycloconverter(Induction motor load)

the input frequency. Consequently, the time period decreases, again due to the inverse relationship between frequency and time period.

### B. Induction motor Load Output

In this setup, the load is a single phase induction motor. The input RMS voltage supplied to the circuit is 230 V. In the case of step-down frequency operation, the output RMS voltage from the cycloconverter is 227.1 V, which is applied to the motor as its input voltage. In the case of step-up frequency operation, the output RMS voltage from the cycloconverter is 228.6 V maintained close to the input value and is applied to the motor.

The figure 9 shows both the input and output voltage waveforms of the step-down cycloconverter. The output waveform has a lower frequency than the input, corresponding to the step-down operation, while maintaining nearly the same RMS voltage level. Similarly, The figure 10 shows both the input and output voltage waveforms of the step-up cycloconverter. The output waveform has a higher frequency than the input, corresponding to the step-up operation, while maintaining nearly the same RMS voltage level.

### C. Induction Motor Performance

From the induction motor by using bus selector we have selected Rotor speed, Electromagnetic Torque, Main winding

Current given to the scope block.

- In practical operation, an induction motor does not run exactly at synchronous speed but slightly below it due to a phenomenon called slip. Rotor Speed ,  $N = N_s(1-s)$  where  $s$  is the slip  $N_s$  is the synchronous speed
- The supply frequency directly affects the rotor speed of an induction motor because the rotor speed follows the rotating magnetic field produced by the stator. In the figure 11 when the frequency decreases, the rotating magnetic field slows down, and the rotor speed decreases.
- Similarly, In the figure 12 When the frequency increases, the rotating magnetic field in the stator rotates faster, causing the rotor to also speed up However, the rotor never reaches the exact speed of the rotating field; it always runs slightly slower due to slip, which is necessary for torque production in the motor.
- When the frequency decreases, the synchronous speed reduces and slip increases, which can increase rotor current and torque demand. However, the main winding reactance also decreases, leading to a higher main winding current for the same applied voltage. It is shown in the figure 11.
- When the supply frequency increases, the synchronous speed increases, which reduces the slip for a given

rotor speed. This reduces the induced rotor current and therefore affects the electromagnetic torque.

- At the same time, the stator (main winding) inductive reactance  $X = 2\pi fL$  increases with frequency, which increases the overall impedance of the main winding. As a result, the main winding current generally decreases at higher frequencies if the applied voltage is kept constant. These changes are shown in the figure 12

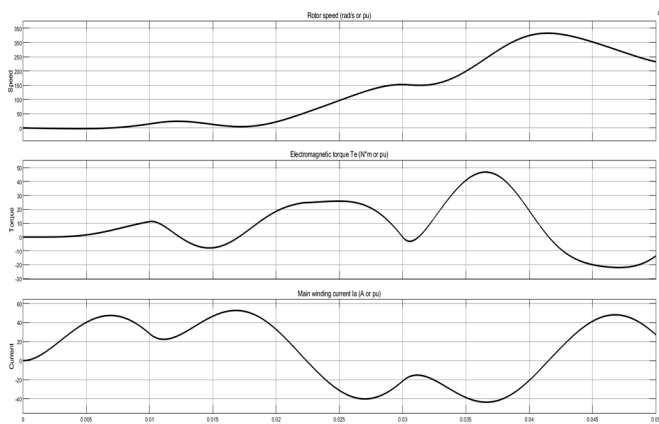

Fig. 11. output waveforms of single phase induction motor (25 hertz stepdown cycloconverter)

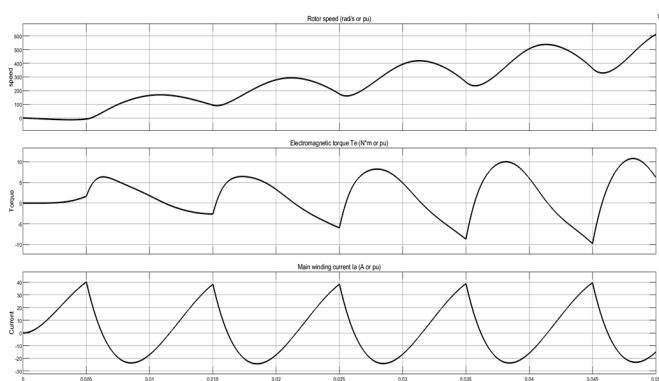

Fig. 12. output waveforms of single phase induction motor (100 hertz stepup cycloconverter)

From the analysis of different loads such as R load, and single-phase induction motor load, the performance of the cycloconverter has been successfully evaluated. For purely resistive (R) load, the output voltage closely follows the expected stepped frequency operation with minimal distortion.

For the single-phase induction motor load, the cycloconverter effectively controls the supply frequency, which directly influences the rotor speed of the motor. It is observed that a reduction in frequency leads to a decrease in motor speed, while an increase in frequency results in higher speed. However, due to the non-sinusoidal nature of the output waveform, harmonic distortion is present,

which affects torque smoothness, increases losses, and may slightly impact efficiency.

#### D. Comparative Analysis

The performance improvements against proposed method are quantified in Table III.

TABLE III  
 COMPREHENSIVE PERFORMANCE COMPARISON OF CONVENTIONAL CYCLOCONVERTER AND PROPOSED SPMC

Parameter	Conventional Thyristor	Proposed SPMC
DC Link	Not required	Not required
Output Frequency Range	$\leq f_s/3$	Up to $f_s/2$ (theoretically)
I/O Waveform Quality	High low-order harmonics	Near sinusoidal with PWM
Input Power Factor	Poor and load dependent	Near unity and controllable
Number of Power Switches	4 Thyristors	4 Bidirectional switches
Commutation Strategy	Line (natural)	Forced (four-step or semi-soft)
Reactive Components	Large output filter	Minimal filtering needed

The SPMC-based cycloconverter extends the frequency range beyond the traditional  $f_s/3$  limit while achieving near-unity input power factor and near-sinusoidal waveforms. The design eliminates the bulky filtering and low-order harmonics inherent in thyristor-based systems. This transition results in a more compact, efficient, and precisely controllable AC-AC power conversion topology.

### VII. CONCLUSION AND FUTURE SCOPE

#### A. Conclusion

The cycloconverter-based matrix converter has been successfully implemented, and analyzed for different types of loads such as R, RLC, and single-phase induction motor. The results demonstrate that the cycloconverter is capable of converting a fixed input frequency into variable output frequencies in both step-down and step-up modes. For resistive and RLC loads, the output waveforms follow the expected frequency conversion, though some distortion is observed due to switching action and the presence of reactive components.

For the single-phase induction motor load, it is observed that the variation in output frequency directly controls the rotor speed of the motor. A decrease in frequency results in reduction in motor speed, while an increase in frequency leads to higher speed operation. However, the non-sinusoidal nature of the output waveform introduces harmonic distortion, which affects torque smoothness, increases losses, and slightly reduces overall efficiency. Despite these limitations, the system effectively demonstrates frequency-based speed control of induction motors.

Hence the developed single phase cycloconverter based matrix converter topology offers significant advantages, as it acts as a universal power converter capable of rectifier, inverter, chopper, and cycloconverter conversions. It finds wide applications in motor drives, renewable energy

systems such as wind and solar power, electric vehicles, and aerospace systems. The simulation results confirm that the matrix-based cycloconverter provides better performance in terms of compact design and efficient power conversion.

### B. Future Scope

In future, the performance of the cycloconverter system can be further improved by implementing advanced control techniques such as PWM-based switching methods, space vector modulation to reduce harmonic distortion.

### REFERENCES

- [1] Maxym Vorobyov, "Overview of Single Phase Matrix Converter Applications"
- [2] Zuckerberger, A., Weinstock, D., Alexandrovitz A., "Single-phase Matrix Converter," IEE Proc. Electric Power App, Vol.144(4), Jul 1997 pp 235-240.
- [3] Modelling Simulation of Single-phase Matrix Converter as a Frequency Changer with Sinusoidal Pulse Width Modulation Using MATLAB/Simulink, Conference: Power and Energy Conference, 2006. PECon '06. IEEE International.
- [4] B. R. Pelly, Thyristor Phase-Controlled Converters and Cycloconverters, Wiley, New York, 1971.
- [5] Zahirruddin Idris, Siti Zaliha Mahmud Noor, Mustafar Kamal Hamza "Safe Commutation Strategy in Single Phase Matrix Converter" IEEE PEDS 2005 Conference.
- [6] Hosseini, S.H.; Babaei, E. "A new generalized direct matrix converter," Industrial Electronics, 2001. Proc. ISIE 2001. Vol(2), 2001 pp 1071-1076.
- [7] Wheeler, P.W., Rodriguez, J., Clare, J.C., Empringham, L., Weinstein, A., "Matrix converters: a technology review," IEEE Transactions on Industrial Electronics, Vol. 49(2), April 2002, pp. 276-288.
- [8] P. Deivasundari and V. Jamuna, "Single phase matrix converter as an all silicon solution," Journal of Electrical Engineering, Vol. 11, no. 3, 2011.
- [9] Maamoun, A., "Development of cycloconverters," Canadian Conference (1), Jan-Feb 2004, pp. 59-65. on Electrical and Computer Engineering, 2003. IEEE CCECE 2003.
- [10] Wheeler, P.W., Rodriguez, J., Clare, J.C., Empringham, L., Weinstein, A., "Matrix converters: a technology review," IEEE Transactions