

RFID and GPS based Effective transport system

Prof. Suchitra M

Department of ECE, VVCE, Mysore,
Karnataka

Prof. Bhargavi K

Department of ECE, VVCE, Mysore,
Karnataka

Apoorva K.B

Department of ECE, VVCE, Mysore,
Karnataka

Harshitha M

Department of ECE, VVCE, Mysore,
Karnataka

Manasa R

Department of ECE, VVCE, Mysore,
Karnataka

Tanveer Khan

Department of ECE, VVCE, Mysore,
Karnataka

Abstract- In India, the most widely used public transport system is the bus facility. In the daily operation of bus transport system the movement of vehicles is affected by different uncertain conditions as the day progress, such as traffic congestion, unexpected delays, irregular vehicle-dispatching times, other incidents. Automatic ticketing system will automatically identify the passenger and deduct the passenger's fare according to the distance travelled. The Radio Frequency Identification (RFID) card and GPS are used to make the identification of passenger and transaction very precise. RFID cards distributed to the public have unique ID and are stored in a database along with personal data and create accounts for each person. By accessing this database, it is thus possible to identify the traveller, check his account and deduct the fare from his/her account. Fare calculation is done with the help of GPS module. So a change in fare does not create any confusion as fare calculation is done by evaluating position by GPS module. Over speed is the major concern in the present era as it's the major cause of road accidents. GPS is used to detect the speed of the bus and warn the driver about his misconduct and the message is also sent to the control room to take further actions

Keywords—RFID tag, GPS, Automated ticketing, RTOS

I. INTRODUCTION

Among all public transportation services, bus service is the major transportation used by public. Especially in a busy town or city, bus is the most easy, convenient and cheaper transportation. Various reasons that people take bus instead of driving own vehicle such as traffic jam, heavy parking fee and lack of parking slot in destination.

However, bus transportation service has very poor transportation information system nowadays. Bus user do not know the exactly arrival time for a bus, but only know the scheduled arrival time. Compare to train or flight transportation system, bus transportation service does not have a proper system to track all buses position and the actual arrival time in every bus stops. These problems occur because current bus service system did not apply real time tracking

technology to track on each buses on the road and also lack of a platform to update latest bus traffic information to bus users.

In order to solve these problems and enhance current bus service system, real time bus tracking system has to develop and implement. With real time bus tracking system, bus position data is connected real time and transmitted to a central server for processing and extracting transit information. The main technology used to develop this system is Global Positioning System (GPS). GPS technology able to receive the position of an object from space-based satellite navigation system through a GPS receiver. The developed bus tracking system will be able to provide bus users a real-time platform to check on updated bus traffic information, for examples bus arrival or departure time. Besides, this system also able to reduce workload for bus management team and provide an immediate platform to update latest and accurate bus traffic information to bus users. Road accidents have rose to a large extent in recent days, so over speeding is another problem solved in this project.

There were many works previously carried out related to the ticketing system RFID, Prasun chowdhury et.al [1] portraits about automatic detection about passengers fare according to the distance travelled but also notify the passengers about the next en route. An interface is built between RFID setup and drivers mobile phone using a developed RFID android app "SwipeNgo". Roman khoeblal et.al [2] suggests a RFID distance can combine with people counting techniques as a tool to locate and monitor passengers. RFID based ticketing system uses a smart card called OV-chip card. It decreases fare dogging. Previously carried out work on over speed control, Mohd. Shahid et.al [3] suggests a digital speedometer which has passwords and speed limit control facility, which can reduce over speed accidents. It presents the digital speedometer using the IR sensors. The system permits the control of relay which controls the acceleration of the vehicle via the electronic control unit installed in the vehicle. many work carried out on tracing of the bus include Safa Abd Elmonem et.al [4] is based on arduino, GSM/GPS and map suit Asp.mvc provides the actual arrival time in addition to graphically showing the bus location on google map. Nalawade S R et.al [5] suggest a bus monitoring

system using raspberry pi. It is used to embed the bus, which is alinux code that is programmable and different modules like sensors and GSM/GPRS is inserted to increase its functionality. The gsm technology is used to get geo location information and send alert message while GPRS interacts with web server.

II. SYSTEM DESCRIPTION

A. System architecture

This project combines RFID and GPS technology to design an automatic bus ticketing, tracking and over speed system as shown in Fig.1. The controlling device of the whole system is the Cortex m4 ARM processor. GPS receiver, keypad, smart card reader, LCD display are interfaced to the controller. The location coordinates of the passengers arrival location is stored in the arm processor against his smart card number. The Arm processor calculates the distance travelled and fair of the passengers at a destination location when the smart card is swipe against the RFID reader. The buzzers used to indicate low balance of the card or fair dogging. The buzzer used near the driver is used to indicate the over speed violation. The ticketing and the tracking module are interfaced to get the GPS location coordinates for the tracking purpose and to complete the smart bus.

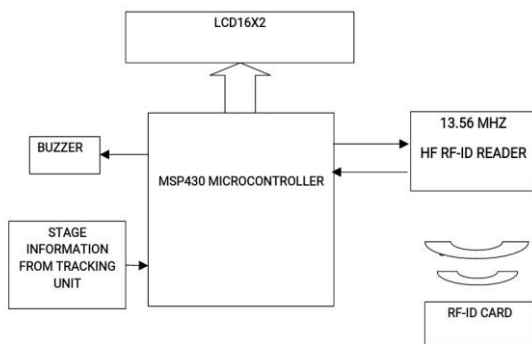

Fig.1. Block diagram of system architecture

B. System format

(i) LCD interfacing with Microcontrollers-4bit mode: In 4-bit mode the data is sent in nibbles, first we send the higher nibble and then the lower nibble. The interfacing of the LCD is shown in Fig.2. To enable the 4-bit mode of LCD, we need to follow special sequence of initialization that tells the LCD controller that user has selected 4-bit mode of operation.

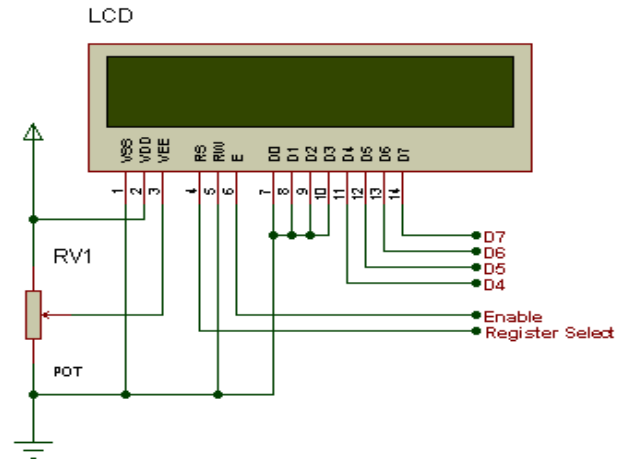

Fig.2. LCD connections in 4-bit Mode

Above is the connection diagram of LCD in 4-bit mode, where we only need 6 pins to interface an LCD. D4-D7 are the data pins connection and Enable and Register select are for LCD control pins. We are not using Read/Write (RW) Pin of the LCD, as we are only writing on the LCD so we have made it grounded permanently. If you want to use it. Then you may connect it on your controller but that will only increase another pin and does not make any big difference. Potentiometer RV1 is used to control the LCD contrast. The unwanted data pins of LCD i.e. D0-D3 are connected to ground.

(ii) ARM cortex M4 Processor

The ARM Cortex-M4 is a general purpose, 32-bit microprocessor, which offers high performance and very low power consumption. The ARM Cortex-M4 offers many new features, including a Thumb-2 instruction set, low interrupt latency, hardware divide, interruptible multiple load and store instructions, automatic state save and restore for interrupts, tightly integrated interrupt controller with wake-up interrupt controller, and multiple core buses capable of simultaneous accesses. Pipeline techniques are employed so that all parts of the processing and memory systems can operate continuously. Typically, while one instruction is being executed, its successor is being decoded, and a third instruction is being fetched from memory.

(iii) General purpose DMA controller

The GPDMA enables peripheral-to-memory, memory-to-peripheral, peripheral-to-peripheral, and memory-to-memory transactions. The source and destination areas can each be either a memory region or a peripheral, and can be accessed through the AHB master. The GPDMA controller allows data transfers between the USB and Ethernet controllers and the various on-chip SRAM areas. The supported APB peripherals are SSP0/1, all UARTs, the I2S-bus interface, the ADC, and the DAC

(iv) RTOS

Real Time Engineers Ltd. Developed RTOS as free and open source specifically for small footprint embedded system to fit for corresponding implements. Only function list that are minimal like management of memory, task handling, synchronization etc without providing for communication in

network for file system to access hardware driver externally. It has the following features like task on Pre-emptive and can support multiple architecture of controller by its specific manufacturer that is written in C and different compiler of C. There is no limitation for number of tasks that are allowed to execute in a desired time with their priorities affords hardware for long operational time by implementing semaphores, binary and queues.

(v) RFID TAG

The amount of data storage on a tag can vary, ranging from 16 bits on the low end to as much as several thousand bits on the high end. of course, the greater the storage capacity, the higher the price per tag.

The tag and antenna structure can come in a variety of physical form factors and can either be self-contained or embedded as part of a traditional label structure (i.e., the tag is inside what looks like a regular bar code label—this is termed a 'smart label') companies must choose the appropriate formfactors for the tag very carefully and should expect to use multiple form factors to suit the tagging needs of different physical products and units of measure. for example, a pallet may have an rfid tag fitted only to an area of protected placement on the pallet itself. on the other hand, cartons on the pallet have rfid tags inside bar code labels that also provide operators human-readable information and a back-up should the tag fail or pass through non rfid-capable supply chain links.

C. Description of hardware setup

The tracking, over speed and ticketing module is shown in Fig3. The controlling device of the whole system is a Cortex M3 Arm Processor. GPS receiver, keypad, smart card reader, LCD display are interfaced to the controller.

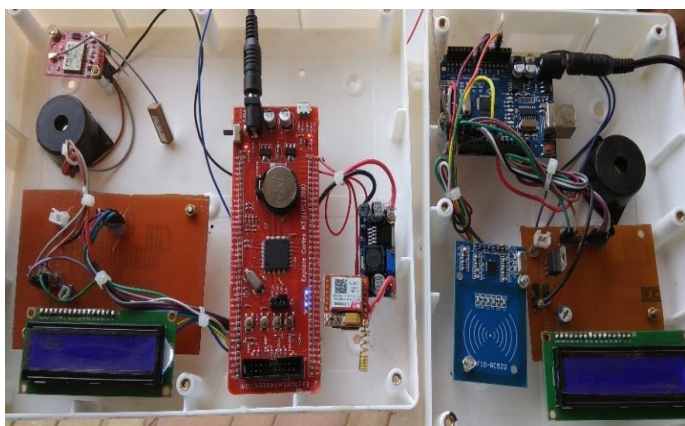

Fig3: Tracking, Overspeed and Ticketing module

(i) When a person boards a bus, he needs to swipe the RFID card to the RFID card reader present at the entrance.

(ii) The location coordinates at that instant given by GPS receiver will be stored against the smart card number in the Arm Processor and when he exits the bus, the passenger swipes the card again.

(iii) GPS gets the location coordinates of exit point and the Arm Processor calculates the distance travelled and fare.

(iv) GPS also records the speed of the bus. If the bus exceeds the speed limit the buzzer in the bus beeps to indicate the driver about his violation.

(v) Even then if the speed is not reduced the messages regarding speed violation is sent to the control room.

IV. RESULTS AND DISCUSSION

The results obtained during the construction states after necessary troubleshooting were satisfactory .the system was able to respond to its operations of calculating, displaying and detecting the amount, speed and location which results in fully functional module.

We have done quite a work in designing simple yet efficient device for the ease of users.

Here we have considered the following locations in vidhyavardhaka College of engineering.



Fig 4 (a) Location 1



Fig 4 (b) Location 1 display

Fig 4 (a) and Fig 4 (b) shows the first location considered for tracking the location of the bus. Here the LCD display shows the location considered.



Fig 4 (c) Latitude and Longitude

Fig 4 (c) shows the location latitude and longitude detected by GPS.



Fig 4 (d) First swipe

Fig 4 (d) shows the amount and the balance available in the RFID card initially.



Fig 5 (a) Location 2



Fig 5 (b) Location 2 display

Fig 5 (a) and Fig 5 (b) shows the second location considered for tracking the location of the bus moved. Here the LCD display shows the location considered.



Fig 5 (c) Latitude and Longitude

Fig 5 (c) shows the location latitude and longitude detected by GPS.



Fig 5 (d) First swipe

Fig 5 (d) shows the previous balance amount and the deduction amount after first swipe



Fig 5 (e) Second swipe

Fig 5 (e) shows the balance amount after the first swipe and the same amount as the balance if the RFID card is swiped twice.

Message replies to the passengers by considering Vidhyavardhaka college of engineering campus as an example

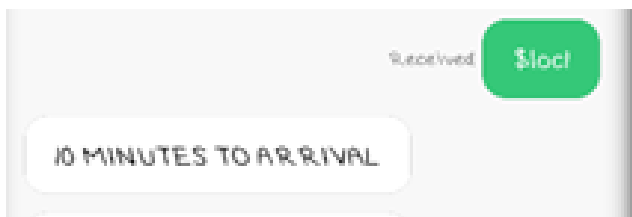

Fig 6 (a) Message reply when the bus is at Location 2

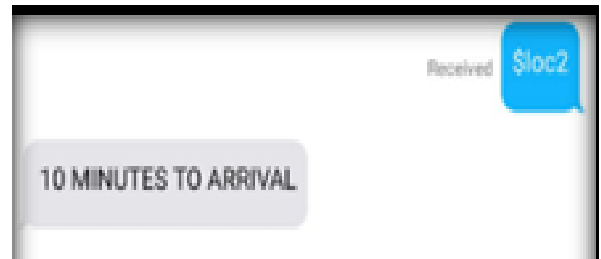

Fig 6 (b) Message reply when the bus is at Location 1

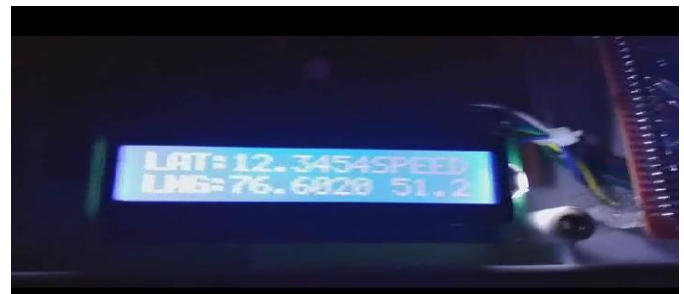

Fig 5(h) overspeed detection

Fig 5(h) shows Buzzer beeping after the bus cross threshold limit of 50km until the speed becomes less than the threshold limit.

ie, example: Threshold limit is 50km



Fig 5(i) Speed of the bus initially

V. CONCLUSION

The limitations of the existing system have been rectified by making it more automated, reliable, transparent and convenient. This can be implemented in a large scale at metropolitan cities in India.

Fare is debited from RFID tag as the tag is rechargeable. We propose the RFID based tickets for its low cost, easy operation, portability, durability, reliability and being much more user friendly. Also the high speed RFID tags and detectors make the tracking system of a moving bus merely a child's play.

III. FUTURE WORK

In future, the system will enhance to provide more accurate estimated arrival time to user. There are many other enhancements for the proposed system, one of the important enhancement would be create an artificial intelligence program to automatically study and analysis bus route data to provide most optimum estimate arrival time. By applying artificial intelligence program, the system will become more valuable because of the accuracy of estimation on arrival time.

REFERENCES

- [1] Dr. Prasun Chowdhury & et.al., "RFID and Android based smart ticketing and destination announcement system", 2016 Intl.conference on advance in computing, communications and information's(ICACCI),Sept. 21-24,2016.
- [2] Roman Khoeblel & et.al., "Passenger monitorin model for easily accessible public city trams/trains", 978-4799-7961-5/5,205 IEEE
- [3] Mohammad shahid & et.al., "Digital speedometer with password enabled speed limiting feature", international journal of trend research and development, volume 3(3),ISSN:2394-9333
- [4] Safa Abd elmonem & et.al., "Design of bus tracking and fuel monitoring system", 207 international conference on communication, control, computing and electronics engineering(ICCCCEE)
- [5] Nalawade.S.R. & et.al., "Bus tracking by computring cell tower information on Rasperry Pi",2016 international conference on global trends in signal processing, information computing and communication,978-1-5090-0467-6/16,2016 IEEE.