

Review of Harvesting of RF and Human Heat Energy

K Namana Shenoy
Student
Department of Telecommunication,
DSCE, Bengaluru-78

Drishya Jayan,
student
Department of Telecommunication,
DSCE, Bengaluru-78

Dhana Lakshmi L
Student
Department of Telecommunication,
DSCE, Bengaluru-78

Ayushi
Student
Department of Telecommunication,
DSCE, Bengaluru-78

Vivek Raj K,
Assistant Professor
Department of Telecommunication,
DSCE, Bengaluru-78

Abstract:- In this paper various efficient energy harvesting technique is discussed. Radio frequency (RF) energy and the human heat energy are the two energy forms that is being harvested. Different modules and techniques are being studied to harvest the energy efficiently without any side effects to the environment, thus involving the green technology concept. This concept deals with clean harvest of energy resources to yield efficient output. The output obtained can be used for various low power applications

Keywords:- Harvest, radio frequency (RF), human heat, efficient, green technology.

I. INTRODUCTION

In the present scenario there is an urgent need to switch on to alternative methods to harvest energy since the natural resources are getting depleted by the consumption rate increasing to great extent. These exhausted natural resources take prolonged time to regenerate, so using alternative techniques for harvesting energy can be conducted.

When we say alternative methods, the sources can be heat, light, wind, thermal, RF etc. which are present in the ambient surroundings. Solar energy harvesting is quite expensive to install and working is sensitive to the climatic change. Wind energy harvested by installing of windmills in wind prone areas have a disadvantage of space consumption and expensive setup.

Having these drawbacks now the focus was to harvest with minimal cost, hence harvesting of RF energy using a suitable antenna module followed by certain other blocks to produce energy is implemented. This is less expensive compared to solar and wind, and not much space is needed for these modules.

Humans often prefer harvesting techniques such that he is not compelled to change his habits to generate energy. Instead, the power is harvested from his daily actions which is known as Passive harvesting technique. The supply of power for these should be maintenance free and regular. Even though batteries are usually our first choice as it is exhaustible it's not preferred. That's how thermoelectric generators started being used. Human heat

harvesting is also a technique which can generate energy at less expense, without causing any harm to the environment. This makes use of a thermoelectric generator module which works on peltier effect. This is an effect where in heat is absorbed or given out when an electric current passes through the junction between two materials.

II. RF AND HEAT ENERGY HARVESTING

There are various sources in our surroundings that can be harvested to generate energy, like wind, heat, light, RF etc. Among these, harvesting of RF signal and human heat, which are the ambient source present in the environment is focused as the methods used in those harvests are clean and non-polluting the surroundings. RF energy harvesting has another advantage that it is time invariant and independent to seasonal changes.

The energy generated from both RF and human heat harvesting is a few volts which is used to power up low power devices or can be stored in some super capacitors. There may be requirement of using voltage booster, which is dealt in following section. Module used in the harvest is mobile hence adding on as an advantage to be applicable for use in various areas.

III. RECEIVING ANTENNA

An antenna acts as a transceiver that is both as a transmitter and a receiver. In RF energy harvest an antenna is a important element which is used to capture the RF signals of various desired frequencies as per the requirement. There are varieties of antenna types available, some of which are dipole, patch, horn, yagi-uda, parabolic etc. but patch antenna is the most widely used. This is so because it is simple to fabricate different shaped patches, has low profile which means to say minimal height of antenna about few millimeters from the ground (width).

Various constraints are to be considered for the designing of an antenna. The antenna designed must have higher gain which indicates good receiving quality of the antenna. In order to increase the gain array of antennas can be designed. Substrate thickness matters a lot as more the

thickness more bandwidth obtained and thinner the substrate bandwidth reduces [1]. Bandwidth specifies the range of frequency at which the antenna will work efficiently.

Microstrip antennas are made by depositing a copper layer of desired antenna shape on a substrate material whose base is made up of copper called as ground. Reason behind selecting microstrip patch antenna is due to their certain characteristics such as light weight, small in size when compared to old models of antenna and cost effective when produced in mass.

The receiving antenna is followed by a filter and rectifier circuit. Filter circuit is used to filter out the unwanted frequency signals and tune to obtain only the desired noise free signal. This AC signal is converted to DC using a rectifier circuit made up of main element diode which is a unidirectional device.

IV. THERMOELECTRIC MODULE

This module is based on Seebeck effect. In this heat flows from warmer side to colder side and this leads to movement of electrons or holes giving rise to current. It works when there is a temperature difference of 300°C – 400°C .

TEG modules typically consist of semiconductors, usually being bismuth telluride. It includes many leg pairs of semiconductor pellets. These legs are sandwiched using aluminum sheets and to reduce heat loss, module is surrounded by PDMS.

This provides an efficiency η when heat is being converted to electric energy.

$$P = \eta Q$$

It is based on size of heat exchangers that harvest heat from warmer side and discard from colder side that Q i.e. quantity of heat depends[2].

These are placed in different parts of the human body like wrist, palm, forehead, thighs and for human convenience, size of the module is reduced. Thus, making it a portable device [3]. As this harvesting technique provides very low output we have to make use of voltage multiplier circuit in order to boost it.

V. VOLTAGE MULTIPLIER

The voltage obtained from the antenna is of very less value i.e. few microvolts to millivolts. Hence this voltage, which is insufficient to energize low power devices, can be boosted using voltage multiplier circuit. The incident AC voltage from the antenna is converted to DC voltage at the output of the multiplier circuit. A simple voltage multiplier circuit consists of diodes and capacitors. This can be composed as one stage. Many such stages can yield more amount of output voltage. The selection of capacitors are done based on the frequency range at which the antenna operates. Higher number of voltage multiplier stages gives out higher voltage but also delay in charging of capacitor may occur [4]. With DC as an input to the multiplier

circuit, an inductor is connected along with the components discussed above.

There are types of multiplier circuits such as, Villard voltage multiplier (Figure 1) and Dickson voltage multiplier (Figure 2). The Villard voltage multiplier also called as Cockcroft-Walton voltage multiplier converts low voltage level of AC to a higher voltage level of DC. The significance of the circuit is that the voltage across each cascaded stage is equivalent to double the peak voltage at input in a half wave rectifier. The Dickson voltage multiplier provides reduced power conversion efficiency due to the voltage drop at the input because this voltage across transistors, compared to voltage at output, is more significant. The topology design of the two circuits do not have any varied difference in the performance.

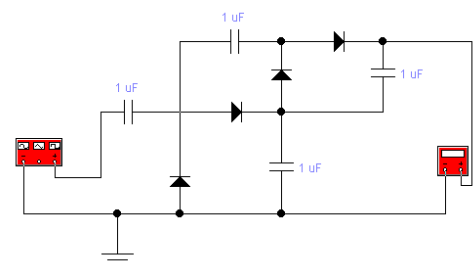

Figure 1. Villard voltage multiplier

The multiplier design, simulated using Multisim software with the usage of Schottky diode- HSMS2850, is a 7 stage voltage multiplier circuit. This particular diode has many advantageous features such as non-symmetric properties of diode, fast switching, forward voltage is less, and leakage of substrate is also less. With RF range at the input end at 945 MHz approximately, of GSM 900 band, the output voltage at the last stage is obtained for an input

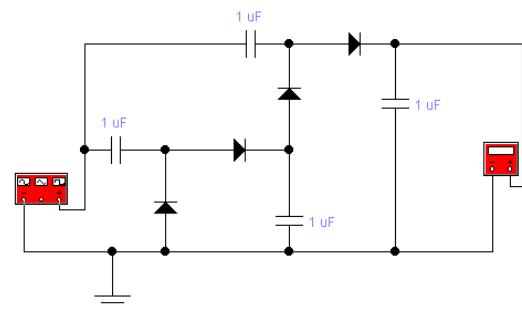

Figure 2. Dickson voltage multiplier circuit

power ranging from -40 dBm to +5dBm, with an input impedance value of the circuit as 63-j117Ω. Results shows that the practical circuit has given out more output voltage compared to the simulated circuit because the diode’s resistance value may be less practically than in simulated circuit. Hence the discharging speed of the capacitor also increases eventually, thus making the voltage directly available at the output at a faster rate. The results shows that the voltage measured at the output do not multiply or

double after the 7th stage. The voltage does not exceed after certain level, which remains same after the stage 7 [5].

VI. CONCLUSION

Various sections such as RF and heat energy harvesting, receiver antenna, thermoelectric module and voltage multiplier required for harvesting energies are discussed above. These sources are advantageous over other renewable sources. On the whole around 5V can be extracted from these sources, which has been used to energize the low power devices.

VII. REFERENCES

- [1] Esraa Ali, Perumal Nallagownden, M. A. Zakariya, "Design of microstrip patch antenna at 900MHz for charging mobile applications", Medwell journals 2017.
- [2] P Mahalakshmi, S Kalaiselvi, "Energy harvesting from human body using thermoelectric generator", IJAREEIE 2014.
- [3] G. Jeffrey Snyder, "Small thermoelectric generators", 2008.
- [4] Kaushik Roy Chowdhury, David Richard Lewis, "Design optimization and implementation for RF energy harvesting circuits", IEEE journal 2012.
- [5] C. K. Chakrabarty, N.M. Din, "Design of RF energy harvesting system for energizing low power devices", 2012.