

# Review of Advances in Robotic Arm Design

<sup>1</sup>Shrihar Pandey, <sup>2</sup>Vikash Singh, <sup>3</sup>Rajvendra Singraul, <sup>4</sup>Sumit Thakur, <sup>5</sup>Ankit Rajak,  
<sup>6</sup>Mohit Namdev, <sup>7</sup>Subhankar Pandey, <sup>8</sup>Brijesh Kushwaha.  
<sup>1</sup>Associate Professor, Department Mechanical Engineering,  
<sup>2,3,4,5,6,7,8</sup>. Student, Department Mechanical Engineering,  
AKS University, Satna, Madhya Pradesh, India

**Abstract - Robotic arms are widely used in modern automation systems across various industries such as manufacturing, healthcare, and hazardous environment handling due to their precision, flexibility, and efficiency. This paper presents a comprehensive review of recent advancements in robotic arm design, control systems, and applications. Various configurations of robotic manipulators, along with material selection, degrees of freedom (DOF), and kinematic considerations, are discussed. In addition, different control strategies including haptic control, programmable logic control (PLC), and intelligent control techniques are analyzed. The study also highlights key challenges such as high cost, complexity, and limited adaptability. Finally, future research directions focusing on artificial intelligence-based control systems, lightweight materials, and improved human-robot interaction are presented.**

**Keywords:** robotic arm, haptic technology, motor, degrees of freedom (DOF).

## 1. INTRODUCTION

Robots are being used more and more in the workplace these days, especially for tasks that need to be done over and over again. There are two main types of robotics: industrial and service robotics. The International Federation of Robotics says that a service robot is one that works on its own or with some help to do tasks that are good for people and machines, but not for making things. These robots are now used in a wide range of fields, such as the military, hospitals, dangerous environments, and agriculture. Also, it might be hard or dangerous for people to do certain things, like picking up explosive chemicals, defusing bombs, or, in the worst case, picking up a bomb and putting it somewhere safe so it can be picked up and put down again and again in factories.

**Robotic arm** definition: A robotic arm is a robot manipulator, typically programmable, with functions similar to a human arm. The segments (links) of the manipulator are connected by joints that allow either

rotational motion (as seen in articulated robots) or

translational (linear) displacement. These links form a kinematic chain. The business end of this kinematic chain is called the end effector, which is analogous to the human hand. End effectors can be designed to perform various tasks such as welding, gripping, or spinning, depending on the application. Robotic arms can operate autonomously or be manually controlled, performing a wide range of tasks with great precision. They may be fixed in place or mobile (e.g., wheeled) and can be designed for industrial or home use.

## 2. LITERATURE SURVEY

1. Design Analysis of a Remote- Controlled Pick-and-Place Robotic Vehicle: robotic vehicle. The system is functional and aims to reduce human risk when handling suspicious or hazardous objects. It enables complex and complicated tasks to be performed faster and more accurately.
2. Robotics Arm Control Using Haptic The paper discusses a robotic arm system controlled through real-world haptics. Haptic guidance helps users learn complex motion skills by providing tactile cues. The system has potential applications in both critical fields and leisure, emphasising the need for smaller, lighter, and easier-to-use haptic devices. Haptic technology enables real- time interaction with virtual objects.
3. A Review on Robot Arm Using Haptic Technology  
*Prof. A. Reshamwala, R. Singh* This paper explores the control of robotic arms using haptic technology, focusing on a 3-DOF robot arm operated with minimal resources. The system aims to be user-friendly for disabled individuals. Future enhancements include obstacle detection and image processing integration.
4. Design and Operation of Synchronized Robotic  
*Goldy Katal, Saahil Gupta* robotic arms capable of performing tasks such as welding, gripping, and spinning. Examples include automotive assembly. line robots that handle tasks like welding and part

rotation/placement.

- Design and Implementation of a Robotic Arm Based on Haptic Technology: This research focuses on designing a robotic arm using haptic technology, highlighting its industrial and medical

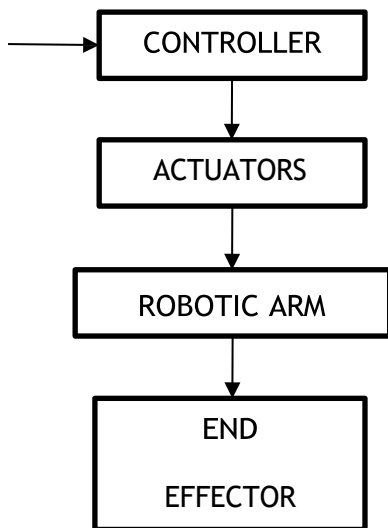

applications (e.g., pick-and-place and surgical robots). The paper stresses the importance of precision and accuracy, especially in areas inaccessible to human hands.

- Haptic Control Development of Robotic Arm: Mohamoud A. Hussein. A master-slave system with force feedback was developed, using LabVIEW and Arduino for control and inverse kinematic calculations. The system effectively displays interaction forces, demonstrated through human input on soft tissues of varying stiffness.
- Design of a Robotic Arm with Gripper & End Effector for Spot Welding, Puran Singh  
 This study involved designing a LabVIEW- controlled robotic arm with integrated accelerometer feedback. The system is user-friendly and capable of precise real-time control.
- Design and Analysis of an Articulated Robot Arm for Various Industrial Applications  
 The paper uses strength of materials principles and models hollow cross- sections with SolidWorks and ANSYS for stress analysis. Circular cross-sections are preferred due to manufacturability.

ease of transport, and weight considerations.

- Design and Development of Search and Rescue Robot: Khalil Azha Mohd Annuar, Muhammad Haikal Md Ziii  
 This research presents a mobile robotic vehicle with a four DOF robotic arm, controlled via mobile devices, designed for search and rescue missions. A graphical user interface (GUI) enhances usability.

- Survey  
 This survey discusses various parameters affecting robotic arm performance, such as degrees of freedom (DOF), working envelope, kinematics, speed, accuracy, and repeatability. It highlights research gaps and suggests future improvements through effective algorithms and simulations.

### 3. DESIGN TECHNIQUE :

- Block Diagram:
- DOF DIAGRAM

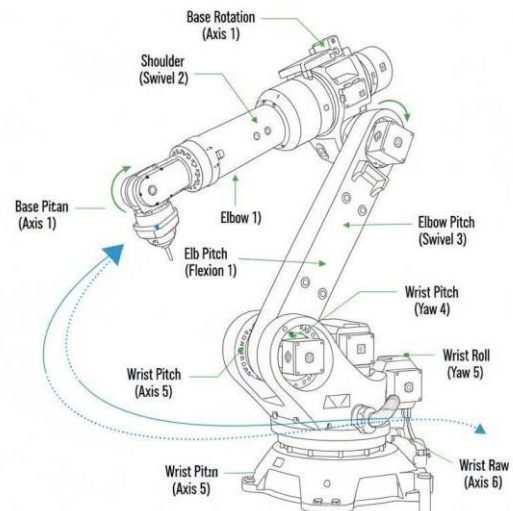

ROBOTIC ARM: DEGRES OF FREDDOM AND MOTION TRAJECTORY

- control state diagram of reconfiguration:
  - As noted previously, the key to competitiveness in today's global market lies in the ability to respond quickly to change while maintaining stable system operation and efficient use of available resources. In the manufacturing domain, there has been growing interest in intelligent control to address this challenge.
  - Research has shifted away from traditional, monolithic,

centralised control systems toward distributed architectures. These architectures range from hierarchical to non-hierarchical structures, involving multiple decision-makers.

3. Distributed intelligent control aims to align the control model more closely with the physical system. This approach is especially relevant for manufacturing control systems, which must manage widely distributed devices in environments prone to disruptions. Control in such systems is achieved through the emergent behaviour of many simple, autonomous, and cooperative entities called 'agents'. These agents make local decisions independently rather than relying on a central controller.

#### 4. CONCLUSION:

This paper reviewed various robotic arm designs and control strategies. It was observed that recent developments focus on intelligent control systems, lightweight materials, and enhanced human-robot interaction. However, challenges such as high cost and complexity remain. Future research should focus on AI-based adaptive control systems and cost-effective robotic solutions.

#### 5. REFERENCE:

- [1] Design Analysis of a Remote Controlled Pick and Place Robotic Vehicle by B.O. Omijeh (International Journal of Engineering Research and Development e-ISSN: 2278-067X, p-ISSN: 2278-800X, [www.ijerd.com](http://www.ijerd.com) Volume 10, Issue 5 (May 2014), pp. 57-68)
- [2] ROBOTICS ARM CONTROL USING HAPTIC TECHNOLOGY by Vipul J. Gohil (International Journal of Latest Research in Science and Technology ISSN (Online): 2278-5299) Volume 2, Issue 2: Page 98-102, March - April (2013)
- [3] A Review on Robot Arm Using Haptic Technology by Prof. A. Reshamwala and R. Singh (International Journal of Advanced Research in Electrical, Electronics and Instrumentation Engineering) Vol. 4, Issue 4, April 2015.
- [4] DESIGN AND OPERATION OF SYNCHRONIZED ROBOTIC Katal, Saahil Gupta (International Journal of Research in Engineering and Technology) Volume: 02 Issue: (08 Aug 2013)
- [5] Design of a Robotic Arm for Picking and Placing an Object Controlled Using LabVIEW by Shyam R. Nair (International Journal of Scientific and Research Publications, Volume 2, Issue 5, May 2012)
- [6] Chavdarov I, Yovchev K, Naydenov B, Hrosinkov V (2024). 3D-printed robotic arm. International Conference on Software, Telecommunications and Computer Networks (SoftCOM), pp. 1-6.
- [7] Eaton M, Tanveer MH (2024). The development and implementation of a cost-effective educational robotic arm using ROS-MoveIt. In 2024 IEEE Integrated STEM Education Conference (ISEC), pp. 1-4.
- [8] Cehovin Zajc L, Rezelj A, Skořič D (2023). Low-cost open-source robotic platform for education. IEEE Trans Learn Technol 16(1):18-25.
- [9] Grubišić V, Crnokić B (2024). A systematic review of robotics' transformative role (Vasić, Vasić, and D (eds.)). Digital Transformation in Education and Artificial Intelligence Application. Cham, Springer Nature Switzerland, pp. 257-272.
- [10] Krimpenis AA, Papapaschos V, Bontarenko E (2020). Hydrax, a 3D-printed robotic arm for hybrid manufacturing. Part I: Custom design, manufacturing and assembly. Procedia Manuf 51:103-108. 30th International Conference on Flexible Automation and Intelligent Manufacturing (FAIM2021).
- [11] Lee R, Usaquen J, Martínez F (2024). Development of low-cost stereoscopic vision systems for educational robotics: A state of the art. Global J Eng Technol Adv 20(01):001-009. Received on 16 May 2024; revised on 25 June 2024; accepted on 28 June 2024.
- [12] Martínez A et al. (2023). Design and implementation of a robotic arm for a mocap system within an extended educational mechatronics framework. Mach 11(3):281.
- [13] Papapaschos V, Bontarenko E, Krimpenis AA (2020). Hydrax, a 3D-printed RT II: Control, calibration and programming. Procedia Manuf 51:109-115. 30th International Conference on Flexible Automation and Intelligent Manufacturing (FAIM2021).
- [14] Surynek P (2024). Real Robot One (RR1): 3D-printed robotic arm for teaching robotics engineering and robot control. In 2024, 9th International Conference on Control and Robotics Engineering (ICCRE), pp. 33-38.
- [15] Tselegkaridis S, Sapounidis T (2021). Aerobot: A low-cost educational robot for STEM education. J Educ Robot 9(2):56-68.
- [16] Tselegkaridis S, Sapounidis T (2022). Exploring the features of educational robotics and STEM research in primary education: A systematic literature review. Educ Sci 12:305.
- [17] Uslu A et al. (2022). Trends and research foci of robotics-based STEM education: A systematic review. Int J STEM Educ.
- [18] Weeraratne A, Subasinghage K (2024). Comparison of open-source robotics platforms for undergraduate education. In 2024 International Research Conference on Smart Computing and Systems Engineering (SCSE), vol. 7, pp. 1-5.