

# Quality Improvement of the Front Loading Washing Machine using Concept of Design

Susheel Singh Kshatriya<sup>1</sup>  
<sup>1</sup>M.Tech Student  
VITS Satna,  
M.P., India-485001

Diplesh Gautam<sup>2</sup>  
<sup>2</sup>Assistant Professor,  
Department of Mechanical Engineering,  
VITS Satna, M.P., India-485001

**Abstract**—There is a challenge of improving the eco-efficiency of the front load washing machine by reducing water consumption. The best solution was determined to implement a filtration system to clean and reuse water between each of the load cycles from the rinse3 drain water. Laboratory testing was performed on polypropylene and activated carbon filters in a total filtration (dead-end) configuration to provide proof of concept for the prototype. The prototype system was designed using two dead-end filters: polypropylene and activated carbon. Due to lifetime and Ph values issues with the activated carbon filter, a final filtration system was proposed by using polypropylene filter. The final design will replace the Activated carbon filter with one more polypropylene cross-flow filter to allow for easy self-cleaning maintain flow rate and prolonged lifetime.

**Keywords**—Washing Machine, activated carbon filter, pH, TDS, Polypropylene filter

## I. INTRODUCTION

India uses more than 808 billion gallons of water each year to do laundry [1]. Therefore, there is tremendous room for improvement in the fabric care industry. The Whirlpool Corporation has proposed the design problem of improving the eco-efficiency of the Whirlpool Duet fabric care front-loading washer. On the same basis with new concepts if we redesigned our existed front loading washing machine with reduced water emissions will enable IFB Industries Pvt. Ltd to remain one of the most innovative companies in the appliance market. The major goal was to reduce the water consumption while maintaining washer performance and keeping the additional costs under Rs 900. If the redesign is successful the water-efficient machine will appeal to environmentally friendly consumers and customers in regions where water shortages often occur.

Washing machine is a machine that quickly washes clothes, linens and other items. Before the invention of the washing machine, people spent hours doing their laundry by hand. Some people soaked their clothes in streams and then beat them with rocks to get out the dirt. Later, people scrubbed their laundry on washing boards. Also people on sea voyages washed their clothes by placing the dirty laundry in a strong cloth bag, and tossing it overboard, letting the ship drag the bag for hours. This principle of forcing water through clothes to remove dirt has been used by people for many centuries and the modern washing machine can be considered an evolutionary advancement of this technique. All the important parts of

the washing machine are electrically controlled, including the inner drum, the valves, the pump, and the heating element. Set the program you want and switch on the power. There are basically three steps in a wash cycle: washing, rinsing and spinning. There is usually 1 complete fill/drain for the washing step and 3 complete fills/drains for the rinsing step. During the washing step, the programmer first opens the water valves so hot and cold water enters the machine and fills up the outer and inner drums. The water usually enters at the top and trickles down through the detergent tray, washing any soap there into the machine. The programmer switches off the water valves. The thermostat measures the temperature of the incoming water. If it is cold, the programmer switches on the heating element. When the water is hot enough, the programmer makes the drum rotate back and forth, sloshing the clothes through the soapy water. The detergent pulls the dirt from clothes and traps it in the water. The programmer opens a valve so the water drains from the drums. Then it switches on the pump to empty the water away. After the washing step, the washing machine begins rinsing. The programmer opens the water valves again so clean water enters the drums. The programmer makes the drum rotate back and forth so the clean water rinses the clothes. It empties the drum and repeats this process 2 times to get rid of all the soap. When the clothes are rinsed, the programmer makes the drum rotate at high speed—around 1000 rpm, the clothes are flung against the outside of the drum, but the water they contain is small enough to pass through the drum's tiny holes. This is how spinning gets your clothes dry. The pump removes any remaining water and the wash cycle comes to an end.

## II. OBJECTIVE

In an effort to improve the eco-efficiency of IFB Washing Machines, IFB Industries Pvt. Ltd, is interested in developing a more water efficient washing machine. Thus, they assign a project to us to explore solutions to reduce the water usage of the IFB front loading washing machine by 25-30% without significantly increasing energy usage and cost. Collaborating with IFB officials and BITS mentors we have conceived to build a prototype of a filtration system that recycles rinse water for reuse rather than disposing it after each cycle. Our team was responsible for the design of the filters and also for the

overall design. This poster outlines the process and results of the design and fabrication of our prototype.

As part of the design process, we were asked to undergo concept generation, concept evaluation, and ultimately select a final design. Our design must meet the technical specifications set forth by IFB and maintain the exceptional wash performance and strict safety guidelines. The final design is a washing machine which consists of a water recirculation system and filtration device. The project concluded with a design proposal that will lead to a working prototype.

### III. LITERATURE REVIEW

#### *General Principle of Front Loading Washing Machine [1] Parts of a Front Loading Washing Machine:*

The most important parts of a washing machine are inner drum and outer drum. The inner drum is the one you can see when you open the door or the lid. You push your clothes inside the door from the front and the whole drum rotates. The drum has lots of small holes to let water in and out and paddles around the edge to slosh the clothes around. The outer drum is the bigger drum outside the inner drum. Its job is to hold the water while the inner drum rotates. Unlike the inner drum, the outer drum has to be completely water-tight.

Besides the two drums, there are lots of other components. There's a thermostat (thermometer mechanism) to test the temperature of the incoming water and a heating element that warms it up to the required temperature. There's also an electrically operated pump that removes water from the drum when the wash is over. There's a mechanical or electronic control mechanism called a programmer, which makes the various parts of the washing machine go through a series of steps to wash, rinse, and spin your clothes. There are two pipes that let clean hot and cold water into the machine and a third pipe that lets the dirty water out again. All these pipes have valves on them.

#### *Layout and Analysis of Existing Washing Machine*

With the basic understanding of how a front loading washer works, we could then analyze the system we were provided by IFB. This section of the literature search provides research on the Washing Machine system and how it works and is designed.

*Consumer Services Manual:* This manual outlined many of the technical specifications of the washing machine. It gave all of the dimensions, power inputs, temperatures, wiring diagrams, and component descriptions. It also gave detailed descriptions of all of the washer subsystems and what components were involved and how they all functioned. Based on this manual, we could put hard numbers to many of our requirements by using the existing system as a benchmark. [2]

*Duet Washer Schematics:* These schematics allowed us to examine several subsystems to see how components connected and where we might be able to modify the washer to include our system. Areas of special interest were the drain and pump system and the washer tub and basket system. These schematics may also be used should we decide to disassemble the washer to examine its

#### *Metrics of Wash Quality*

In order to determine the effectiveness of the filtration system after the prototype has been created, a method of quantifying the quality of the washing process needs to be established. It was determined that the two most useful ways of doing this would be to measure the cleanliness of the water after it passes through the filtration system and the cleanliness of a load of clothes after they have gone through the complete washing process with the filtration system in place. The cleanliness of the water would be compared to that of the water entering the washer from an external source and the cleanliness of a load of clothes would be compared to that which the current, unmodified washer produces.

*Cleanliness of Water:* Methods for quantifying the cleanliness of water were researched and many different ways were discovered. The Pacific Northwest Pollution Prevention Resource Center (PPRC) [8] lists a variety of methods to detect the presence of bacteria, chemicals, and solid particles in water. However, many of the methods such as optically stimulated electron emission, direct oxidation carbon coulometer, x-ray photoelectron spectroscopy, and ultraviolet spectroscopy, while very accurate, require equipment that is expensive and not readily available. Other methods, like magnified visual inspection and the water break test, are much simpler to perform, but only produce —pass/fail results (i.e. The water is either contaminated or it's not). This is not useful because it would make it difficult to analyze and compare test results against each other for effectiveness. Also, the water may not necessarily need to be completely free of contaminants to be considered acceptable. The PPRC also suggests gravimetric measurements which involve removing solid particles from the water through filtration, solvents, or drying the water out over a surface and weighing them on a highly sensitive scale. This was considered as a viable option. Another method that was researched was measuring the turbidity of the water. Turbidity is the amount of suspended particulate in a fluid that causes a decrease in the passage of light. Turbidity can be measured in nephelometric turbidity units using a turbid meter. Measuring turbidity is simple, requires accessible equipment, and is accurate enough that the effectiveness of the filtration system can be closely monitored by comparing test results. This method was considered the most useful out all that were researched. Therefore, it was concluded that measuring turbidity, perhaps in conjunction with the gravimetric measurements, is the best way to measure the cleanliness of water in this system.

*Cleanliness of Clothes:* After much research, it was discovered that little has already been accomplished in the way of quantifying the cleanliness of clothes. The most relevant method found is the —PBIS| method that was adopted by the Australian Standards Committee in February 2005 [9].

### IV. PROBLEM STATEMENT

Task is with developing an eco-efficient washing machine with a goal of reducing wash cycle water usage. In order to meet this goal, we are researching new technologies in the

fields of Recirculation of water and Filtration device. We were worked on the project and perform the tasks of brainstorming potential designs and decide the best design as defined by IFB criteria. Water scarcity in India increases day by day with increase in consumption of water in daily life and use of it for fabric cleaning in domestic and industries increases this water shortage drastically. Due to the limited time scope of the project, one of the challenges is in selecting the proof of concept for a filtration system to reduce water consumption while minimizing additional energy consumption. This reduction in water consumption must not forgo the quality of the wash. In addition, the system must fit within the confines of the pedestal accessory and allow for attachment into the washer system. Various issues in recirculation of drain water and reuse it in during load cycles occur like to maintain flow rate, water turbidity, cleanliness, soap content and biological content in recirculated water. Design of Prototype and its Lab Test validation is one of the challenges to find the appropriate solution for the above mention problem.

**Function of the Product**

The main function of the project is to minimize the Water consumption in IFB Front loading Washing Machine also to clean the water for recirculation in washing machine cycles. For this the filters are to be design to deal with removal of detergent from the water, reduce turbidity of water and it should also maintain the pH level of recirculated water. Function of the product is shown by the layout diagram in Fig.4.1

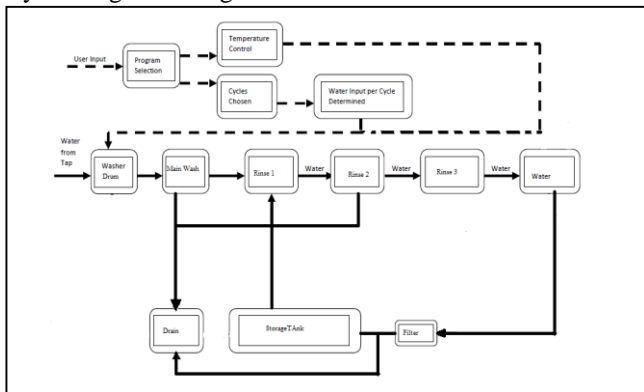

Fig.4.1 Function Diagram

**Possibilities**

Reuse of rinse water, specially the rinse 2 and rinse 3 cycle’s water is having small deviation from the pH level of neutralized water and it is less contaminated also.

**Benefits**

If we only save rinse 3 cycles water i.e. 17 (approx.) litre of water, then annually we can save around 3000 litres of water. There are possibilities to clean the rinse 2 cycle water also, and if it happens then the water consumption will lead to almost half that is required now.

**Compiled Customer Needs:**

- Ergonomically designed
- Less water Usage

- Last long and easy to maintain
- Compact in size
- Low cost
- Light weight
- Aesthetically good
- Require less part for assembly
- Easy assembly & dismantling during replacement
- System drain time
- Clean water
- Robust filter unit
- System fit

**Quality Function Diagram**

The project requirements were examined in more detail and relative importance levels were assigned based on the market demands and the customer needs as per the customer survey feedback. These importance levels were related using a Quality Functional Diagram (QFD). The QFD combines customer demands with their importance weights with the translated engineering specifications to determine the most significant aspect in the product development of the new IFB system. In the QFD, it is seen that the filter material and size is the most important technical requirement with an importance percentage of 30% as seen in Table 4.2.

Table 4.2.

Customer Needs	Customer Weights	Dimensions	No. Of Parts	Total Cycle Time	Durability/Strength	Filter Capability	Filter size	Water Us usage
Water Reduction	4	3	3				3	9
System Drain Time	3		1	3			3	
Hot/Cold Rinse Water	4				9	3	9	
Clean Water	4				9	3	9	
Robust Filters	4				9		9	
System Fits	3	9	9					
Affordable	2	3	9				9	
Easy To Manufacture	3	9	9		3			
No Leakage	4	3	3		9			1
	Raw Score	69	90	9	93	48	147	40
	Scaled	0.47	0.61	0.06	0.63	0.3	1	0.27
	Relative Weight	14%	18%	2%	19%	10%	30%	8%
	Rank	4	3	7	2	5	1	6

### V. CONCEPT GENERATION

In investigating ways to meet our design goal, we came up with various conceptual ideas focused entirely on reducing the amount of water in the wash cycle. To do so, we explored the logistics of the wash cycle, and divided the concepts into distinct categories describing the subsidiary functions of the design. These functions are outlined in following Morphological Chart shown in Figure.4.3 Note that this Morphological Chart has been adapted from their traditional purpose to fit the needs of our team. Rather than using it to define various subsystems, we plan to use it to generate potential ideas and designs. This chart provided a broad representation of all the feasible design options available for integration into the washer system

Water from Alternate Sources	Capture Air Humidity	Use Condensed Water from the Dryer Air Output	Reuse Household Water	
Utilize Unconventional Fluids	Low Sudsing Detergent	Advanced Enzyme Detergents		
Recycle Water	Recirculation Looped System	Reverse Osmosis Water Filtration	Surfactant Water Filtration	Incorporate Holding Tank
Decrease Water Intake	Decrease Water Per Cycle	Decrease Wash Cycle Time	Improved Sensors	
Better Utilize Water in the Wash Cycle	Incorporate Spray Jets	Heat Water to a Higher Temperature	Incorporate Steam Cleaning	
Redesign Conventional Mechanical Components	Redesign Agitator			

Figure no5. Morphological Chart outlining our design concepts

#### Concept Generation for Final Product

##### Concept no.1

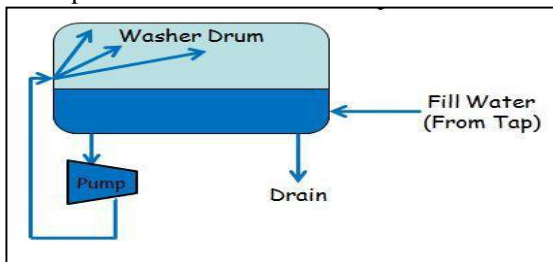

Fig. no 5.1 Concept no.1

##### Concept no.2

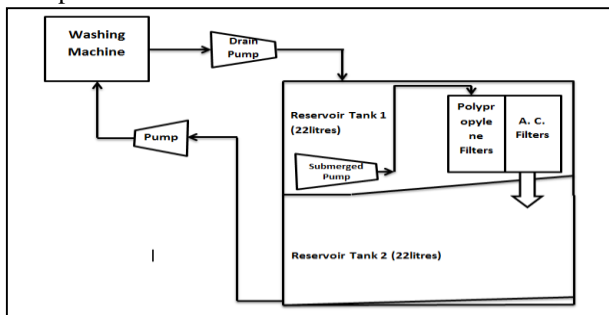

Fig. no 5.2 Concept no.2

##### Concept no.3

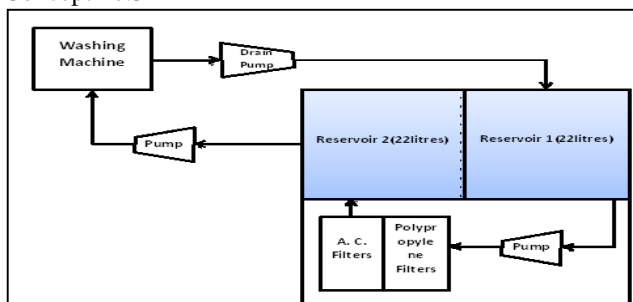

Fig. no 5.3 Concept no.3

##### Concept no.4

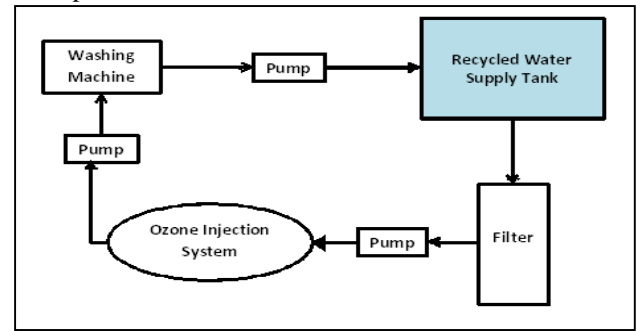

Fig. no 5.4 Concept no.4

##### Concept no.5

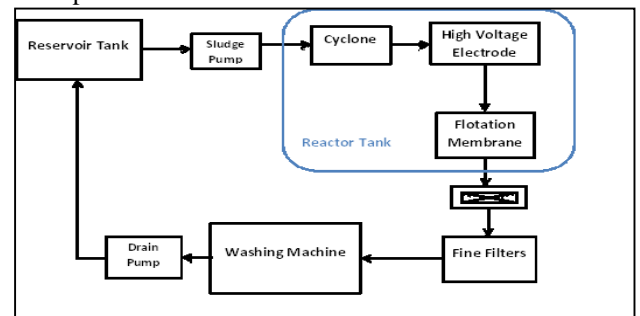

Fig. no 5.5 Concept no.5

#### 5.1 Concepts Selection

In product development, we as a development team can be thought of as having three tasks, gathering information, making decisions and disseminating information. Now task is how the gathered information is transformed and implemented and also facilitate the forming of a critical aspect of a development process, i.e. team consensus (an opinion or position reached by a group as a whole).

The selection process is a five step process plus iterations:

- Forming consensus on the criteria
- Forming consensus on the alternative.
- Ranking alternatives
- Evaluating alternative
- Attacking the negatives.

The above discussed process can be applied with decision making tools as developed by Pugh.

These tools known as Pugh charts, use minimal evaluation scale and ranking matrices.

Pugh charts are the most effective known tools for preliminary concept screening when there is minimal information quality available. They are also effective as the information quality increases and the selection scale is refined. The goal of any selection process is to obtain as much information and concept details as cycle time and resources permit.

*Pugh's Concept Screening Matrix*  
 Table no.5.1

S No	Selection Criteria	Concept1	Concept 2	Concept 3	Concept 4	Concept 5
1	Life	0	0	+	+	0
2	Cleaning	0	+	+	++	++
3	Water saving	0	+	-	++	+++
4	Load sustainability	0	+	+	0	++
5	Energy	0	+	-	-	--
6	Cost	0	+	0	-	--
7	Ease of assembly	0	+	0	-	-
8	Non Disconfiguration of product	0	+	+	-	-
9	Aesthetic	0	+	+	-	0
10	Robustness	0	+	-	-	-
11	Prototyping time	0	+	-	--	--
12	Space	0	+	0	-	--
	Sum of +	0	11	5	5	7
	Sum of -	0	0	4	9	11
	Sum of 0	12	1	3	1	2
	Net score	0	10	1	-4	-4
	Rank	4	1	2	3	3
	Continue	No	Yes	Revise	No	No

*Pugh's Concept Selection (Scoring) Matrix*  
 Table no.5.2

Selection criteria	W	R	W S	R	W S	R	W S	R	WS	R	W S
Life	10	3	30	5	50	5	50	4	40	4	40
Cleaning	8	3	24	4	32	5	40	5	40	4	32
Water saving	9	3	27	5	45	4	36	5	45	5	45
Load sustainability	10	3	30	5	45	5	45	4	40	5	50
Recyclable	8	3	24	5	40	5	36	5	40	3	24
Cost	8	3	24	5	40	4	32	4	32	2	16
Ease of assembly	9	3	27	5	45	5	41	5	45	2	18
Non disconfiguration of parts	7	3	21	4	28	4	28	4	28	2	14
Aesthetic	8	3	24	5	36	4	32	4	28	3	24
Robustness	8	3	24	4	32	3	24	3	20	2	16
Prototyping time	8	3	24	4	32	4	32	2	16	2	16
Space	9	3	24	5	41	3	27	3	23	2	18
Total score			303		466		423		397		313
Rank			5		1		2		3		4
Continue			No		Yes		Revis e		No		No
Continue			No		Yes		Revis e		No		No

**VI. RESULTS AND DISCUSSION**

In this chapter, the result obtained from laboratory tests help in finalizing the prototype model for the project. Various tests were conducted at IFB testing line and in BITS Chemistry laboratory, while BOD Test was conducted by ITA Labs Goa.

To check whether the rinse 3 drain water is filtered and reused in washing machine or not, for that we selected two filters

1. Polypropylene filter(PP)
2. Activated carbon filter(AC)

We conducted tests by using three possible combination of above mention filters for rinse 3 drain water

1. Polypropylene filter only
2. Activated carbon filter only
3. Polypropylene filter and Activated carbon filter only
4. Without filters



**Laboratory Validation**

- **Water turbidity:** This measures the clarity of the water—the higher the turbidity, the murkier the water.
- **Alkalinity:** This measures the ability of a solution to neutralize acids to the equivalence point of a carbonate—the lower the alkalinity, the less detergent present in the water solution.
- **Blender test foam height:** This measures the amount of foaming solution in a fluid—the lower the foam height, the less the detergent present in the water solution.
- **Total suspended solids:** These measures the amount of Suspended detergent (in grams/liter) left in the water after rinse 3.
- **Total dissolved solids:** this measures the amount of dissolved detergent (in grams/liter) left in the water after rinse 3.
- **Biological Oxygen Demand (BOD).**
- **Chemical Oxygen Demand (COD).**

**6.1 Alkalinity/pH Test**

This measures the ability of a solution to neutralize acids to the equivalence point of a carbonate—the lower the alkalinity, the less detergent present in the water solution. This test is conducted in IFB R&D by using pH meter in a below mention washing machine.

**Specification for the Ph Test:**

Table no.6.1.1

Dry weight(in Kg)	6.01
Wet weight (in Kg)	10.16
extractor wet weight(in Kg)	2.39
Sample Amount for nitration (in ml)	100
Spin rpm	800
Cycle Selected	Cotton 60
Time Duration	1hr. 55 min.
W/M Model Used	SENRITA Vx 6Kg
Load taken	6 Kg (Full load)
Washing Procedures	As per standard
No. of times load is rinsed for the test	5
Detergent used (in grams)	40

**Test results using IFB detergent**

Table no.6.1.2

	Test 1				
	Wash Water	Rinse 1	Rinse 2	Rinse 3	Extractor
Ph value	10.3	8.5	7.4	7	8.9
Amount of HCl. Used (in ml)	16.2	1.8	1	0.6	1
Wet weight				10.31	2.39
	Test 2				
	Wash Water	Rinse 1	Rinse 2	Rinse 3	Extractor
Ph value	10.2	9.4	7.8	7.6	8.9
Amount of HCl. Used (in ml)	9.1	4	1	0.7	0.9
Wet weight				10.17	2.37
	Test 3				
	Wash Water	Rinse 1	Rinse 2	Rinse 3	Extractor
Ph value	10.5	9.9	8.1	7.8	8.8
Amount of HCl. Used (in ml)	10.6	2.4	1	0.8	0.9-1.0
Wet weight				10.22	2.37

**Test results using normal TIDE detergent**

Table no.6.1.3

	Test 1				
	Wash Water	Rinse 1	Rinse 2	Rinse 3	Extractor
Ph value	10.5	9.2	8.3	7.8	9
Amount of HCl. Used (in ml)	7.9	1.4	0.8	0.7	1.5
Wet weight				10.04	2.41
	Test 2				
	Wash Water	Rinse 1	Rinse 2	Rinse 3	Extractor
Ph value	9.9		8.9	7.8	9
Amount of HCl. Used (in ml)	4.6		1.6	1.1	1.25
Wet weight				10.2	2.46

	Test 3				
	Wash Water	Rinse 1	Rinse 2	Rinse 3	Extractor
Ph value	10.4	8.5	7.85	7.7	8.9
Amount of HCl. Used (in ml)		1	0.8	0.6	0.7
Wet weight				10.23	2.52

6.2 Total suspended solids:

Table no.6.2.1 Specification for the TDS and TSS Test

S.No.	Requirement for the tests	
1	Filter Paper	Whatman Grade No. 1 Filter Paper, Whatman 1001-125
2	Desiccators	1 unit
3	oven	For evaporation(temperature maintained at 104 degree Celsius)
4	Silica gel	750 grams
5	Particle retention	11 micro metre
6	Flow rate	Medium
7	Porosity	Medium

Table no.6.2.2 Test result For Rinse 3 Drain Water Cycle before prototype:

Samples (50 ml each)							
S.No.		1	2	3	4	5	6
1	Wt. Of dry Petridis after drying (in grams)	53.3157	51.8579	44.8558	51.4062	51.3971	36.9237
2	Wt. of Petridis after filtration and followed by drying (in grams)	53.3255	51.8655	44.8639	51.4135	51.405	36.9303
3	TSS(grams)/50 ml	0.0098	0.0076	0.0081	0.0073	0.0079	0.0066
4	TSS(grams)/litre	0.196	0.152	0.162	0.146	0.158	0.132

6.3 Total Dissolved Solids Test results:

Table no.6.3.1 Test result For Rinse 3 Drain Water Cycle before prototype:

Samples (50 ml each)				
S. No.		1	2	3
1	Wt. of dry filter paper after drying	1.0408	1.0375	1.0294
2	Wt. of filter paper after filtration and followed by drying	1.0462	1.043	1.0325
3	TDS(grams)/50 ml	0.005	0.006	0.003
4	TDS(grams)/litre	0.108	0.11	0.062

Table no.6.3.2 Test results after prototype model using different combination of filters and detergents;

Test 1(IFB DETERGENT+7KgTEST LOAD+5 RINSES)				
	PP	AC	PP+AC	No Filters
Wt. Of dry petridish after drying (in grams)	44.8608	51.4116	51.8626	51.4026
Wt. of petridish after filtration and followed by drying (in grams)	44.8659	51.4205	51.8672	51.4137
TDS(grams)/50 ml	0.0051	0.0089	0.0046	0.0111
TDS(grams)/litre	0.102	0.178	0.092	0.222
TDS(mg)/litre	102	178	92	222
	PP	AC	PP+AC	No Filters
Wt. of dry filter paper after drying	1.0051	1.0435	1.0461	1.0534
Wt. of filter paper after filtration and followed by drying	1.009	1.049	1.048	1.0623
TSS(grams)/50 ml	0.0039	0.0055	0.0019	0.0089
TSS(grams)/litre	0.078	0.11	0.038	0.178
TDS(mg)/litre	78	110	38	178

Table no.6.3.3 Test results after prototype model using different combination of filters and detergents;

Test 2(IFB DETERGENT+7Kg TEST LOAD+W/O 5 RINSES)				
	PP	AC	PP+AC	No Filters
Wt. Of dry petridish after drying (in grams)	53.3207	44.8621	51.4127	51.864
Wt. of petridish after filtration and followed by drying (in grams)	53.3295	44.872	51.4205	51.877
TDS(grams)/50 ml	0.0088	0.0099	0.0078	0.013
TDS(grams)/litre	<b>0.176</b>	<b>0.198</b>	<b>0.156</b>	<b>0.26</b>
TDS(mg)/litre	176	198	156	260
	PP	AC	PP+AC	No Filters
Wt. of dry filter paper after drying	1.022	0.998	0.9865	1.038
Wt. of filter paper after filtration and followed by drying	1.0268	1.0058	0.9902	1.0485
TSS(grams)/50 ml	0.0048	0.0078	0.0037	0.0105
TSS(grams)/litre	<b>0.096</b>	<b>0.156</b>	<b>0.074</b>	<b>0.21</b>
TDS(mg)/litre	96	156	74	210

Test 3(IFB DETERGENT+7 KgNORMAL LOAD W/O 5 RINSES)				
	PP	AC	PP+AC	No Filters
Wt. Of dry petridish after drying (in grams)	51.4027	53.3209	51.864	51.4027
Wt. of petridish after filtration and followed by drying (in grams)	51.4126	53.3315	51.873	51.4178
TDS(grams)/50 ml	0.0099	0.0106	0.009	0.0151
TDS(grams)/litre	0.198	0.212	0.18	0.302
TDS(mg)/litre	198	212	180	302
	PP	AC	PP+AC	No Filters
Wt. of dry filter paper after drying	1.047	1.012	1.0345	1.0265
Wt. of filter paper after filtration and followed by drying	1.052	1.0178	1.0388	1.0338
TSS(grams)/50 ml	0.005	0.0058	0.0043	0.0073
TSS(grams)/litre	0.1	0.116	0.086	0.146
TDS(mg)/litre	100	116	86	146

**6.4 Biochemical oxygen demand:** Biochemical oxygen demand or B.O.D is the amount of dissolved oxygen needed by aerobic biological organisms in a body of water to break down organic material present in a given water sample at certain temperature over a specific time period.

The term also refers to a chemical procedure for determining DO amount. It is widely used as an indication of the organic quality of water. The BOD value is most commonly expressed in milligrams of oxygen consumed per liter of sample during 3-5 days of incubation at room temperature and is often used as a robust surrogate of the degree of organic pollution of water.

Testing condition



- 3 days at 27 degree Celsius.

Table no.6.4.1 BOD Sample Size

Sample	Volume
Rinse 3 water without PP filter	2 Liters
Rinse 3 water with PP filter	2 Liters

Table no.6.4.1 BOD Test Results

Sample type	Actual results mg/ltr	Acceptable range mg/ltr
Without PP filter	37.33	30
With PP filter	32	30

6.5 COMPILED RESULTS

Table no.6.5

Types of Filters	Size in Micron	Cost of Filter	Filter Life	Water Turbidity	Flow Rate	BOD
Polypropylene Filter	5	135	6 months (depending upon usage)	9 out of 10	1.46 lit/min	32mg/l
Activated carbon Filter	10	250	8 month approx.	7 out of 10	3 lit/min	-
PP+AC Filter	5&10	135+270	6 & 8 months	8 out of 10	0.625 lit/min	-
NO Filter	-	-	-	-	21.16 lit/min	37.33mg/l

Discussion:

- The results of rinse 3 water after filtration was very promising.
- On the bases of following criteria, it is decided to go for PP filter instead of A.C. filter or A.C. + PP filter.
  1. Amount of detergent left in Rinse3 water.
  2. pH Value of rinse3 water
  3. Cost of filter.
  4. Flow rate.
  5. Time required for draining.

6. POWER REQUIRED BY PUMPS.

Many more advantages are also associated with PP filters like vast working temperature range and effectiveness for all pH value ranges.

BOD Test were conducted by Italab(Goa) Pvt Ltd outside the IFB. As per the test results it is concluded that the rinse 3 water with PP filter values are very near to acceptable range, and the traces of aquatic microorganisms which led to skin diseases are not found. Hence this water can be reused in the machine for the further washing

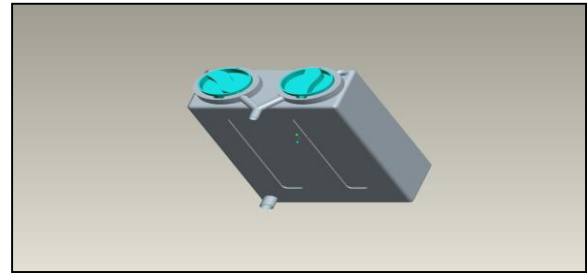

Fig.6.1 Final Prototype model in PRO-E:

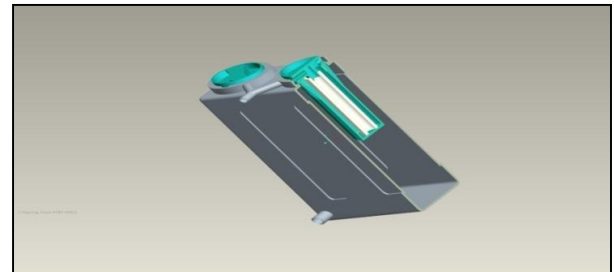

Fig.6.2 Final Prototype model in PRO-E cross sectional view:

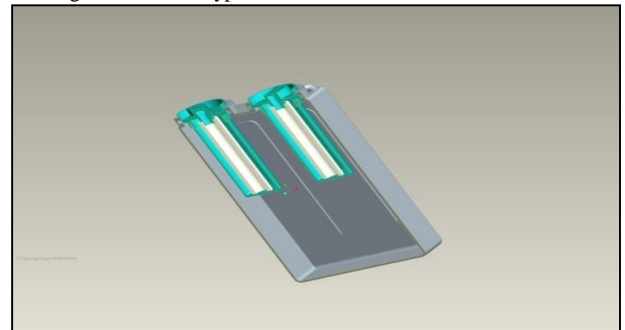

Fig.6.3 Final Prototype model in PRO-E cross sectional view:

VII. CONCLUSIONS

1. As per the test results we can infer that quality of rinse3 water using PP filter is comparable to the acceptable range of usable water.
2. BOD value of filtered rinse 3 water is 32 which is in close acceptance limits of normal water. Lower the BOD better is the water quality and higher is the amount of dissolved oxygen.
3. The amount of residual detergent in rinse3 water shrinks to half of the initial values.
4. The average pH Value of filtered rinse3 water is equal to 8 which are well within the best suited pH range for normal water.
5. The clarity of the filtered recirculated water is enhanced.
6. This reserved water can be reused in the machine for the rinse cycle.

## REFERENCES

- [1] Washing Machines.2006.  
<http://www.explainthatstuff.com/washingmachine.html>. Accessed January 15, 2008
- [2] Consumer Services Technical Education Group Presents: Front-Loading Automatic Washer. Copyright 2001 Whirlpool Corporation.
- [3] Diagrams and Parts List.  
[http://www.appliancepartspros.com/partsearch/model.aspx?model\\_id=265541](http://www.appliancepartspros.com/partsearch/model.aspx?model_id=265541).Accessed January 17, 2008.
- [4] Reducing Water Wastage in the UK. | 2008.  
<http://www.Waterwise.org.uk>. Accessed January 15, 2008.
- [5] High Performance Washer 2008.  
[http://www.empiredirect.co.uk/content/products/details/index~mode\\_lcode~AEG\\_L88810~dept~washing~subdept~WASHERS~brand~aeg.htm](http://www.empiredirect.co.uk/content/products/details/index~mode_lcode~AEG_L88810~dept~washing~subdept~WASHERS~brand~aeg.htm). Accessed January 16, 2008.
- [6] Haunch, Dennis W. 1996. Patent for Recirculation Pump System for a Washing Machine. Assigned to Whirlpool Corp. United States Patent No. 5,493,745.
- [7] Raney, et al. 2006. Patent for System and Method for Economically Viable and Environmentally Friendly Central Processing of home Laundry Assigned to Shell Corp. United States Patent No. 7,000,437.
- [8] Types of Cleanliness Measurement Methods. | 1999. Pacific Northwest Pollution Prevention Resource Center.  
<http://www.pprc.org/pubs/techreviews/measure/metypes.html>  
Accessed January 18, 2008.
- [9] Australian Federal Government. June 2005. Method for the Determination of Rinse Performance in Clothes Washers.  
<http://www.energyrating.gov.au/library/pubs/rinse-performance-final-2005.pdf>
- [10] Kaviany, Massoud Principles of Heat Transfer. Copyright 2001 WileyInterscience Publishing.
- [11] Munson, Bruce R. Fundamentals of Fluid Dynamics. Copyright 2005. Wiley Publishing.
- [12] Pony Pump Self-Priming — 360 GPH, 115 Volt, 3/8in., Model# 50AC110B. | 2008. Northern Tool & Equipment Online  
[http://www.northerntool.com/webapp/wcs/stores/servlet/product\\_6970\\_16818\\_16818](http://www.northerntool.com/webapp/wcs/stores/servlet/product_6970_16818_16818) Access April 14, 2008.
- [13] Pittsburgh, Penn. Leads the Country in Price of Water. | 2000. US Water News Online.  
<http://www.uswaternews.com/archives/arcsupply/tpitpen2.html>  
Accessed April 13, 2008.
- [14] Average Retail Price of Electricity to Ultimate Customers by End Use Sector ,by State. | 2007. Energy Information Administration.  
[http://www.eia.doe.gov/cneaf/electricity/epm/table5\\_6\\_b.html](http://www.eia.doe.gov/cneaf/electricity/epm/table5_6_b.html)  
Accessed April 13, 2008.