

# PV Array with Cascaded Multilevel Inverter and Medium Frequency Transformer for Grid Connection

Soumita Ghosh<sup>1</sup>, Arun Kumar M<sup>2</sup>, Dr. R. Prakash<sup>3</sup>, Anguraja R<sup>4</sup>  
Department of Electrical and Electronics Engineering,  
Don Bosco Institute of Technology,  
Bangalore, India.

**Abstract**— In the recent years, there has been an increased preference for the Photovoltaic power generation. As a result, the medium (>5 MW) and large (>10 MW) scale photovoltaic plants have garnered a lot of attention. The recent progress in power converters has resulted in grid integration of Renewable energy systems using Multilevel Inverter setup. This paper proposes a medium frequency transformer based multilevel inverter configuration to connect the PV system to a medium voltage grid. The proposed system will enhance the power quality, efficiency and also enable the medium voltage operation on the grid side.

**Keywords**—Photovoltaic; Multilevel inverter; Grid integration; SPWM

## I. INTRODUCTION

The Photovoltaic energy generation system is a source of continuous clean energy supply which will reduce the load on the conventional fossil fuels [1]. The system includes the solar array which includes the solar panels and supporting hardware. Considering the never ending supply of the sun's energy and minimum environmental emissions, the photovoltaic generation is a technology that can be used for mainstream electricity generation. Research and development in solid state semiconductors and new power converter configurations are being utilized to enhance the future medium or high voltage power converter systems. In this regard, the multilevel inverter configurations can be used for the possible medium voltage grid integration of photovoltaic energy generation systems.

The Multilevel Converters have successfully created a huge interest in the power sector in recent years owing to its high power applications [2]. The basic utility of these would be to synthesize the sinusoidal voltages from different levels of voltage. The power industry nowadays incorporates and involves a lot of higher power equipment, almost reaching the megawatt level. Considering several of the advantages of the multilevel inverter configuration the most significant ones would be the light weight of the overall setup and harmonic reduction in the output voltage waveforms without affecting the output power or switching frequency [3].

This paper discusses a medium-frequency transformer based multilevel inverter configuration which will connect the renewable energy generation system to the grid. The configuration used here is a cascaded multilevel inverter with boost converter, inverter and a medium frequency

transformer to be used for grid connection of the PV generation system. The use of multilevel inverters will enhance the power quality and efficiency and also enable the medium voltage operation on the grid side. Moreover it also induces the possibility of electrical isolation through the inverter which can be an important safety measure for connecting renewable energy system to the grid.

## II. ARCHITECTURE OF MULTILEVEL INVERTER BASED MEDIUM FREQUENCY GRID INTEGRATION

The proposed system architecture is shown in fig 1. The boost converter is connected at the output of the photovoltaic panel. It boosts the dc output of the PV panel. The inverter converts the dc input from boost converter to ac output which is then given to the medium frequency transformer [4]. The output from the medium frequency transformer is given to cascaded multilevel inverter which gives the stepped output having reduced harmonic content. Sinusoidal pulse width modulation (SPWM) technique is used for controlling output voltage if required.

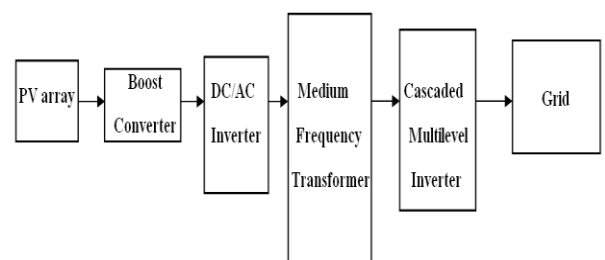

Fig 1: Block diagram of proposed system

### (A) PV Array

The photovoltaic array can be defined as linked assembly of the solar panels. It can be considered as a comprehensive power generating unit, which comprises of photovoltaic modules and panels. The power produced in one such module rarely satisfies the power demands of a home or office, thus these modules need to be linked together to form an array. These modules present in the photovoltaic array are generally connected in the series first in order to obtain the required voltage and then the individual strings undergo parallel connection to increase the current produced in the system.

In the proposed configuration Matlab Simulink is used to analyze the system. The table below shows the details.

PV Module Type	Kyocera KD205GX-LP
No. of cells per module	54
No. of series connected modules per string	6
No. of parallel strings	9
Open circuit voltage (Voc)	33.1999
Short circuit current (Isc)	8.35955
Voltage at maximum power point (Vmp)	26.6
Current at maximum power point (Imp)	7.70959

Table I: PV array data

The output of the photovoltaic array is in dc which is then given to the boost converter to step up the voltage level. The output waveform of the PV array is shown in fig 2.

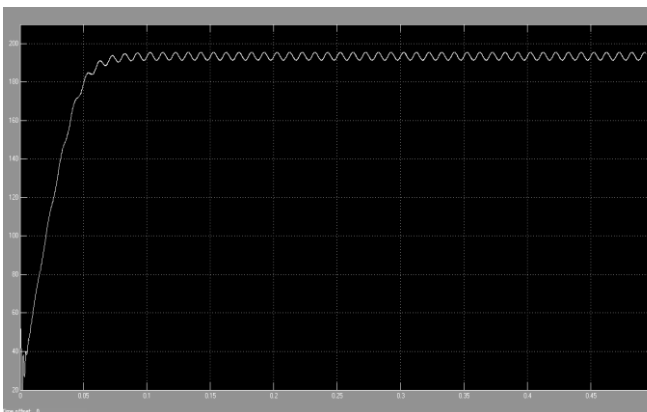

Fig 2. Output voltage waveform of PV Array

(B) DC to DC Boost Converter

The system uses a DC to DC boost converter connected to the PV panel output. This converter will boost the dc output voltage obtained from the photovoltaic panel.

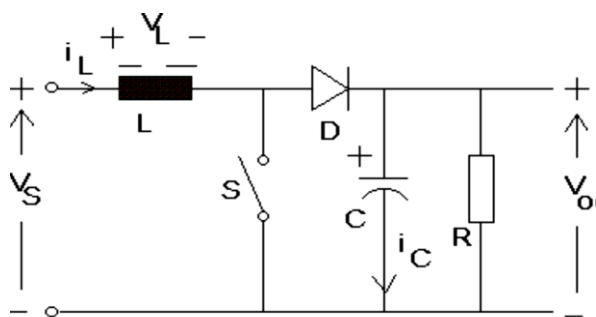

Fig 3. Boost Converter Circuit Diagram

The boost converter operation can be divided into mode 1 and mode 2 operations. During the mode 1 operation the switch is closed and the inductor gets charged through the battery and it stores the energy [5]. In this mode of operation, there is exponential increase in the inductor current assuming the charging and discharging of the inductor is linear. The diode will block the current flow and thus the load current which is supplied from the capacitor discharge remains constant. During the mode 2

operation the switch remains open thus making the diode short circuited. The previously stored energy in the inductor slowly discharges through opposite polarities and the capacitor gets charged. The load current in this operation remains constant.

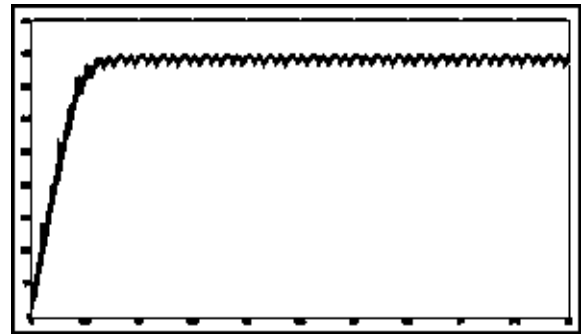

Fig 4. Output voltage waveform of Boost Converter

Calculation of Circuit Parameters:

Inductance (L):  $D(1-D)^2 \cdot R / (2 \cdot f)$

Capacitance (C):  $D \cdot V_{out} / (V_r \cdot R \cdot f)$

Where D = duty cycle

R = resistance

F = 1/T = switching frequency

V<sub>r</sub> = ripple voltage

Boost Converter Parameter	Value
Inductance (L)	96 uH
Capacitance (C)	27 uF
Switching Frequency (fs)	50 KHz
Gate Voltage (VG)	15 V
Duty Ratio (D)	50
Load Resistance (R)	100 ohm
Output Voltage (Vo)	400 V

Table II: Boost Converter data

The boost converter also stabilizes the output voltage of the photovoltaic panel by smoothening small disturbances. Thus the result is a steady higher voltage level. Fig 4 shows the output voltage waveform of the boost converter.

(C) Single phase inverter

An inverter is an electronic device that converts the DC to AC output. A typical inverter uses a relatively stable dc power supply and converting it to a type of AC output. Inverters are using different types of dc sources such as fuel cells, batteries or solar panels [6].

Full bridge inverter consists of four power switches and a diode across power switches. When S1 and S2 conducts, load voltage is +V<sub>s</sub> and when S3 and S4 conducts load voltage is -V<sub>s</sub>. Frequency of the output voltage can be controlled by varying the time period. The power switches S1, S4 or S2, S3 are connected in H-Bridge fashion where the source is connected between the series connection of S1, S4 and S2, S3. During inverter operation, it should be ensured that two power switches in the same branch of the H-Bridge do not conduct simultaneously as it would lead to a direct short circuit of the source. The inverter connects the boost converter at the output of the

PV panel to the medium frequency transformer as shown in fig 1.

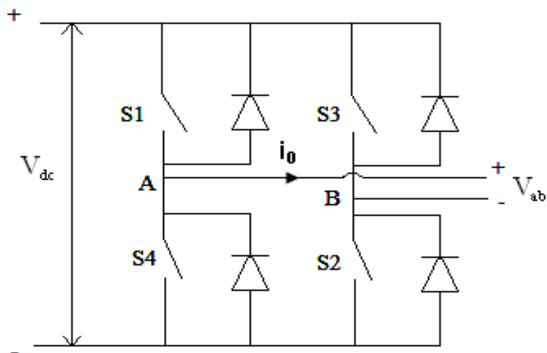

Fig 5. A Single phase full-bridge inverter

Frequency	500 Hz
Period (secs)	1/500
Output Waveform	Square wave
Output Voltage	380 v
Pulse Width (% of period)	50

Table III: Single phase inverter data

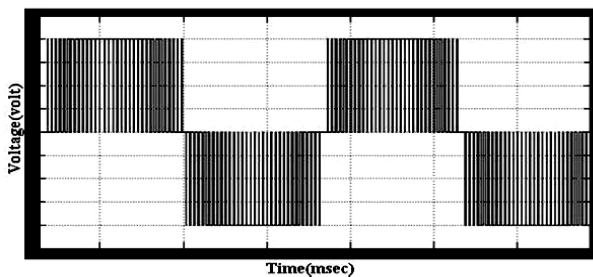

Fig 6. Output voltage of single phase h bridge inverter

The inverter connects the boost converter at the output of the PV panel to the medium frequency transformer. The inverter gives ac output which is given input to the medium frequency transformer.

*(D) Medium Frequency Transformer*

Power generating utilities generally use huge transformers of low frequency to transfer electrical energy. These transformers are not only huge in size and heavy but also incur losses which affect the overall efficiency of the system. The larger area of the windings and the core result in increased losses in the core and copper losses. So a few such transformers connected in a utility can well affect the overall system efficiency. A method to avoid using these large transformers is to employ a Medium frequency link isolation transformer. These are much smaller in size, lighter in weight and have an overall compact design. Also it provides minimized voltage stress and better current sharing among the power devices. These medium frequency transformers are also inherently multi-system operable. In the proposed configuration this transformer connects the PV – boost converter system to the cascaded multilevel inverter system. The transformer data is given in Table IV. The medium frequency transformer link connects

the output of the H-bridge inverter to the cascaded multilevel inverter. The output waveform of the transformer is shown in fig 7.

Table IV. Medium frequency transformer data

SI No.	Parameter	Value
1	Winding ratio	1:2
2	Voltage step up	1:2
3	Power rating	2.5KVA
4	Frequency	500 Hz
5	Output voltage	800 V

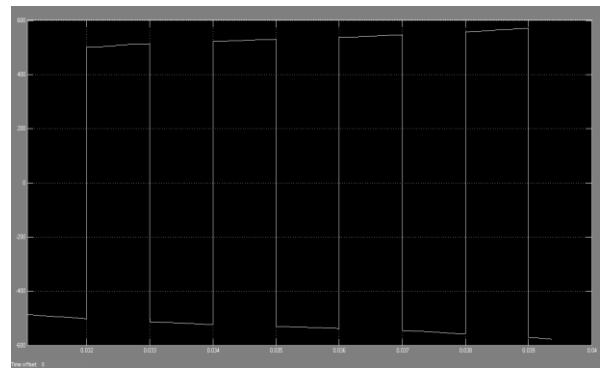

Fig 7. Output voltage waveform of medium frequency transformer

*(E) Cascaded H-Bridge Multilevel Inverter*

There are different configurations of multilevel inverter systems [8]. In the proposed system, modules consisting of bridge rectifier and cascaded H-bridge multilevel inverter system is connected at the output of the medium frequency transformer as shown in fig 1 with separate dc sources to obtain the stepped AC voltage. For example cascading of two H-bridges result in stepped output voltage with five levels. The bridge rectifier rectifies the AC output voltage of the medium voltage transformer and provides DC input voltage to the cascaded H-bridge multilevel inverter (CHBMLI).

The fig 8 shows the circuit of a cascaded H-bridge inverter that is implemented in this paper. It consists of two H-Bridge inverters connected in cascade with the power switches. The input DC voltage is usually a fixed voltage whereas the output ac voltage can be varied accordingly. Using different combinations of these switches from S1 to S4, the inverter level generates different voltage levels at the output. In order to synthesize the multilevel output waveform, the ac output of each of the H-bridge cells at different levels is connected in series. The number of output voltage levels in the cascaded multilevel inverter is defined as  $N = 2s + 1$  where s is the number of dc sources.

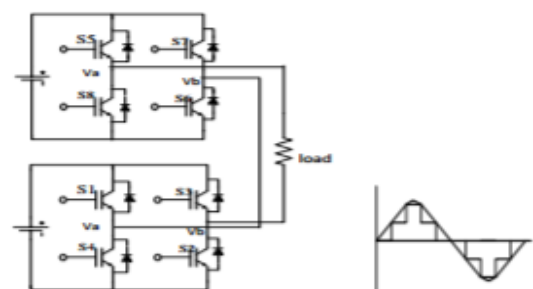

Fig 8. Proposed cascaded multilevel inverter configuration

The operation of the CHBMLI is shown in table V. The table clearly gives the output voltage obtained when different switches are turned on.

Table V. Switching operation sequence of different voltage levels obtained

Sl.NO	VOLTAGE LEVEL	OPERATING SWITCHES
1	0	S1 S3 S5 S7
2	$V_{dc}$	S2 S6 S8 S2
3	$2V_{dc}$	S1 S6 S5 S2
4	$-2V_{dc}$	S3 S8 S7 S4
5	$-V_{dc}$	S3 S7 S5 S4

The multilevel inverter obtains the stepped output voltage levels from several dc sources which follows the sinusoidal waveform. The significance of using multilevel inverter is increased output with better electromagnetic compatibility. It has modularized layout and problems regarding dc link voltage unbalancing is reduced. The fig 9 shows the output waveform for the simulated cascaded multilevel inverter configuration.

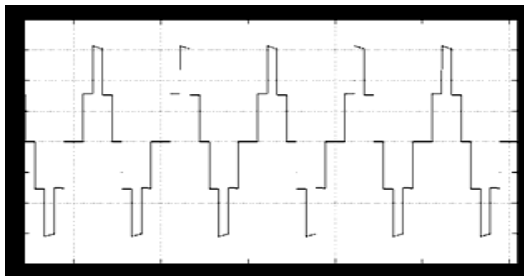

Fig 9. Output voltage waveform for a five level cascaded multilevel inverter

Fig 10 shows the overall simulation model of the proposed system of a medium frequency transformer based multilevel inverter system [9].

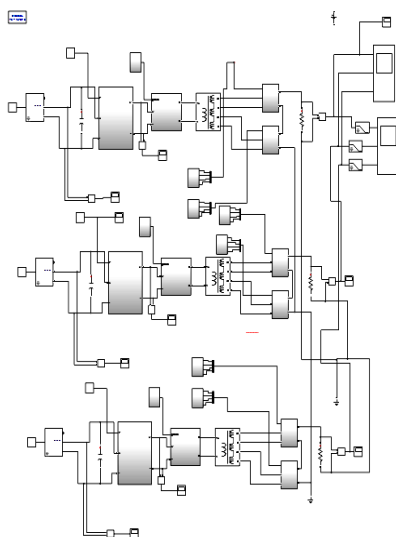

Fig 10. Proposed system configuration of a Medium frequency transformer based multilevel converter system.

### III. PULSE WIDTH MODULATION

Pulse width modulation is the procedure of modifying width of the pulses in a pulse train in direct proportion to a small control signal. The greater the control voltage, the wider the resulting pulses will become. By using a sinusoid of the required frequency as the control voltage for a PWM circuit, it is possible to produce a high-power waveform whose average voltage varies sinusoidally so that controlled output voltage can be obtained. This is implemented in the PWM driver circuit.

A comparator is a device that compares the input voltage to a reference signal (sine wave generator) and turns transistors on or off depending on the results of the test. This is shown in fig 11. The reference wave is the sine wave.

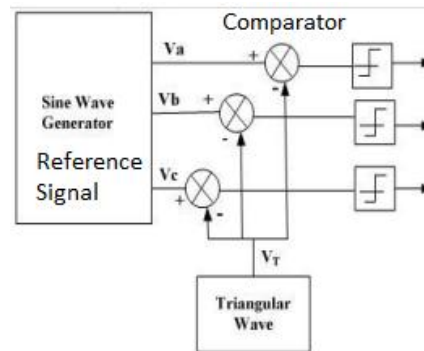

Fig 11. SPWM Signal Generator

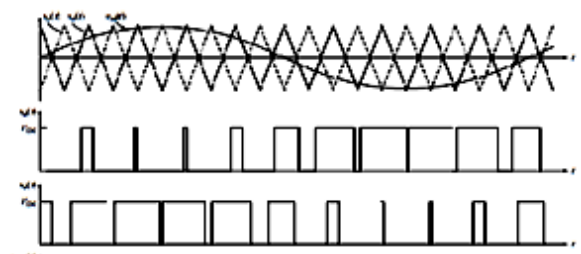

Fig 12. PWM waveforms

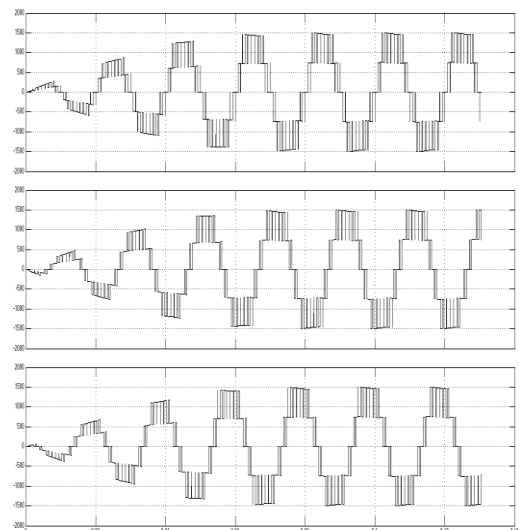

Fig 13. Output of the Cascaded Multilevel inverter for proposed three phase system

This waveform when compared with high frequency carrier triangular waveform, the pulses are generated [11]. That is given as input to the multilevel inverter. This method filters an output voltage waveform by varying width to produce a sinusoidal waveform. The pulse width is changed by changing the frequency and amplitude of reference voltage. Consider the fig 11 of a SPWM signal generator where modulating waveform is compared with a triangular waveform of high frequency. In a three phase voltage source multilevel inverter, the SPWM is achieved when the sinusoidal voltages  $V_a, V_b, V_c$  given in fig 11 which are  $120^\circ$  out of phase with each other. Figure 12 shows the pulses generated by the driver circuit which are given to the power switches of the H-Bridge circuit as shown in fig 5. The output waveform of the proposed system in fig 10 is shown in fig 13.

#### IV. RESULTS AND DISCUSSIONS

A medium frequency transformer based cascaded multilevel inverter system with a boost converter was used in order to connect the photovoltaic system to the power grid.

##### 1. Reduction in Total Harmonic Distortion (THD):

The fig 14 shows the overall THD of the systems as 26.33% at the output of the cascaded multilevel inverter configuration. SPWM is applied to the system which results in a significant decrease in the total harmonic distortion. The fig 15 shows the FFT analysis of the output voltage waveform after harmonic reduction which shows the THD to be 3.83%. This output with reduced harmonics is synchronized and given over to a medium voltage grid.

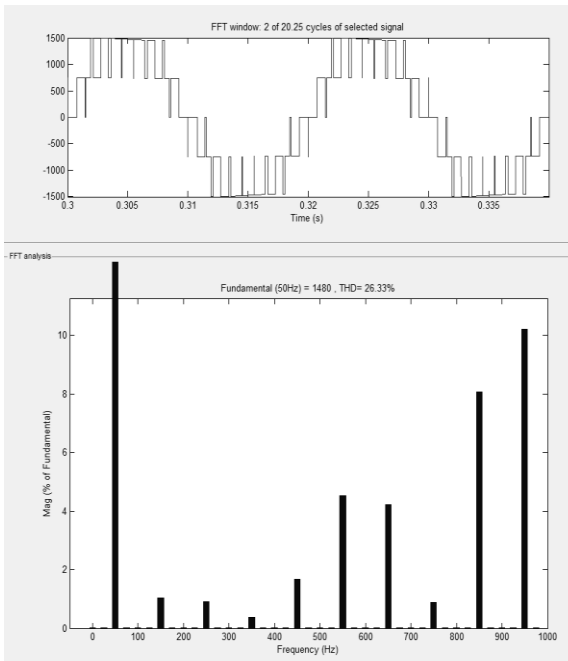

Fig 14. Spectrum of voltage waveform

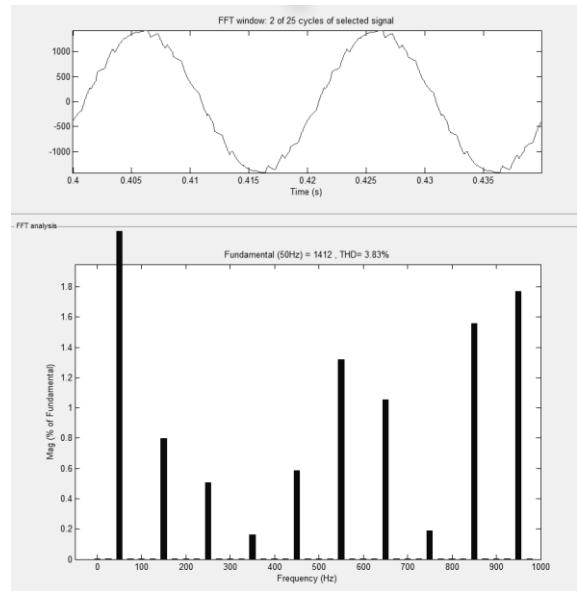

Fig 15. Spectrum of output with reduced THD

2. Replacing the 50Hz power transformer with a medium frequency transformer leads to reduction in the size and weight.
3. Reduced losses incurred in medium frequency transformer which leads to increased efficiency
4. Voltage stabilization and step-up at the input side using the DC/DC boost converter.
5. Increased power output using Multilevel Inverter.

#### V. CONCLUSION

In this paper a medium voltage frequency transformer based cascaded multilevel inverter system with boost converter for photovoltaic connection to the grid is proposed. The proposed system is simulated using MATLAB/SIMULINK and the results are discussed. The proposed system can be utilized for medium voltage, medium frequency connection of renewable energy generation systems. The proposed configuration aims to provide a light, compact and efficient system with minimum losses taking place for the energy generation systems. The system provides better quality of output power with harmonic reduction for the power grid. Thus in the proposed system the total harmonic reduction (THD) value has been reduced up to around 3.83 % which increases the efficiency of the system.



## REFERENCES

- [1] Fernao Pires, J.F Martins, D.Foito, Chen Hao, "A Grid Connected Photovoltaic System with a Multilevel Inverter and a Le – Blanc Transformer", IJRER, Vol.2, No. 1, 2012
- [2] Md. Rabiul Islam, Youguang Guo, Jianguo Zhu, "A High-Frequency Link Multilevel Cascaded Medium-Voltage Converter for Direct Grid Integration of Renewable Energy Systems", IEEE, Vol. 29, No. 8, Aug 2014.
- [3] Jian Chen, Xianglian Xu, Shunji Li, Ka Hu, "Implementation of Grid Connected Cascaded Multilevel Inverter Based on FPGA for Centralized Photovoltaic Generation", Energy Procedia, Volume 17, Part B, 2012.
- [4] Bibek Mishra, Bibhu Prasanna Kar, "Matlab Based Modelling of Photovoltaic Array Characteristics" , Dept. of EE, NIT Rourkela, May 2012
- [5] J.Lu and D.Butler, "High Frequency Transformers for DC/DC Converter used in Solar PV System." Jan 2010, Volume 4, Journal of Energy and Power Engineering.
- [6] A.A Mamun, M.F. Elahi, M. Quamruzzaman, M.U.Tomal, "Design and Implementation of Single Phase Inverter", IJSR, Vol. 2, Issue 2, Feb 2013.
- [7] Chong H.Ng, Max A.Parker, Peter J.Tavner, Ed Spooner, "A Multilevel Modular Converter for a Large, Lightweight Wind Turbine Generator", IEEE, Vol. 23, No. 3, May 2008.
- [8] Fujin Den, Zhe Chen, "A New Structure based on Cascaded Multilevel Converter for Variable Speed Wind Turbine", Inst. Of Energy Technology, Aalborg University, Denmark, IEEE 2010.
- [9] Bailu Xiao, Lijun Hang, Jun Mei, Cameron Riley, "Modular Cascaded H-Bridge Multilevel PV Inverter with distributed MPPT for Grid-connected applications", IEEE, Vol.51, No. 2, March 2015.
- [10] P. Jyothi Bhaskara Rao and B. Srikanth "Harmonic Reduction in Grid Connected Solar PV System by using SVPWM Technique". International Journal of Applied Engineering Research ISSN 0973-4562 Volume 11, Number 6 (2016).
- [11] G. Uma Devi, P. Manikandan, A. Thimi Theu, S. Prabakaran, "Implementation of Multilevel Inverter using Sinusoidal Pulse Width Modulation Technique", IJSETR, Volume 2, Issue 7, July 2013.
- [12] Mahajan Sagar Bhaskar Ranjana, Pandav Kiran Maroti, Ruchita Maheshwari, Pachagade Ruchi M, "Multilevel Inverter with Level Shifting SPWM Technique using fewer number of switches for Solar applications", IJRET, Vol.4, Issue 10, Oct 2015

## AUTHORS

Soumita Ghosh – B.E graduate in Electrical and Electronics Engineering (EEE) from Siddaganga Institute of Technology, Tumkur in 2014. Currently pursuing M.Tech degree in Power System Engineering (PSE) from Don Bosco Institute of Technology (DBIT) Bangalore. Her research interests include renewable energy generation, power systems and transmission and distribution



Arun Kumar M – He has graduated his BE in 2000 and M.E in 2004 from University Visveswaraya College of Engineering, in Bangalore respectively. He is presently working in Don Bosco Institute of Technology (DBIT), Bangalore as Associate Professor and Ph.D from Visveswaraya Technological University, Belgaum. His research areas include Power Electronics, FACTs, Smart Grids and Electric Vehicles.



Dr. R. Prakash – Received B.E in Electrical and Electronics Engineering (EEE) from Basaveshwara College Engineering, Bagalkot. Completed M.E in Power System Engineering from Walchand College of Engineering, Sangli and Ph.D. in Power System Engineering from VTU, Belgaum. He is presently working as Head of the Department in Don Bosco Institute of Technology. His research interests include power system, renewable energy, microgrids.



Anguraja R –Received B.E in Electrical and Electronics Engineering from Bharathidasan University, and M.Tech in High Voltage Engineering from SASTRA University. Currently pursuing Ph.D in High Voltage Engineering from Jain University.



He is currently Associate Professor in Don Bosco Institute of Technology. His interests include High Voltage Engineering, renewable energy and power system.