

Performance improvement of 7 bus system using TCSC

Shrirang Kulkarni

Electrical and Electronics Engg
BLDEA's Dr.P G Halakatti CET
Bijapur, Karnataka, India

Abstract— TCSC increases the performance of system by decreasing reactance of line and hence increases the power flow in the line as well as reduces the line losses. Optimal location for placing of TCSC is found by performance indices calculation to reduce overloading of each transmission line in normal case and contingency cases. 7 bus system is used to carry out simulation through MATLAB SIMULINK.

Keywords— FACTS, TCSC

I. INTRODUCTION

In present days, Power demand is increasing every year, to meet this demand the expansion of power generation and transmission is necessary. But at the same time it is limited due to limited resources and environmental restrictions. , installation of new transmission lines with the large interconnected power system are limited to some of the factors like economic cost, environment related issues. As a consequence some transmission lines are heavily loaded. The proposed concept is power electronics based technology has been mainly used for solving various power system control problems.

Continuous and fast improvement of power electronics technology has made FACTS (Flexible AC Transmission system) a promising concept for power system development in the coming decade. Among a variety of FACTS devices, Thyristor controlled series compensator (TCSC) is chosen and well designed to enhance the transient stability of the power system.

TCSC increases the performance of system decreasing reactance of line and hence increases the power flow in the line but cost of FACTS device is high. An approach to determine the most suitable location for placing the TCSC in order to enhance the

Power flow in transmission line using contingencies analysis and ranking. So it is required to find optima location of FACTS device. Performance indices are defined and ranked to place TCSC in line which informs to locate TCSC in better position.

Paper deals with the modeling and simulation of TCSC for three machine seven bus system. Simulink models are developed for case study systems with and without TCSC.. The complete digital simulations are performed in the MATLAB/SIMULINK environment to provide comprehensive understanding of the issue. Section 2 gives information about TCSC model .section 3 introduces the performance indices and ranking process. Result and discussions are carried out in section 4.

II. TCSC MODEL

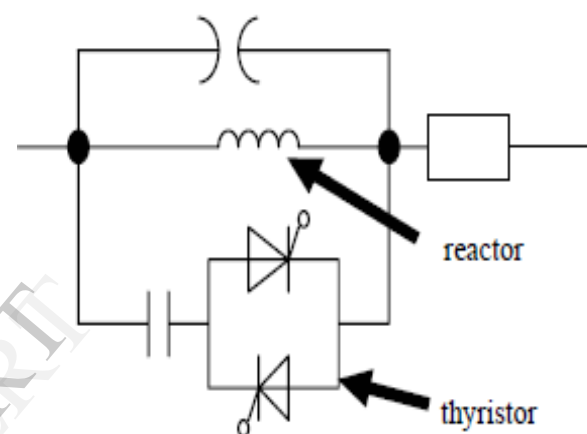

Fig.1 TCSC(Thyristor controlled series compensator) model

Figure 1 of TCSC consists of three main components: Capacitor bank, bypass inductor and bidirectional thyristors SCR1 and SCR2. Characteristics of TCSC placed in a transmission network provides the power flow control in a power system improving the damping power oscillation and reduces the net loss providing voltage support. It can be represented as variable reactance.

The thyristors in TCSC device offers a flexible adjustment with the ability to control the continuous line compensation. TCSC controllers effectively used for solving power system problems of transient stability, dynamic stability, steady state stability and voltage stability in long transmission lines. Transmission lines are represented as pi-equivalent parameters in simulation

In this paper it is designed based on the thyristor based FACTS technology that has the ability to control the line impedance with a thyristor-controlled capacitor placed in series with the transmission line. It is used to increase the transmission line capability by installing a series capacitor that reduces the net series impedance thus allowing additional power to be transferred. The effect of TCSC on the network can be seen as controllable reactance in line that compensates the reactance of line.

III. PERFORMANCE INDICES CALCULATION

The optimal locations to install the FACTS devices for secured Power flow under normal and contingency condition are presented in this section. The overload on the transmission line is eliminated by placing TCSC in the appropriate location.

Active power performance index (Pip) is introduced in this section for installing TCSC at suitable location to achieve secured power flow under normal operating condition. The essential idea of TCSC placement in the proposed methodology is to determine a line, which is most suitable for eliminating the overloads on the transmission lines

a) Active power performance index (Pip)

$$Pip = [(Pi/P_{max})^{2n}] \tag{1}$$

Where Pi=Active power flow in line i.

P_{max}=Maximum power flow in line i

n=specified exponent(Here value of n is kept unity)

L=total number of transmission lines in the system

. Maximum power transfer can be expressed by formula

$$P_{max} = Vi * Vj / X \tag{2}$$

Where Vi=Voltage at bus i obtained from power flow

Vj=Voltage at bus j obtained from power flow

X=Reactance of line connecting bus i and bus j

Pip value is calculated for all the lines .the line with least positive value is considered and ranked first. next least valued is second and so.TCSC is placed on line having rank 1 .

b) Contingency capacity Performance index (CPI)

Contingency capacity Performance index (CPI) is introduced in this section for installing TCSC at suitable location to achieve secured power flow under contingency condition.

Contingency capacity performance index is calculated as follows

$$CPI = [(P_{max} - Pi) / P_{max}] \tag{3}$$

Where P_{max} =Maximum power flow in line i

Pi=Active power flow in line i

CPI value is calculated for all the lines .the line with highest positive value is considered and ranked first. next highest valued is second and so.TCSC is placed on line having rank 1 .

IV. RESULTS AND DISCUSSIONS

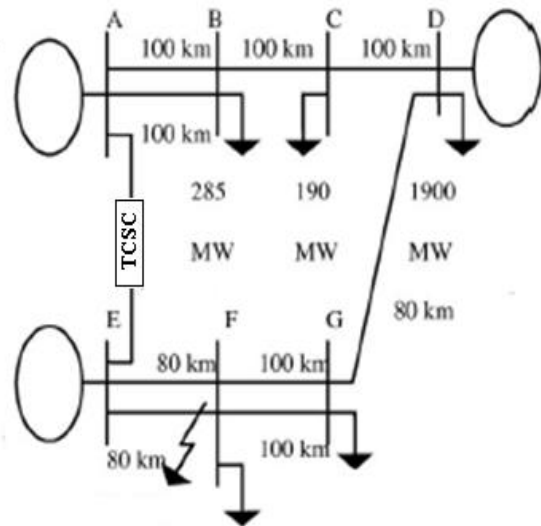

Fig 2.Three machine 7 bus system test system

Figure 2 is the three machine 7 bs system test system considered for case study.Consists of 3 machines ,7 buses, 5 loads and 10 transmission lines.Test system is simulated in Matlab simulink for 5 seconds.

TABLE 1

.Line data without TCSC under normal condition

Line no	Power		Loss		%loading
	MW	Mvar	MW	Mvar	
L1 (A-B)	385	79	5	-5	96.12
L2 (B-C)	484	138	8	38	126
L3 (C-D)	381	79	5	2	95
L4 (D-G)	355	-25	1	21	88.75
L5 (G-F)	234	46	3	7	58.5
L6 (G-F)	234	46	3	7	58.5
L7 (F-E)	279	54	12	1	70
L8 (F-E)	279	54	12	1	70
L9 (E-A)	159	98	4	3	39.7
L10 (A-B)	385	79	5	-5	96.12

From table 1 it is observed that transmission line number 2(L2) is overloaded at 126%.The main objective of TCSC is for power flow control such that overloading of the line is brought to approximately 125% or so.Suitable location for TCSC is identified based on values of performance indices calculated.

TABLE 2
Ranking based on Active power performance index

Line no	Pip	Ranking
L1	0.9264	9
L2	1.46	10
L3	0.9072	7
L4	0.7876	6
L5	0.342	2
L6	0.342	3
L7	0.4865	4
L8	0.4865	5
L9	0.15	1
L10	0.9264	8

TABLE 3
Test system data with TCSC under normal condition

Line no	Power		Loss		%loading
	MW	Mvar	MW	Mvar	
L1	299	21	3	4	74.75
L2	327	51	3	3	81.75
L3	228	47.4	2	10	57
L4	205	59	2	7.2	51.25
L5	332	71.4	7	8	83
L6	332	71.4	7	8	83
L7	386.4	96.2	4	4	96.5
L8	386.4	96.2	4	4	96.5
L9	380	78.5	5	10	95
L10	299	21	3	4	74.75

Line 9(L9) is having Pip value 0.15 so ranked first.From Table 3 provides optimal solution for optimal placement of TCSC in line L9 (rank 1) decreases the overloading to 81.75 %.which is exempted upto120%.Other line are also having %overloading within limit.

TABLE 4
Line data without TCSC under contingency condition

Line no	Power		Loss		%loading
	MW	Mvar	MW	Mvar	
L1	674	190	16	97	168.5
L2	397.4	93.61	6	22	99.35
L3	300	75	3	1.8	75
L4	379.47	-9	1	-5.38	94.75
L5	248.9	50.5	3	4	62.2
L6	248.9	50.5	3	4	62.
L7	295.7	57.5	3	1.1	73.9
L8	295.7	57.5	3	1.1	73.9
L9	190	103.8	5	97	47.5

Contingency created by taking out the Line L10. From table 4 it is observed that transmission line number 1(L1) is overloaded at 168%.under contingency condition.

TABLE 5
Ranking based on contingency performance index

Line no	CPI	Ranking
L1	-0.685	
L2	0.0065	8
L3	0.250	6
L4	0.051	7
L5	0.3775	2
L6	0.3775	3
L7	0.260	4
L8	0.260	5
L9	0.525	1

Line 9(L9) is having CPI value 0.525 which is the highest positive value so ranked first TCSC placed in that line to reduce overload.

TABLE 6.

Line data with TCSC under contingency condition

Line no	Power		Loss		%loading
	MW	Mvar	MW	Mvar	
L1	497.2	59.8	8	69	124.3
L2	234.2	20.1	1.5	16	58.6
L3	139	36	0.72	25	34.75
L4	280	8.7	3	5	70
L5	370.7	77	6	13	92.67
L6	370.7	77	6	13	92.67
L7	425	106.1	6	17	106.25
L8	425	106.1	6	17	106.25
L9	496.9	-150	3	7	124

From the above Table 6 it is observed that with optimal location of TCSC in line L9 decreases the overloading to 124 %.which is exempted upto125%.Other line are also having %overloading within limit.

V. CONCLUSION

As per the objective study of paper, the simulation result shows that the effective placement of FACTS device TCSC in optimal location of the transmission line based on performance indices decreases the overloading of line under Normal operating condition and contingency condition. The TCSC changes the real and reactive power of the system in any location, but the optimal location presents the best benefit on power losses. TCSC's effectiveness for loss minimization is verified and tabulated.

VI. REFERENCES

1. Narain G.Hingorani and Laszlo Gyugyi, "Understanding FACTS: concepts and technology of flexible AC transmission systems", 2000 Edition.
2. K.R.Padiyar, "FACTS Controllers in Power Transmission and Distribution", 2013 Edition.

3. K shanmukhsundar; H.M.ravikumar "Selection of TCSC location for secured optimal power flow under normal and network contingencies", Science direct (Elsevier), Electric Power Research 34(2012) 29–37.
4. X.Y. Li "Nonlinear controller design of thyristor controlled series compensation for damping inter-area power oscillation", Science direct (Elsevier), Electric Power Research 76 (2006) 1040–1046.