

Performance Analysis of Multiuser DS-CDMA System

Tata Balaji¹, J.Ravindrababu²

E.C.E. Dept. Prasad V. Potluri Siddhartha Institute of Technology, Vijayawada

Abstract - This paper examines the Bit Error Rate (BER) performance of Multi-user Direct Sequence Code Division Multiple Access (DS-CDMA) using spreading codes in fading channels. Code Division Multiple Access (CDMA) system operating over frequency selective, slowly fading channels is considered and its performance is studied analytically and by computer simulations. We consider the downlink of a cellular radio system where for each user a BPSK modulation is used. The spreading codes are arranged in a way that reduces the effect of the multipath fading channel and restores some of the orthogonality losses between users. The obtained results show considerable performance improvement compared to conventional OFDM and to CDMA that uses single spreading codes. Moreover, the spreading codes chosen by the method are in a consistent sequence. Using this code selection method, the system capacity of MU-CDMA can be effectively increased without increasing too much system complexity. Simulation results show that the presented method can work well for fading channels.

Keywords BPSK, DS/MC-CDMA, Walsh codes, Gold codes, PN Sequence

I. INTRODUCTION

Code Division Multiple Access (CDMA) is a modulation scheme that combines the advantages of Orthogonal Frequency Division Multiple (OFDM) and Code Division Multiple Access (CDMA) to provide robustness against frequency selectivity in wireless channels. In MC-CDMA, the total system bandwidth is divided into a number of sub-bands, where each sub-band may use direct-sequence (DS) spreading and each sub-band signal is transmitted using a subcarrier frequency. CDMA systems using the OFDM technique resolve the frequency selectivity in multipath fading channels and have good spectral properties. The addition of a spread spectrum component to the OFDM introduces a frequency diversity gain that can combat deep multipath fading situations[1].

Future wireless communication systems must be able to accommodate a large number of users and simultaneously to provide the high data rates at the required quality of service. MC-CDMA is taking the advantage of two advanced technological concepts of wireless communications such as orthogonal frequency division multiplex (OFDM) and the code division multiple access (CDMA), what results especially in high spectral efficiency, the multiple access capability, robustness in the case of frequency selective channels, simple one-tap equalization, narrow-band interference rejection and high flexibility of the MC-CDMA[1].

OFDM is currently being used in several new radio broadcast systems including the proposal for high definition digital television (HDTV) and digital audio broadcasting (DAB). However, little research has been done into the use

of OFDM as a transmission method for mobile telecommunications systems. In CDMA, all users transmit in the same broad frequency band using specialized codes as a basis of channelization. Both the base station and the mobile station know these codes, which are used to modulate the data sent.

One of the major requirements posed to the CDMA is to reach the required data rate at the acceptable bit error rate (BER) and acceptable complexity for the defined number of the active users. The aim of our study is to find by means of computer simulations the pair of a receiver and a set of the spreading codes able to provide the best BER performance under the mentioned conditions. The simulation results show that the maximum improvement of the CDMA performance compared to other system configurations is achieved if pseudorandom codes are used as the spreading sequence. It will be also shown that this result is true especially for the scenario with strongly nonlinearly distorted CDMA signals[1].

II. MULTIPATH FADING CHANNELS

The communication channel is the medium which the transmitting radio signal goes through in order to reach the receiver. The channel can be modeled as a linear filter with a time varying channel impulse response. A channel impulse response describes the amplitude and phase effects that the channel will impose on the transmitting radio signal, as it transmits through the medium. IS-95 CDMA Communication channels are often modeled as a multi path fading channel, as it is the best Modeling for a mobile communication channel.

The term "fading" describes the small-scale variation of a mobile radio signal. As each transmitting signal is represented by a number of multi path and each having different propagation delays, the channel impulse response is different for each multi path. Therefore, not only the channel response is time varying, the channel response is also functional dependent on the propagation delay[3].

III. SPREADING CODES

The main principle of Spread Spectrum communication is that the bandwidth occupancy is much higher than usual. Because of this much larger bandwidth the power spectral density is lower, in the channel the signal just looks like noise. The Spreading is done by combining the data signal with a code (code division multiple access) which is independent of the transmitted data message[2][3].

A) Gold Codes :

A Gold code, also known as Gold sequence, is a type of binary sequence, used in telecommunication (CDMA) and satellite navigation (GPS). Gold codes are named after Robert Gold. Gold codes have bounded small cross-correlations within a set, which is useful when multiple devices are broadcasting in the same range. A set of Gold code sequences consists of $2^n - 1$ sequences each one with a period of $2^n - 1$.

A set of Gold codes can be generated with the following steps. Pick two maximum length sequences of the same length $2^n - 1$ such that their absolute cross-correlation is less than or equal to $2^{(n+2)/2}$, where n is the size of the LFSR used to generate the maximum length sequence (Gold '67). The set of the $2^n - 1$ exclusive-ors of the two sequences in their various phases (i.e. translated into all relative positions) is a set of Gold codes. The highest absolute cross-correlation in this set of codes is $2^{(n+2)/2} + 1$ for even n and $2^{(n+1)/2} + 1$ for odd n .

The exclusive or of two Gold codes from the same set is another Gold code in some phase. Within a set of Gold codes about half of the codes are balanced — the number of ones and zeros differs by only one. The figure 1 shows the Gold Sequence generator where an XOR operation will be done between two m-sequences [2][3].

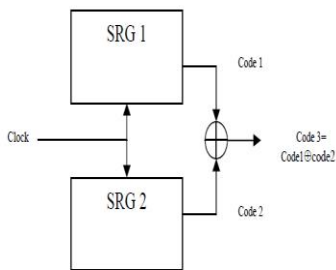

Fig 1: Gold Code Sequence Generator

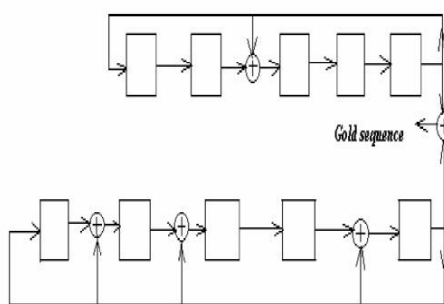

Fig 2: Generation of Gold Code Sequence of length 31

B) Walsh Codes
Walsh coding is performed after data scrambling in the transmitter. Each data symbol coming Out of the scrambler is replaced by 64 Walsh chip sequence. Each 64 Walsh chip sequence corresponds to a row of the 64 by 64 Walsh matrix (also called A Handmaid matrix).The Walsh matrix contain one row of all zeros, and the remaining Rows each have an equal number of ones and zeros. Walsh codes are defined as a set of N codes, denoted W_j , for $j = 0, 1, \dots, N - 1$, which have the following properties:

- W_j takes on the values +1 and -1.
- $W_j[0] = 1$ for all j .
- W_j has exactly j zero crossings, for $j = 0, 1, \dots, N - 1$.
- $W_j W_k^T = \begin{cases} 0 & j \neq k \\ N & j = k \end{cases}$
- Each code W_j is either even or odd with respect to its midpoint.

Walsh codes are defined using a Hadamard matrix of order N . The Walsh Code Generator block outputs a row of the Hadamard matrix specified by the Walsh code index, which must be an integer in the range $[0, \dots, N - 1]$. If you set Walsh code index equal to an integer j , the output code has exactly j zero crossings, for $j = 0, 1, \dots, N - 1$ [2][3].

C) PN sequence

A Long PN sequence is uniquely assigned to each user and it is a periodic long code with Period $2^{42} - 1$. There are two reasons for using the long PN sequence

1. Channelization the base station separates forward channel traffic by applying different Sequences to different subscribers.
2. Privacy Each user uses different long codes, and due to the pseudorandom nature of the Codes, hence they are difficult to decode as different sequences are orthogonal to each other.

There are two ways for generating the long PN sequence. One technique uses the Electronic Serial Number (ESN) of the subscriber to generate the long PN sequence and is therefore publicly known if the ESN is known. Another technique generates the long PN sequence Using keys that are known only to the base station and subscriber unit.

IV SIMULATION RESULTS

Fig 3 shows the comparison graph between bit error rate and signal to noise ratio of MC-CDMA Rayleigh channel using Gold codes. The bit error rate for Gold codes in Rayleigh channel for user 2 and user 1 is same but the bit error rate is high. But the main aim of this paper is to get low bit error rates for both the users so in order to overcome this problem other code is considered.

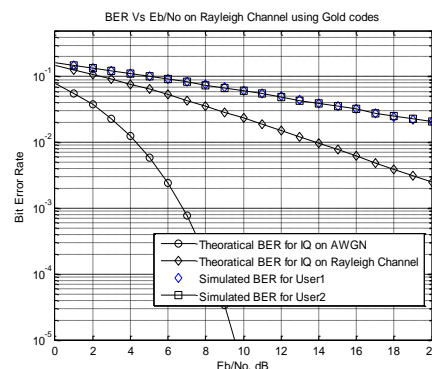

Fig 3 BER Vs E_b/N_0 on Rayleigh Channel using Gold Codes

Fig 4 shows the comparison graph between bit error rate and signal to noise ratio of MC-CDMA Rayleigh channel using Walsh code. The bit error rate for Walsh codes in Rayleigh channel for user 2 is slightly greater than user 1. But the main aim of this paper is to get low bit error rates for both the users so in order to overcome this problem two other codes are considered.

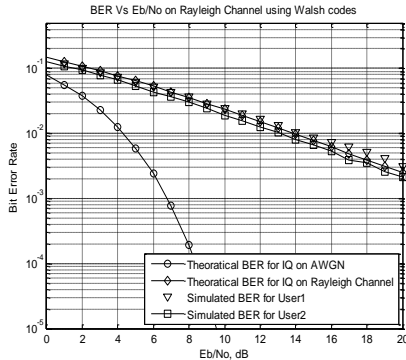

Fig 4 BER Vs E_b/N_0 on Rayleigh Channel using Walsh Codes

Fig 5 shows the comparison graph between bit error rate and signal to noise ratio of MC-CDMA Rayleigh channel using PN Codes. The bit error rate for PN codes in Rayleigh channel for user 2 and user 1 is less. Therefore the best spreading code for performance improvement of MC-CDMA is PN codes.

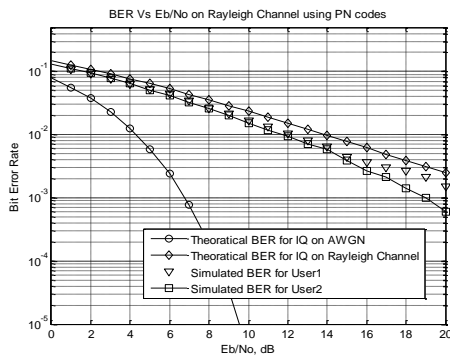

Fig 5 BER Vs E_b/N_0 on Rayleigh Channel using PN Codes

CONCLUSION

In this paper multi-user DS/MC-CDMA (Direct Sequence Multi Carrier- Code Division Multiple Access) modulation scheme that combines the advantages of both OFDM (Orthogonal Frequency Division Multiplexing) and CDMA (Code Division Multiple Access) is studied. The bit error rate performance of DS/MC-CDMA is observed by introducing three different types of spreading codes namely Walsh, Gold and PN codes. The simulation results of the three codes are observed and introducing PN codes in a channel yields best result.

REFERENCES

[1] S. Hara, R. Prasad, "Overview of multicarrier CDMA", IEEE Communications Magazine, Vol. 35, No. 12, pp.126-133, December 1997.
 [2] K. Fazel, S. Kaiser, Multicarrier and Spread Spectrum Systems: From OFDM and MC-CDMA to LTE and WiMAX, 2nd ed., John Wiley & Sons, England, 2008.

[3] S. Nobilet, Helard, D. Mottier, "Spreading sequences for uplink and downlink MC-CDMA Systems: PAPR an MAI minimization" European Transactions on Telecommunications, 2002.
 [4] A.-M. Mourad, A. Gueguen, R. Pyndiah, "Impact of the spreading sequences on the performance of forward link MC-CDMA systems", IEEE 8th International Symposium on Spread Spectrum Techniques and Applications, Vol. 30, pp.683-687, September 2004.