

Performance Analysis of FBG Based Demultiplexer in Optical WDM Systems

Nidhiya Shan

P G Scholar,

Optoelectronics and Communication Systems,

Dept. of ECE

T K M Institute of Technology

Kollam, India

Asha A. S.

Assistant Professor

Dept. of ECE

T K M Institute of Technology

Kollam, India

Abstract— In order to enhance the capacity of optical networks and for increasing the demand of higher bandwidths Wavelength Division Multiplexing(WDM) is used. WDM networks are developed to support multiple signals with different frequencies or wavelengths through a single fiber. The dispersion mechanism within the fiber cause broadening of the transmitted light pulses as they travel along the channel. Inter symbol interference can be compensated by using Optical Fiber Bragg Gratings(FBG). FBG is a type of distributed Bragg reflector constructed in a small segment of an optical fiber that reflects particular wavelengths of light and transmits all other. This work discusses the application of a demultiplexer (DEMUX) based FBG in WDM systems which reduces the bit error rate and enhances the quality of the received optical signal in a network. The performance analysis of the system is done using Optisystem software. The performance of different electrical filters are analyzed by varying chirp functions and data rates.

Keywords: *Wavelength Division Multiplexing, FBG, Filter, Q Factor, bitrates.*

I. INTRODUCTION

Broadband based communication services can provide the technological advancement in telecommunication system. Increasing number of users and bandwidth demands has brought rapid evolution of high speed access networks, which leads to the enhancement of Quality of Service (QoS) and reduces the delays. For better functionality and cost effective implementation a new architecture is required. The requirements such as high data rate and large number of transmission channels have lead to fiber optic data systems. Optical network can provide higher bandwidth than copper based networks.

One of the most promising concepts for high capacity communication system is Wavelength Division Multiplexing (WDM). Wavelength Division Multiplexed optical networks are developed to support multiple signals with different frequencies or wavelengths in a single fiber. WDM is similar to Frequency Division Multiplexing (FDM). But instead of Radio Frequencies (RF), WDM is done in the IR portion of the electromagnetic spectrum. Each IR channel carries several RF signals combined by means of FDM or Time-Division Multiplexing (TDM). Using FDM or TDM in combination

with WDM or several IR channels data of different formats and different speeds can be transmitted through a single fiber. Each multiplexed IR channel is separated, or demultiplexed, into the original signals at the destination. WDM is used for achieving high system capacity and effective usage of bandwidth.

In optical fiber, chromatic dispersion cause significant distortion in optical pulses during transmission. For enhancing the quality of transmission, dispersion compensators are required. Optical Fiber Bragg Gratings (FBG) are used to compensate dispersion. Grating reflects different wavelengths (or frequencies) at different points along its length. The rejected spectrum broadens as the reflected wavelength changes with the grating period. Effectively, a chirped Bragg grating introduces different delays at different frequencies. Chirped gratings are ideally suited to compensate the dispersion for individual wavelengths than multiple wavelengths. Fiber geometry, low insertion loss, high return loss or extinction, and potentially low cost are the advantages of FBG over other technologies.

II. OVERVIEW OF WDM SYSTEM

In fiber-optic communications, Wavelength Division Multiplexing (WDM) is a technology which multiplexes a number of optical carrier signals into a single optical fiber by using different wavelengths of laser light. This technique enables bidirectional communications over one strand of fiber, as well as multiplication of capacity. Since wavelength and frequency are tied together by a simple relationship, in which the product of frequency and wavelength equals the speed of light, the two terms actually describe the same concept.

A WDM system uses a multiplexer at the transmitter to join the signals together and a demultiplexer at the receiver to split them apart. The first WDM systems combined only two signals. Modern systems can handle up to 160 signals.

In an optical fiber, different spectral components propagate at different speed, this is the primary reason for chromatic dispersion. As the consequence of different speeds the light impulse spectral components have different time of

arrival to the end of fiber, impulse width increases and inter-bit spaces narrow. The receiver cannot correctly recognize whether a transmitter in a specific bit interval sent a value of logical one or zero. The distortion of the transmitted information will then increase the bit error rate.

The dispersion can be compensated by Fiber Bragg grating. Fiber Bragg Grating (FBG) is a type of distributed Bragg reflector constructed in a short segment of optical fiber that reflects a particular wavelengths of light and transmits all others. This is achieved by creating a periodic variation in the refractive index of the fiber core. A fiber Bragg grating can therefore be used as an inline optical filter to block certain wavelengths, or as a wavelength-specific reflector.

The fundamental principle behind the operation of FBG is Fresnel reflection, where light traveling between media of different refractive indices may reflect and refract at the interface. The refractive index will typically alternate over a defined length. At each periodic refraction a small amount of light is reflected. All the reflected light signals combine coherently to one large reflection at a particular wavelength when the grating period is approximately half the input light's wavelength. This is referred as the Bragg condition, and the wavelength at which reflection occurs is called the Bragg wavelength. Light signals at wavelengths other than the Bragg wavelength, which are not phase matched, are essentially transparent.

A Bessel filter is a type of analog linear filter with a maximum flat group/phase delay (maximum linear phase response), which preserves the wave shape of filtered signals in the passband. Bessel filters are often used in audio crossover systems. This filter is also called as Bessel-Thomson filters. The Bessel filter is very similar to the Gaussian filter, and tends towards the same shape as filter order increases. The Bessel filter has better shaping factor, flatter phase delay and flatter group delay than a Gaussian of the same order, though the Gaussian has lower time delay.

Chebyshev filters are analog or digital having a steeper roll-off and more passband ripple (type I) or stopband ripple (type II) than Butterworth filters. Chebyshev filters have the property that they minimize the error between the idealized and the actual filter characteristic over the range of the filter, but with ripples in the passband.

The Butterworth filter is a type of signal processing filter designed to flat the frequency response as possible in the passband. It is also referred as a maximally flat magnitude filter. The frequency response of the Butterworth filter is maximum flat (i.e. has no ripples) in the passband and rolls off towards zero in the stopband.

A filter whose impulse response is a Gaussian function. It has the properties of having minimal possible delay. Gaussian filter does not overshoot to a step function input while minimizing the rise time and fall time. It is

considered the ideal time domain filter. A Gaussian filter is non-causal.

Roll-off is the steepness of a transmission function with frequency in electrical network analysis and most especially in connection with filter circuits in the transition between passband and stopband. It is most typically applied to the insertion loss of network. It is used to measure roll-off as a function of frequency. Filters with high roll-off were first developed to prevent crosstalk between adjacent channels on telephone FDM systems.

III. SYSTEM DESIGN

A seven port continuous wave laser source is used to give the input. The transmission frequency of CW laser array starts from 193.1 THz with channel spacing of 25 GHz for the simulation of WDM optical network. The power of the input optical source is -14 dBm. All seven unique subsystems act as WDM transmitters. Multiplexer circuit consists of four subsystems (Tr1 to Tr4). Every subsystem includes NRZ pulse generator, Continuous Wave laser and pseudo random bit sequence generator. The multiplexed signal is then launched into a single mode optical fiber of length 10 km, having an attenuation factor of 0.2 dB/km and a differential group delay of 0.2 ps/km.

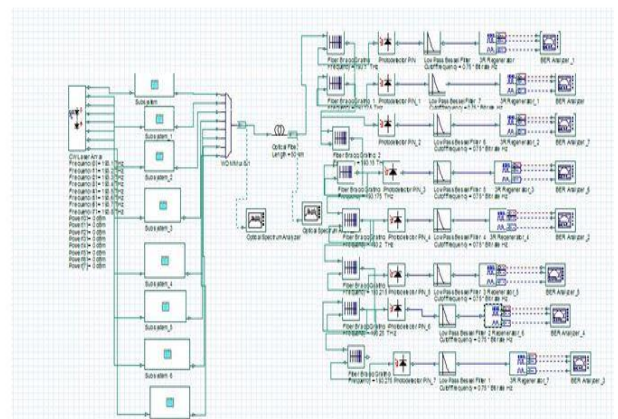

Fig. 1. Circuit diagram of FBG based demux of Bessel filter

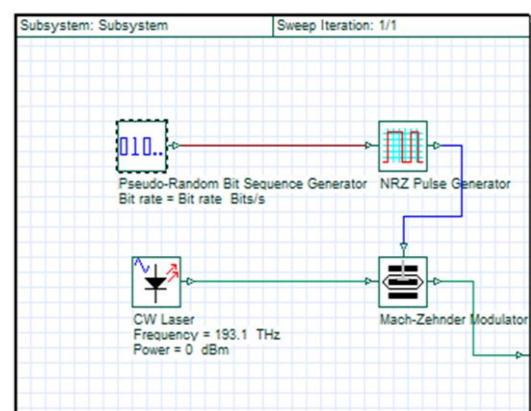

Fig. 2. Internal structure of transmitter subsystem

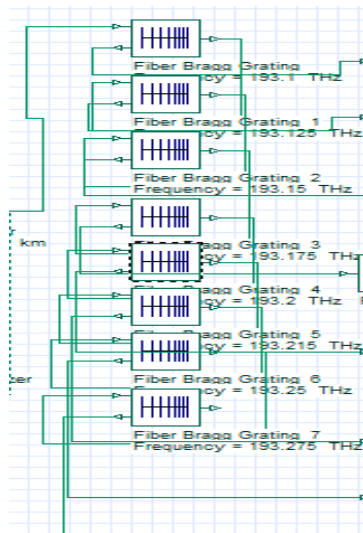

Fig. 3. Internal structure of Demux subsystem

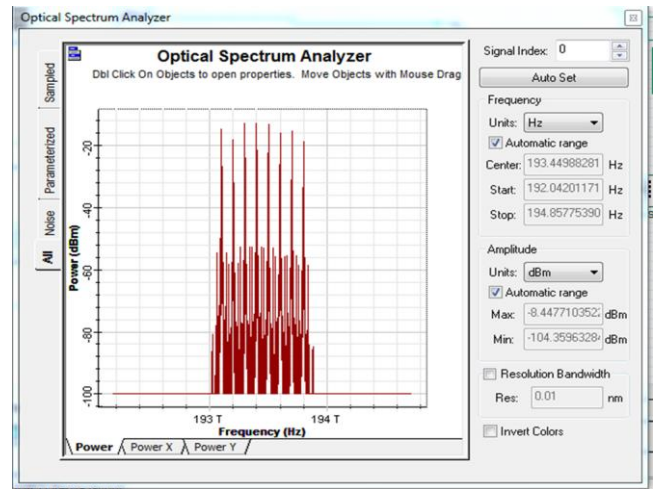

Fig. 4. Input spectrum

The NRZ pulse generator creates a sequence of non-return to zero pulses coded by an input digital signal from the PRBS generator. The optical source used is CW laser. Then the modulated signal is transmitted to the fiber. Output of fiber is sent to fiber Bragg grating which is used to compensate the distortion. The optical signals from the Demux are detected by PIN Photodiode which converts the optical signals to electrical signals. Each incoming signal is then processed by different electrical low pass filters to remove any redundant noise and improve the Bit Error Rate (BER) and the Quality Factor (Q-Factor) of the signal.

The optical signal from fiber is then passed to a FBG based WDM demultiplexer which filters each wavelength. Different low pass electrical filters are used at the end of receiver. The filter in the demultiplexer removes noise from the demultiplexed signals. The optical signals from the demultiplexer are detected by PIN Photodiode which converts the optical signals to electrical signals. Each incoming signal is then processed by low pass Bessel filter to remove any redundant noise and there by improve Quality Factor (Q-Factor) of the signal. The same simulation process is repeated by replacing Bessel filter with Butterworth, Chebyshev, Gaussian, Cosine roll, Raised Cosine and Rectangular filters

IV. RESULTS AND DISCUSSION

The Q-Factor and the BER at the receiver end vary depending upon the electrical filter used. The input spectrum at 1.25Gbps is shown in the figure 4. The values of Q-factor and BER for quadratic, linear and square rootchirp functions at data rates of 1.25 Gbps and 2.5Gbps are given in Table I, Table II and Table III.

TABLE 1 Linear Chirp

FILTER	BIT RATE			
	1.25 Gbps		2.5Gbps	
	Q-Factor	BER	Q-Factor	BER
Bessel	11.428	1.11e ⁻⁰³⁰	11.235	5.67e ⁻⁰³⁰
Butterworth	10.187	1.89e ⁻⁰²⁰	10.987	2.75e ⁻⁰¹⁵
Chebyshev	7.284	1.39e ⁻⁰¹³	7.184	3.067e ⁻⁰¹⁰
Gaussian	9.804	3.67e ⁻⁰²³	10.227	7.284e ⁻⁰²⁵
Cosine Roll Off	9.723	3.62e ⁻⁰²⁷	11.164	2.635e ⁻⁰²⁹
Raised Cosine	8.782	1.11e ⁻⁰¹⁹	9.509	8.179
Rectangular	10.256	4.49e ⁻⁰²⁵	9.668	1.65e ⁻⁰²²

TABLE 2 Square Root Chirp

FILTER	BIT RATE			
	1.25 Gbps		2.5Gbps	
	Q-Factor	BER	Q-Factor	BER
Bessel	13.58	3.19e ⁻⁰²⁶	10.49	4.65e ⁻⁰²⁶
Butterworth	11.871	1.39e ⁻⁰²⁶	9.291	7.39e ⁻⁰²¹
Chebyshev	10.284	8.90e ⁻⁰¹⁴	6.89	2.95e ⁻⁰¹²
Gaussian	9.804	1.5e ⁻⁰²⁴	9.272	8.306e ⁻⁰²¹
Cosine Roll Off	9.723	1.95e ⁻⁰³¹	9.32	4.76e ⁻⁰²¹
Raised Cosine	8.782	2.90e ⁻⁰⁴¹	10.05	4.02e ⁻⁰²⁴
Rectangular	10.256	1.12e ⁻⁰²⁹	9.78	6.38e ⁻⁰²³

TABLE 3 Quadratic Chirp

FILTER	BIT RATE			
	1.25 Gbps		2.5Gbps	
	Q-Factor	BER	Q-Factor	BER
Bessel	12.01	1.99e ⁻⁰²⁴	10.38	1.977e ⁻⁰²⁵
Butterworth	10.33	2.34e ⁻⁰²⁵	8.92	2.100e ⁻⁰¹⁹
Chebyshev	6.95	1.49e ⁻⁰¹²	6.804	4.06e ⁻⁰¹²
Gaussian	9.607	3.18e ⁻⁰²²	8.74	1.134e ⁻⁰¹⁸
Cosine Roll Off	10.25	5.21e ⁻⁰²⁵	8.86	2.79e ⁻⁰¹⁹
Raised Cosine	10.16	9.59e ⁻⁰³⁴	9.96	9.73e ⁻⁰²⁴
Rectangular	10.93	3.53e ⁻⁰²⁸	10.36	3.134e ⁻⁰²⁵

It was observed that at the bit rate of 1.25Gbps, Bessel and Chebyshev filters have highest Q-factor for all the chirp functions. All other electrical filters like Gaussian, Butterworth, and RC are tolerable but possess high BER value. At the bit rate of 2.5Gbps, the electrical filters like Bessel, Gaussian and Cosine Roll-off are having highest value of Q-factor. For linear Chirp function, the Q-factor is found to decrease with the increase in bit rate for most of the filters. The value of BER increases with the increase in bit rate except Rectangular filter. For Quadratic Chirp, the Q-factor increases with increase in bit rate except for Bessel, Butterworth and Chebyshev filters. The value of BER increases with the increase in bit rate except for Rectangular and RC filter. For Square root chirp function, the Q-factor decreases with increase in bit rate except for Cosine Roll off, RC and Rectangular filters. Q-factor gradually increases from Quadratic to linear and then from linear to Square- root Chirp function.

V. CONCLUSION

The performance analysis of various low pass electrical filters like Bessel, Butterworth, Chebyshev, RC, Cosine Roll Off, Gaussian, IIR and Rectangular at different bit rates of 1.25Gbps and 2.5Gbps was done. The Q-factors and BER values of all the filters were tabularized and compared. The performance of Bessel, Butterworth and Chebyshev filters were best among all of the other filters. It was observed that the Bessel filter had the best Q-factor and lowest BER among all the filters for all bit rates. Hence, Bessel filter is the best electrical filter for WDM systems at these bit rates. It was also found that the Quality factor improves with change in Chirp Functions. The best Q factor was attained with square root Chirp Function.

REFERENCES

1. N Sangeetha, Rashi Garg, Surabhi Purwar, Akshita Singh "Performance Analysis of FBG DEMUX based WDM System by Varying Chirp Functions and Data Rates at Different Electrical Filters" *International Journal of Advanced Research in Computer and Communication Engineering*, Vol. 3, Issue 3, March 2014.
2. Saurabh Kumar, Prof. A. K. Jaiswal, Mukesh Kumar, Rohini Saxena "Performance Analysis of Dispersion Compensation in Long Haul Optical Fiber with DCF", *IOSR Journal of Electronics and Communication Engineering (IOSR-JECE)* Volume 6, Issue 6 August 2013.
3. M.A. Othman, M.M. Ismail, H.A. Sulaiman, M.H. Misran, M.A. Meor Said, Y.A. Rahim, A.N. Che Pee, M.R. Motsidi "An Analysis of 10 Gbits/s Optical Transmission System using Fiber Bragg Grating (FBG)", *IOSR Journal of Engineering (IOSRJEN)*, 2250-3021, Volume 2, Issue 7 (July 2012), PP 55-61.
4. Sarah Benameur¹, Christelle, Malika "Impact Of Optical Demultiplexers Based On Fiber Bragg Gratings On DWDM transmission system", *First International Conference on Electrical Engineering and Control Applications ICEECA*, 2012.
5. S. Benameur, M. Kandouci, "Dense Wavelength Division (De) Multiplexers Based on Fiber Bragg Gratings", *Sensors & Transducers*, Vol. 27, May 2014.
6. Oskar Ozolins, Vjaceslavs Bobrovs, Jurgis Porins and Girts Ivanovs "Fiber Bragg Grating Technology for New Generation Optical Access Systems".
7. C. R. Giles "Lightwave Applications of Fiber Bragg Gratings" *Journal Of Lightwave Technology*, Vol. 15, No. 8, August 1997.