

Optimization of Workplace Layout by Using Simplex Method: A Case Study

Kaustubh N. Kalaspurkar, Ravikant V. Paropate, Kapil B. Salve, Vaibhav R. Pannase

Department of Mechanical Engineering^{1, 2, 3, 4}

Jagadamba College of Engineering & Technology, Yavatmal^{1, 4}

Jawaharlal Darda Institute of Engineering & Technology, Yavatmal.^{2, 3}

ABSTRACT:-

Now a day there is competition in market to make available the product in a optimum quantity and within a forecasted dates with a good quality. To fulfill this condition we need to install new quality tools available in market which are costly and forced to uninstall the unnecessary operations. In this paper the case study is discussed which helps to optimize the workplace layout by using method study & Ergonomics for the human comfort. Case study is carried out on Assembly of rear axle carrier of a tractor from Automobile Industry.

Key word:- Time and Motion Study, Workstation Design, Ergonomics, Rear Axle Carrier, Stop Watch.

INTRODUCTION:-

The productivity improvement is the vital part of manufacturing system to satisfy the market demand which will be based on the efficiency of man i.e. operator is highly depending on how well the workstation is designed ergonomically, where as the efficiency of machine is more depends upon its utilization. Whereas the efficiency of both i.e. man and machine is highly affected by methodology adopted in the manufacturing system. As unnecessary and unproductive movements and operation will cause the fatigue to operator as well as improper machine utilization. To analyzed the task in the manufacturing, proper production scheduling is very important.

Time study and motion study is widely used in industries. Time study is defined as 'It is a work measurement technique for recording the times and rates of working for the elements of a specified job carried out under specified conditions, and for analyzing the data so as to determine the time necessary for carrying out the job at a defined level of performance.' Motion study is defined as 'It is the systematic recording and critical examination of existing and proposed ways of doing work, as a means of developing and applying easier and more effective methods and reducing costs.' In the present work, assembly task at one of the leading tractor manufacturing company in India is studied to achieve optimum performance evaluation of the productivity. In the present work the study regarding the workplace layout, number of components involved, movement of workers, available tools and their location etc. were analyzed.

This layout critically analyzed and found the scope of implementation. In reduction to time study we have again analyzed the system in total and divided into parts and tried to record the time for every operation. In flow process chart the analysis of work station has been carried out and in this analysis we found that in critical analysis helped us to remove unwanted activities. Work ergonomics study revealed that the Heart rates and total comfort of worker is higher level as compared to existing one.

Lastly we have tried to check our results through simulation in which we have used Simulation Software and found very satisfactory and incoming result that our suggested techniques reduces time and improve the productivity.

LITERATURE REVIEW:-

A significant amount of research work on Time study and Motion study, Modeling and Simulation, Productivity improvement and Ergonomic study has been published Mr. Gurunath V Shinde 1, Prof.V.S.Jadhav *2, investigate lots of money on man, machine, material, method (4m),improving ergonomics of workplaces is cost saving. Ergonomics found great need when market demand is high and manufacturers need more output within short period. This study was conducted on assembly workstation of welding shop. This work was conducted on an assembly station in welding shop. The shop was facing problem of less efficiency of workers due to poor ergonomics and in some severe cases hazardous health issues are found. This work was conducted on an assembly station in welding shop. The shop was facing problem of less

efficiency of workers due to poor ergonomics and in some severe cases hazardous health issues are found [1]. Baba Md Deros 1 , Nor Kamaliana Khamis 1,Ahmad Rasdan Ismail 2, suggested the concept of high demand for products in the manufacturing industry had driven the human workers to work faster and adapt to their un-ergonomically designed workstation. This study was conducted at an automotive component manufacturer and shows current assembly workstation at company a need to be redesign to eliminate awkward postures and anthropometric mismatches to lower MSDs problem and improve productivity among assembly workers [2]. Mr. Gurunath V. Shinde 1, Prof.V.S.Jadhav 2, identify complex tasks which lead to less efficiency of worker. Various approaches had been develop including direct observations, questionnaires, interview, etc. for ergonomic evaluation of workstation. This technique of ergonomic analysis is very useful to identify complex tasks and root cause of each complex task which is useful in simplifying it and hence to reduce stress on various workers movements [3]. Ibrahim H. Garbie, investigate the effects of assembly of a product on operator performance. Workstations for assembly tasks should be designed so that any operator can adjust to his/her comfort to relieve stress and improve performance. The main contribution of this work has how to measure the production rate of manual assembly lines based on design ergonomically assembly workstation [4]. Paul H.P. Yeowa,_, Rabindra Nath Senb, improving productivity and quality, increasing revenue and reducing rejection cost of the manual component insertion (MCI) lines in a printed circuit assembly (PCA) factory. Live experiments were conducted on production lines. Eleven problems were identified, i.e., long search for materials from the stores, unproductive manual component counting, obstructions during insertions, component fall-off while the PCA board was traveling on a U-shaped conveyor, etc. increasing profit for the company owners, providing price reductions to the customers, and giving large bonus and annual increment to their employees [5].

Ashraf A. Shikdar, Mohamed A. Al-Hadhrami, conducted ‘Smart workstation design: an ergonomics and methods engineering approach’ and this research was to design and develop a smart workstation for performing industrial assembly tasks. A fully adjustable ergonomically designed workstation was developed [6]. Javier Santos_, Jose M. Sarriegi, Nicola´ s Serrano, Jose M. Torres, conducted ‘Using ergonomic software in non-repetitive manufacturing processes: A case study’ This paper uncovers, by means of a case study based on a real process, the advantages and the practical barriers involved in the implementation of 3D simulation tools in SMEs. The chosen case study is based on a non-repetitive manufacturing process [7]. D.

Battini a,* , M. Faccio b, A. Persona a, F. Sgarbossa a, conducted ‘New methodological framework to improve productivity and ergonomics in assembly system design’ this work analyse how ergonomics and assembly system design techniques are intimately related. It also develops a new theoretical framework to assess a concurrent engineering approach to assembly systems design problems, in conjunction with an ergonomics optimization of the workplace. This work provides an extremely valuable methodological framework to companies who recognize the link between assembly and ergonomics [8]. Adi Saptari, Wong Soon Lai, Mohd. Rizal Salleh, conducted ‘Jig Design, Assembly Line Design and Work Station Design and their Effect to Productivity’ the most productive assembly line design which achieved the lowest assembly time is the combination of one operator, with rectangular jig and work station design sitting. This assembly station determines the sequences of operations to manufacture of components as well as the final product [9]. Francesco Longo Giovanni Mirabelli Enrico Papoff, conducted ‘EFFECTIVE DESIGN OF AN ASSEMBLY LINE USING MODELING & SIMULATION’ invented work regarding the effective design of an assembly line for heaters production. The effective design of assembly line workstations by means of integration between ergonomic analyses and Modeling & Simulation. Modeling & simulation in combination with ergonomic analyses is a powerful tool for analyzing assembly line and providing effective design and optimal ergonomic solutions [10].

PROBLEM IDENTIFICATION AND IMPLEMENTATION

For problem identification time study and motion study technique is used. Using this time study and motion study technique time required for each operation is calculated by using stop watch technique for existing setup. After calculating of time for each operation, flow process chart has been prepared. From study of flow process chart the unwanted activity where critically analyzed.

Work study, as it stands today to provide us with a scientific approach to investigation into all form of work, with a view to increase productivity. While many techniques for raising productivity are available today that qualify as a scientific approach, not all of them fall under domain of work study. It is one of the tools in the manager’s tool kit. This is particularly true for work study where the major focus is the investigation of human work, with an aim to improve the efficiency of the same.

This study was conducted at a workstation for the assembly of Rear Axle Carrier. This assembly operation involves 27 components. The entire component was assembled by manual process. The total assembly process was carried out on three different process stations. The assembly of the component of each as follows:

Total parts for assembly station 1

Sr. No.	Name of Part	No. of Parts
1.	Retainer	1
2.	Oil Seal	2
3.	Gasket	1
4.	Axle	1
5.	Ball Bearing (Axle)	1
Total Part for Station 1		6

Table 1:- Total Parts for Station 1

Total parts for assembly station 2

Sr. No	Name of Part	No. of Parts
6.	Circlip (Rear Axle)	1
7.	Pr. Bearing (Carrier)	1
8.	Spacer (Carrier)	1
9.	Carrier	1
10.	Collar	1
11.	Bolts	4
12.	Washer	4

Total Part for Station 2	13
---------------------------------	-----------

Table 2:- Total Parts for Station 2

Total parts for assembly station 3

Sr. No.	Name of Part	No. of Parts
13.	Long D – headed wheel bolt	8
Total Part for Station 3		8

Table 3:- Total Parts for Station 3

Total Part for Station 1, 2 & 3:- $(6+13+8) = 27$.

Assembly process consist of parts of different sizes and weight kept in different bins around the workplace four operators, one operator on workstation 1, two operators on

workstation 2 and one operator workstation 3 are working. The main focus of the study is to find out the task of assembly which leads to high cycle time. Hence each operation involved in the assembly where analyzed critically using time study and motion study. Stop watch technique was used to determine the time for each activity.

ANALYSIS OF WORK PLACE LAYOUT

The existing layout for the assembly of Rear Axle Carrier (RAC) is as shown in Figure 1.

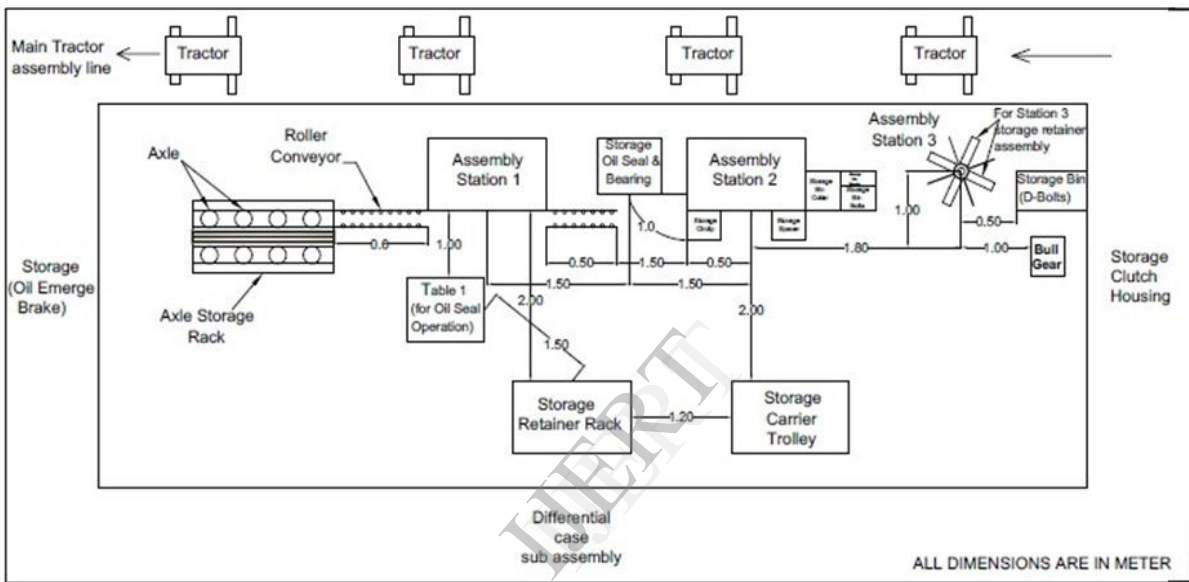

LAYOUT :- REAR AXLE CARRIER ASSEMBLY OF TRACTOR (Existing)

Fig. 1:- Rear Axle Carrier Assembly of Tractor (Existing)

As shown in Figure No. 1 it consists of three in line assembly workstation namely station 1, 2 and 3. Material flow was successive from station 1 to station 2 then from station 2 to station 3. To assist the operator for the material flow roller conveyor (manually operated), and cranes are used.

Assembly operation at station 1 involves the assembly of 6 components as shown in table no.1 out of which retainers are stores in the retainer rack which was located just behind the operator as shown in Fig. No.1. Also the oil seal, gasket, bearing and the axle are located surrounding the workplace as shown in Fig. No.1. During each assembly operator has to move at

each of these locations and collects the parts for the assembly. Similarly the components required assembly station 2 and 3 is to be connected by the operator from the various storage locations surrounding the workplace as shown in the Fig. No.1.

FLOW PROCESS CHARTS

From the above workplace layout and the nature of assembly involved requires several activity at each station 1, 2 and 3. For example at assembly station 1 total 51 activities of the time 6.04 min are involved. At assembly station 2 total 38 activities of the time 5.21 min and 24 activities of the 4.02 min are involves at station 3. Accordingly the flow process chart of the material for each of the assembly station is developed. The sample flow process chart for station 1 is shown in Table No. 4.

FLOW PROCESS CHART - MATERIAL TYPE (STATION 1)

FLOW PROCESS CHART MATERIAL TYPE					
CHART NO.	SHEET NO.	SUMMARY			
Subject charted		ACTIVITY	PRESENT	PROPOSED	SAVING
Used bus engines		OPERATION ○	38	34	04
		TRANSPORT ⇨	08	05	03
ACTIVITY		DELAY □	02	02	-
Stripping cleaning and degreasing prior to inspection		INSPECTION □	01	01	-
METHOD: PRESENT		STORAGE △	02	02	-
		DISTANCE (m)	-	-	-
LOCATION: Degreasing Shop		TIME (man-min)	-	-	-
OPERATIVE(S):	CLOCK Nos.	COST	-	-	-
		LABOUR	-	-	-
CHARTED BY:		MATERIAL	-	-	-
APPROVED BY:	DATE:	TOTAL	-	-	-

DESCRIPTION	QTY	DISTANCE (m)	TIME (sec)	SYMBOL					REMARKS	
				○	⇨	▷	□	△		
1.	Retainer stored in trolley near assembly station 1	-	00							
2.	Pickup the retainer from retainer rack	-	6.82							
3.	Move to table 1	1.5	11.64							
4.	Pickup the oil seal from table 1	-	6.48							
5.	Move retainer and oil seal to assembly station 1	1.0	9.81							
6.	Placed the oil seal on station 1	-	7.79							

TABLE 4:- Sample Flow Process Chart - Material Type (Assembly Station 1)

Similarly material flow process chart for the assembly station 2 and assembly station 3 is also developed. In the same way for Assembly station 1 total 8 readings are taken and the mean is taken as follows:

The mean time required per day is as follows

Day	Time in min
1	5.641
2	5.647
3	5.635
4	5.605
5	5.601
6	5.658
7	5.575
8	5.707
Mean time	5.633 min

Table 5:- Eight reading mean time for assembly station 1

Total mean time required for **station 1 = 5.633 min.**

Similarly **mean time required** for the assembly station 2 and assembly station 3 are determined.

Mean Total time required for the operation =

$$= \text{Time of Station 1} + \text{Time of Station 2} + \text{Time of Station 3}$$

$$= 5.633 + 4.825 + 3.513$$

$$= \mathbf{14.37 \text{ min.}}$$

CRITICAL ANALYSIS BY USING FLOW PROCESS CHARTS

From the above developed flow process chart each of the activity involved at all the 3 station were critically analyzed for the evaluation of the purpose of the each activity. This evaluation is done by finding the answers to the Primary and Secondary questions such as what is achieved through that activity, is that activity is necessary, can it be eliminated, what else might be done etc. from this critically analysis unnecessary and unproductive activities for the

assembly operation at each of the workstation is determined. Accordingly the critical analysis charts for unnecessary and unproductive activities are developed. The sample critical analysis chart for station1 in table no. 6. Similarly critical analysis chart for the assembly station 2 is also developed.

SUBJECT OF CHART: - Rear axle carrier (RAC) assembly station 1, 2 and 3.			
CHART NO. :-			
ACTIVITY	PRIMARY QUESTIONS	SECONDARY QUESTIONS	REMARKS
<u>PURPOSE</u>			
2) Pickup the retainer from retainer rack	<p>What is achieved?</p> <p>➤ Retainer is pickup by the operator from retainer rack and then move up to table 1 from where he pickup the oil seal and move up to station 1 where he place the oil seal on station 1.</p>	<p>What else might be done?</p> <p>➤ The retainer is stored in a bin which is mounted above side of gravity conveyor. This gravity conveyor can be mounting on the left side of assembly station 1 for incoming of retainer on a platform of assembly station 1. Similarly the bin for oil seal can be stored on a right side of assembly station 1 within maximum working area so that operator can pick the incoming retainer with his left hand and oil seal with his right hand simultaneously.</p>	For eliminating the unwanted movement of operator, here we used the gravity conveyor for incoming of retainer and place bin for storing oil seal within maximum area. So we can eliminate the unnecessary motion of the operator and save the production time and can increase productivity.
3) Move to table 1			
4) Pickup the oil seal from table 1	<p>Is the activity necessary?</p> <p>➤ Yes, this activity is necessary for performing the operation for a human operator.</p>		
5) Move retainer and oil seal to assembly station 1			
6) Placed the oil seal on station 1			

TABLE 6:- Sample Critical Analysis Chart (Assembly Station 1)

PROPOSED IMPROVEMENT IN THE WORKPLACE LAYOUT

On the critical analysis for assembly station 1 it was found that activity no. 2, 3, 4, 5, 6, 39, and 40 were unnecessary and can be replaced by making certain suitable arrangement in the workplace layout. For example activity no. 2 to 6 involves movement of the worker from the workstation to the storage location for picking and transporting retainers and oil seals to assembly station 1. This amount of the worker can be eliminated by gravity conveyor for the retainer located near the station 1 which will make constant supply of retainer at the assembly station; similarly special storage bin for the oil seal can be located within the reach of the operator near the assembly station 1. This will eliminate the need of movement of worker for each assembly operation and will result in saving of time. Similarly activity 39 and 40 involved movement and pickup of the bearing of the worker. This unnecessary movement can be eliminated in similar way by making provision of storage bin of bearing nearer to assembly station 1. Similarly for the station 2 and station 3 unnecessary activities were found out and they are eliminated by making required alteration in the workplace. This activity was consuming the total time of 1.481 min. These are tabulated below:

Previous layout:-

From this table it is seen that

Station	Operation No.	Description for Existing layout
Station 1	Operation 2	Pickup the retainer from retainer rack
	Operation 3	Move to table 1
	Operation 4	Pickup the oil seal from table 1
	Operation 5	Move retainer and oil seal to assembly station 1
	Operation 6	Placed the oil seal on station 1
	Operation 39	Pick up the bearing on table 1
	Operation 40	Move bearing to station 1
Station 2	Operation 58	Pick up the bearing from storage (labour 2)
	Operation 59	Move bearing to assembly station 2 (labour 2)

Table 7:- Existing layout unnecessary operation for station 1 and Station 2

Previous layout can be reduced by making the suitable arrangements as:-

By changing previous process as

Station	Operation No.	Description for Actual (Improve) layout
Station 1	Operation 2	By providing the gravity conveyor system near assembly station 1 instead of retainer rack to avoid operation 2 and 3.
	Operation 3	
	Operation 4	This operation is canceled out by providing bin system near assembly station 1. So as to avoid the operation on table 1.
	Operation 5	
	Operation 6	
	Station 1	Operation 39
Operation 40		
Station 2	Operation 58	By providing bin near assembly station 2 to store bearing and subsequently to avoid the operation 58 and 59.
	Operation 59	

Table 8:- Existing layout unnecessary operation for station 1 and Station 2

After critical analysis total **mean time required as given in the table:-**

Day	Time in min
1	1.369
2	1.518
3	1.480
4	1.450
5	1.537
6	1.443
7	1.513
8	1.538
Mean time	1.481 min

Table 9:- Eight reading mean time for assembly station 1 and assembly station 2

After critical analysis total mean time required for **station 1, 2 and 3 = 1.481min.**

From the above suggested changes the proposed improved workplace layout is as shown in Fig. No. 2.

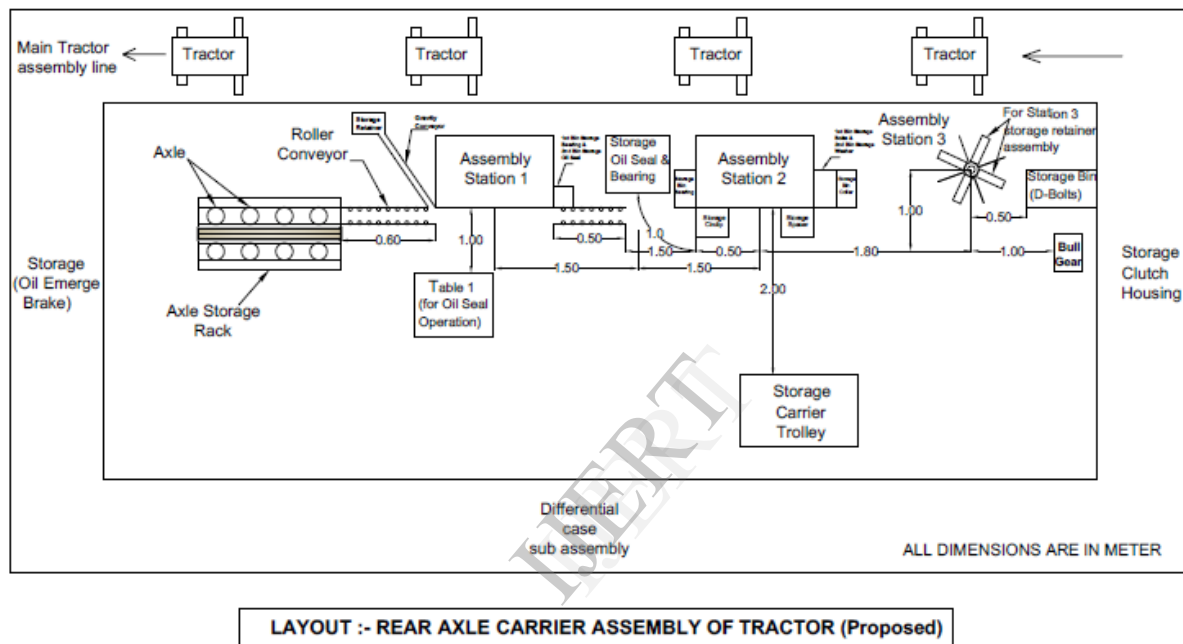

Fig. 2:- Rear Axle Carrier Assembly of Tractor (**Proposed**)

Total time for whole activity by using stop watch = 14.37 min.

Total time after critical analysis which can be reduced = 1.48 min.

Time can be reduced = $14.37 - 1.48 = 12.49$ min.

Previous total time for whole activity (Company Data) = 13.37 min.

Total time save after implementing the suggestion = $13.37 - 12.49 = 48$ sec.

Total time saves for 8 hour shift:-

Total time save after implementing the suggestion for **one** RAC assembly = **48 sec.**

Total time save for assembly of **two** RAC assembly = **1.36 min.**

For 8 hour shift **70 tractors assemble.**

Total time optimize $(1.36 \times 70) = 1 \text{ hour } 35 \text{ min time save for 8 hour shift.}$

ERGONOMICS CONSIDERATION

‘It is scientific, in that Ergonomists measure human characteristics and human function, and establish the way that human body and human mind work. It is also technological, in that the results of scientific work in the human sciences are applied by ergonomists in the solution of practical problems in the design and manufacture of products and system’.

For Ergonomics we have count the Heart Rate of worker. From Heart Rate reading, by using formula we calculate Oxygen Consumption and Energy Consumption reading of worker for Existing Layout. After making some improvement in layout of Existing Rear Axle Carrier (RAC). There is reduction in Heart Rate count and accordingly there is less Oxygen and Energy Consumption. For suggested Proposed Layout of Rear Axle Carrier (RAC). All these location of the suggested bins are kept within the reach of the operator by considering the anthropometric dimension of the operator as shown in Fig. No.3.

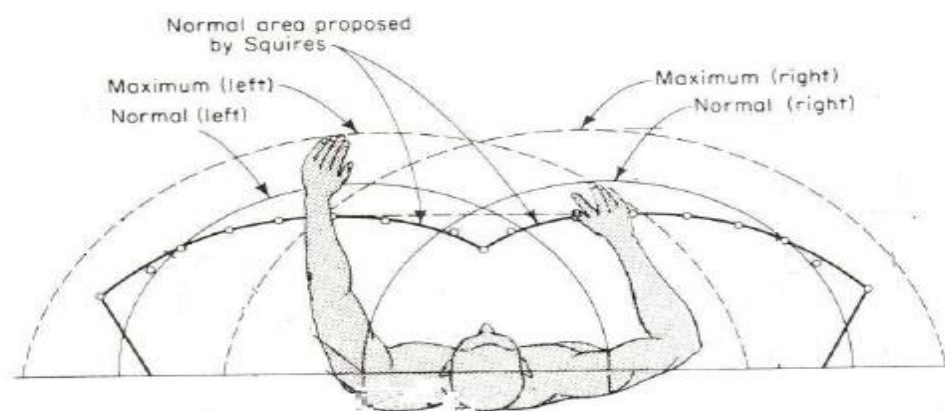

Fig. 3:- Recommended working distance for the arms

For the ergonomic consideration we count the heart rate reading of a worker for both the condition ,after counting it is observed that in the suggested improvement condition the heart rate readings are minimum than previous. Following graph shows the decrease in heart rate of suggested changes in workplace layout of RAC assembly.

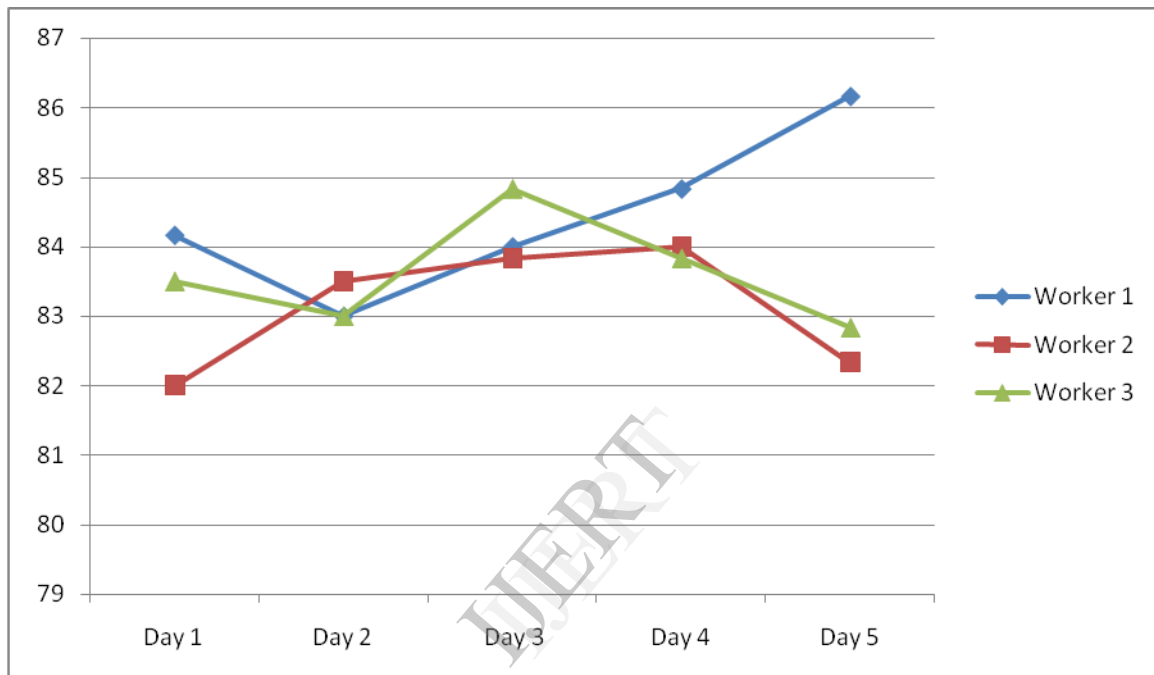

Fig. 4:- Existing condition heart rate reading

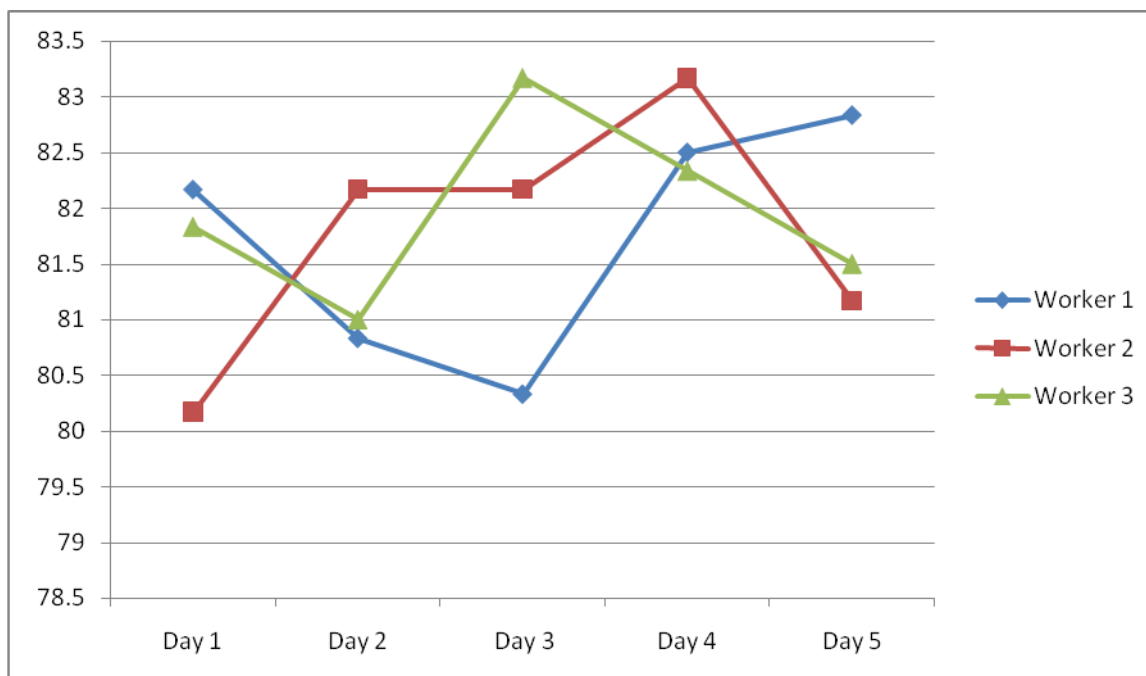

Fig. 5:- Proposed condition heart rate reading

RESULT AND DISCUSSION

OPTIMIZATION THROUGH SIMPLEX METHOD

In the simplex method we have optimize the time for existing work layout and the proposed work layout. The simplex method in which we have obtained the result for minimizing time and improve the production. This result calculated by using simplex method for existing layout and proposed layout.

The optimal solution for existing layout is reached with $S_1 = 0$, $X_1 = 5.633$, and $S_3 = 0$.

$$Z_{\max} = 0 \times 5.39 + 5.633 \times 2.93 + 0 \times 7.78$$

= **16.50**(For existing layout completing operation for assembly station 1 maximum time required is 16.50.)

The optimal solution for proposed layout is reached with $X_1 = 4.5$, $X_2 = 4.32$, and $S_3 = 0$.

$$Z_{\max} = 4.5 \times 1.003 + 4.32 \times 2.06 + 0 \times 1.48$$

= **13.41**(For proposed layout completing operation for assembly station 1 and assembly station 2 maximum time required is 13.41.)

For **existing layout** completing operation for assembly station 1 maximum time required is $Z_{\max} = 16.50$ and for **proposed layout** completing operation for assembly station 1 and assembly station 2 maximum time required is $Z_{\max} = 13.41$. By solving optimization through simplex method we have tried for increasing the production rate for proposed layout.

COMPARISON BETWEEN EXISTING LAYOUT AND PROPOSE LAYOUT BY USING SIMPLEX METHOD

In this present work we have suggested to incorporate new improved layout in which the production rate per day for assembling component for assembly station one and assembly station two is maximize up to certain level without disturbing another assembly station or production layout unit. In this work we have found that the production rate is very much depends on travelling time of assemble component. So by reducing the extra time and extra effort we have found this result for the optimize layout. Overall increases the production rate as compare to existing one.

The time consume in existing layout is maximum as where the time consume in proposed layout is minimum up to a certain level. The existing layout required the maximum time of $Z_{\max} = 16.50$ while for proposed layout it would be found $Z_{\max} = 13.41$.

CONCLUSION

In my project work in which I have theoretically studied time study, motion study and ergonomics on the leading tractor manufacturing company. The result I found in critical analysis is that by the time study and motion study some of the unnecessary operations are combined and modified the flow process in proposed one helps us to reduce time by certain modification in nearby assembly station.

These said modifications in workplace layout are designed ergonomically as well. With this improved layout the total time 48 sec per cycle was found to be reduced. Hence the above result helped us to reduce time and motion ultimately improves production.

LITERATURE CITED:-

- [1] Mr. Gurunath V Shinde¹, Prof. V. S. Jadhav , “Ergonomic analysis of an assembly workstation to identify time consuming and fatigue causing factors using application of motion study”, International Journal of Engineering and Technology (IJET), ISSN : 0975-4024 Vol 4 No 4 Aug Sep 2012.
- [2] 1Baba Md Deros, 1Nor Kamaliana Khamis, 2Ahmad Rasdan Ismail, , “An Ergonomics Study on Assembly Line Workstation Design”, American Journal of Applied Sciences 8 (11): 1195-1201, 2011, ISSN 1546-9239, © 2011 Science Publications.
- [3] Mr. Gurunath V. Shinde¹, Prof. V. S. Jadhav² , “A Computer based novel approach of ergonomic study and analysis of a workstation in a manual process”, International Journal of Engineering Research & Technology (IJERT) Vol. 1 Issue 6, August – 2012, ISSN: 2278-0181.
- [4] Ibrahim H. Garbie, “AN EXPERIMENTAL STUDY ON ASSEMBLY WORKSTATION CONSIDERING ERGONOMICALLY ISSUES”, Proceedings of the 41st International Conference on Computers & Industrial Engineering.
- [5] Yeow P.H.P., Sen R.N., (2006), “Productivity and quality improvements, revenue increment, and rejection cost reduction in the manual component insertion lines through the application of ergonomics” International Journal of Industrial Ergonomics 36:367–377.
- [6] Shikdar A., Al-Hadhrami M.,(2007). “Smart workstation design: an ergonomics and methods engineering approach.” International Journal of Industrial and Systems Engineering. 2(4), 363-374.
- [7] Santos J, Sarriegi J.M.(2007). “Using ergonomic software in non-repetitive manufacturing processes: A case study”. International Journal of Industrial Ergonomics 37: 267-275.

[8] Battini D., Faccio M., (2011), “New methodological framework to improve productivity and ergonomics in assembly system design”, *International Journal of industrial ergonomics* 41 (30-32).

[9] Adi Saptari, Wong Soon Lai, Mohd. Rizal Salleh, “Jig Design, Assembly Line Design and Work Station Design and their Effect to Productivity”, *2011 Jordan Journal of Mechanical and Industrial Engineering. All rights reserved - Volume 5, Number 1 (ISSN 1995-6665)*

[10] Francesco Longo, Giovanni Mirabelli, Enrico Papoff, “EFFECTIVE DESIGN OF AN ASSEMBLY LINE USING MODELING & SIMULATION”, *Proceedings of the 2006 Winter Simulation Conference, L. F. Perrone, F. P. Wieland, J. Liu, B. G. Lawson, D. M. Nicol, and R. M. Fujimoto, eds.*

IJERT