

Optimization and Control of Hybrid Renewable Energy Source Dc Micro-Grid using MATLAB/Simulation

⁽¹⁾Abhay M. Halmare, ⁽²⁾Uday Kumar Shende, ⁽³⁾Rachi Mahendra Sadavarte, ⁽⁴⁾Ankita Pundlik Dukse,

⁽⁵⁾Aditya Madhav Kothare, ⁽⁶⁾Vishal Surendrakumar Dhurve, ⁽⁷⁾Yash Pramod Nanotkar

^(1,2,3,4,5,6,7)Electrical Engineering ⁽¹⁾Assistant Professor, ^(2,3,4,5,6,7)Student,
K.D.K. College of Engineering Nagpur, Maharashtra, India.

Abstract :- Hybrid Renewable Energy Systems (HRES) are increasingly used in both grid-connected and standalone power systems to improve energy reliability and reduce dependence on conventional fuels. However, the use of advanced modulation and optimization methods to evaluate the overall cost-effectiveness of these systems is still limited. This paper investigates different optimization techniques for hybrid energy systems by applying Hybrid Optimization of Multiple Energy Resources (HOMER) and Improved Hybrid Optimization using Genetic Algorithms (IHOGA). A graphical analysis approach based on the Load Coverage Rate (LCR) is also considered to evaluate system performance. The proposed system is modeled and simulated using MATLAB and SIMULINK to study the behavior of photovoltaic, wind, and storage components. A case study based on the energy demand of Building Z at Western Sydney University is used to analyze system performance and power flow management.

Keywords: DC Micro-grid, Renewable Energy, Photovoltaic (PV) System, Wind Energy, Energy Storage System

INTRODUCTION

In present Scenario, role of DC smart grid important role on Traditional Power system. The DC micro-grid system, as a subsystem of the smart grid system, can also incorporate the smart concept into the DC power distribution for smart energy delivery . Proposed micro-grid system is connected with the 230V AC power source, sources such as PV system, Wind system, the AC source. The battery and ultra capacitor are used as the main energy storage sources all together, form DC micro grid for smart energy delivery.. Hence, the proposed DC micro-grid system can not only provide the high quality power for three types of DC and AC loads, but also achieve many special features and characteristics for smart energy delivery.

However, since the smart concept for modern grid is under development, the DC micro-grid system still limits in the traditional configuration. Also, there are very few reports on the new DC micro-grid for practical application. Although the

presents a new DC micro-grid for high power quality distribution, the renewable energy is not modeled into the grid system. Hence, it is still a conventional model for the DC grid system. A new DC micro-grid system is proposed for the smart energy delivery. The proposed micro-grid system is connected with the 415V AC power source, and integrates the renewable energy sources of wind power and photovoltaic (PV) power, as well as the electric vehicle together. In addition, the proposed DC grid system adopts the battery, ultracapacitor and EV for the energy storage. proposed test system with Buck converter and Zeta converter connected to the three phase grid, it is clear that the test system with Zeta converter has better performance as compared to conventional Buck converter. This project will give a detail discussion of the system configuration, system control strategy for smart energy delivery, and the corresponding simulation performance.

LITERATURE REVIEW

The rapid growth of energy demand and environmental concerns has increased the interest in renewable energy systems and smart grid technologies. Researchers have focused on developing efficient micro-grid and hybrid renewable energy systems that can integrate multiple energy sources while ensuring reliable and high-quality power supply. Several studies have investigated different configurations, optimization techniques, and control strategies to improve the performance and efficiency of these systems.

Liu et al. proposed a new DC micro-grid system that integrates renewable energy sources and electric vehicles for smart energy delivery. The system combines various modules such as AC supply, renewable energy sources, storage systems, standby generators, and intelligent control mechanisms. This integrated structure allows the micro-grid to distribute energy efficiently to different types of loads, including AC and DC loads. The authors emphasized that the DC micro-grid architecture improves power quality because DC systems eliminate harmonic issues that are typically present in AC distribution networks. In addition, the use of a common DC link simplifies the system configuration and increases overall energy efficiency.

One of the important aspects discussed in the literature is the integration of renewable energy sources such as photovoltaic (PV) and wind power. Renewable sources are environmentally friendly and help reduce dependency on fossil fuels. However, they are inherently intermittent because their output depends on weather conditions. Liu et al. addressed this challenge by combining PV panels and wind turbines within the same micro-grid system. The complementary nature of these sources allows the system to generate power during different periods of the day. For example, solar energy is typically available during the daytime, while wind energy can be stronger during nighttime or cloudy conditions. This combination increases the reliability of renewable energy supply within the grid.

Energy storage also plays a critical role in maintaining system stability. The proposed DC micro-grid system incorporates batteries, ultracapacitors, and electric vehicles as energy storage units. Batteries provide long-term energy storage, while ultracapacitors offer high power density for quick energy exchange. Electric vehicles are also considered as an additional storage resource that can either consume energy from the grid or supply energy back to it through bidirectional converters. This concept improves energy management and enhances the flexibility of the system. Through intelligent control strategies, the stored energy can be used to support the load during peak demand periods or when renewable generation is insufficient.

Another important contribution in the literature is the development of control strategies for smart energy delivery. The DC micro-grid system operates under multiple modes depending on the availability of energy sources. These modes include AC energy delivery mode, renewable energy delivery mode, hybrid energy delivery mode, and standby energy delivery mode. Each mode manages the power flow between energy sources, storage systems, and loads. For example, during periods when renewable energy is unavailable, the AC supply module provides power to maintain system stability. In contrast, when renewable energy generation is sufficient, the grid prioritizes renewable sources and stores excess energy in batteries or other storage units. This intelligent energy management approach improves system efficiency and reduces reliance on conventional energy sources.

In addition to micro-grid design, several studies have focused on hybrid renewable energy systems (HRES) that combine different renewable technologies to achieve higher reliability and cost efficiency. Trape and Hellany studied the design and optimization of hybrid renewable systems that integrate wind turbines, photovoltaic panels, and energy storage units. Their research highlighted the importance of optimizing system size and configuration in order to minimize energy costs and improve system performance. The authors used optimization

tools such as HOMER and IHOGA to evaluate the performance of different system configurations. These tools analyze technical and financial parameters to determine the most efficient design for a given load demand.

A major challenge in hybrid systems is balancing energy production with load demand. Renewable energy sources do not always produce power at a constant rate, so it is necessary to analyze load characteristics and energy consumption patterns. Trape and Hellany introduced the concept of Load Coverage Rate (LCR) to measure how much of the load demand can be satisfied by renewable energy sources. A higher LCR indicates that the system can operate more independently from the main grid. Their study showed that combining wind, solar, and storage systems significantly improves load coverage and reduces the dependency on conventional grid power.

Simulation and modeling tools are widely used in renewable energy research to evaluate system performance before practical implementation. In the literature, MATLAB and Simulink are commonly used for system modeling and analysis. Trape and Hellany developed simulation models for both photovoltaic and wind turbine systems to analyze parameters such as power output, voltage stability, and system efficiency. The simulation results revealed certain technical challenges, including voltage ripple and frequency stabilization issues, which must be addressed through proper control techniques and filtering mechanisms. These studies demonstrate that simulation plays a crucial role in designing reliable and efficient hybrid energy systems.

Overall, the reviewed literature shows that DC micro-grids and hybrid renewable energy systems are promising solutions for modern power distribution networks. The integration of renewable sources, energy storage systems, and intelligent control strategies can significantly improve energy efficiency, reliability, and sustainability. Furthermore, optimization techniques and simulation tools help researchers design systems that are both technically efficient and economically viable. Future research may focus on improving energy storage technologies, developing more advanced control algorithms, and enhancing the integration of electric vehicles into micro-grid systems.

RESEARCH & OBJECT

The objectives of this project are as follows:

1. To study and design the Photovoltaic System.
2. To study and design Wind System.
3. To study and design ac System.
4. Design a DC micro-grids for getting constant and smooth DC output.
5. To study and design simulation of complete hybrid system.

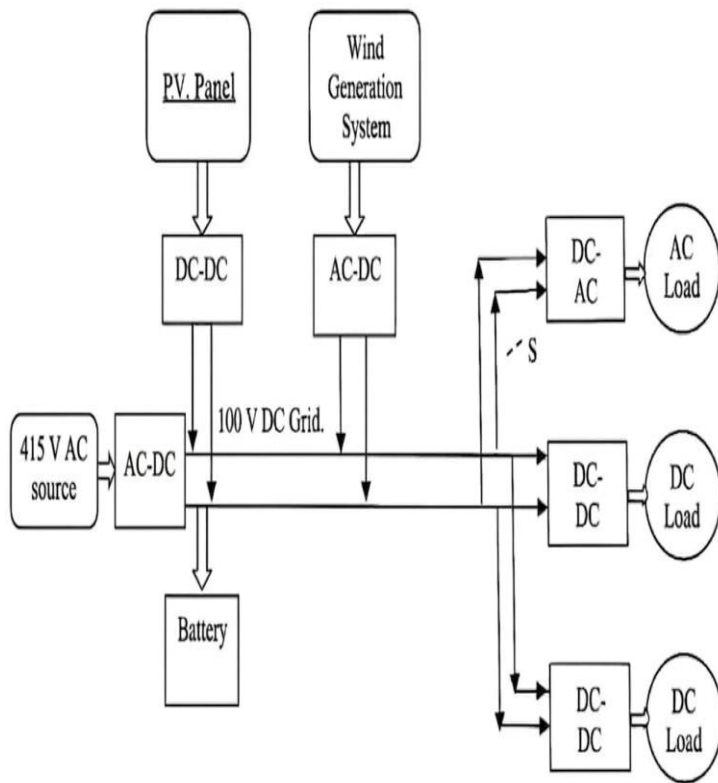

Figure 1: Block Diagram of Proposed System

1.1 Energy Generation Sources P.V. Panel: Converts sunlight directly into DC electricity. Its output changes with solar intensity, so it needs a converter to match the grid voltage.

Wind Generation System: Uses a turbine to turn kinetic wind energy into AC electricity. Since wind speed varies, the frequency and voltage of this AC power change and need processing.

415 V AC Source: This is the main utility grid. It acts as a backup to supply power when renewable generation is low or the battery is empty.

1.2. Power Electronic Converters (The Interface) DC-DC (connected to PV): Usually a Boost Converter. It increases the variable DC voltage from the PV panels to the constant 100 V needed by the DC grid. This often includes MPPT (Maximum Power Point Tracking) logic to get the most power possible.

AC-DC (connected to Wind): A Rectifier. It changes the variable AC from the wind turbine into a stable DC voltage for the grid.

AC-DC (connected to 415V Source): A Step-down Rectifier/Transformer unit. It converts high-voltage utility AC to 100 V DC. It can also be bidirectional if your project allows for selling power back to the grid.

1.3. Energy Storage & Grid 100 V DC Grid: This is the backbone or Common DC Bus. All sources feed into this line, and all loads draw from it.

Battery: Acts as the energy buffer. It stores extra energy during peak production (sunny or windy times) and releases it when generation is low. In MATLAB, you would likely model this using a Bidirectional DC-DC Converter to control charging and discharging.

1.4. Load Distribution DC-AC Converter: An Inverter. It changes the 100 V DC back into AC to power standard household or industrial AC loads. DC-DC Converters (connected to DC Loads): These are Buck Converters. They reduce the 100 V grid voltage to lower DC levels (like 12V, 24V, or 48V) that are suitable for specific DC appliances or electronics.

Switch (S): This is a protection or isolation switch, allowing the system to disconnect specific load branches for maintenance or during a fault.

EXISTING SYSTEM

India has developed a diverse and rapidly expanding renewable energy ecosystem to meet its growing power demand while reducing dependence on fossil fuels and lowering carbon emissions. The country's renewable energy portfolio is dominated by solar energy, which has emerged as the fastest-growing segment due to India's high solar insolation and strong government initiatives such as large-scale solar parks and rooftop installations. Wind energy also plays a significant role, particularly in states like Tamil Nadu, Gujarat, and Maharashtra, where favorable wind conditions support large onshore wind farms. Hydropower remains one of the oldest and most reliable renewable sources, contributing both large-scale generation through dams and smaller decentralized systems that enhance rural electrification and grid stability. In addition, biomass energy utilizes agricultural residues, animal waste, and industrial by-products like bagasse to generate electricity, making it especially important for rural and agro-based economies. Waste-to-energy systems are also being implemented in urban areas to convert municipal solid waste into usable power, addressing both energy needs and waste management challenges. Furthermore, India is increasingly investing in emerging renewable technologies such as hybrid solar-wind systems, battery energy storage systems, pumped storage hydro, and green hydrogen to improve reliability and ensure round-the-clock clean energy supply. Overall, India's renewable energy systems reflect a balanced mix of traditional and modern technologies, supported by policy frameworks and technological advancements, positioning the country as a global leader in the transition toward sustainable energy. Existing Hybrid system with Solar and other sources use conventional DC boost converter Proposed System Use. When designing solar power based individual system many different factors are taken into account: installation location, annual solar insolation, tilt angle of modules, number of solar modules, ambient temperature, shading, natural cooling of modules.

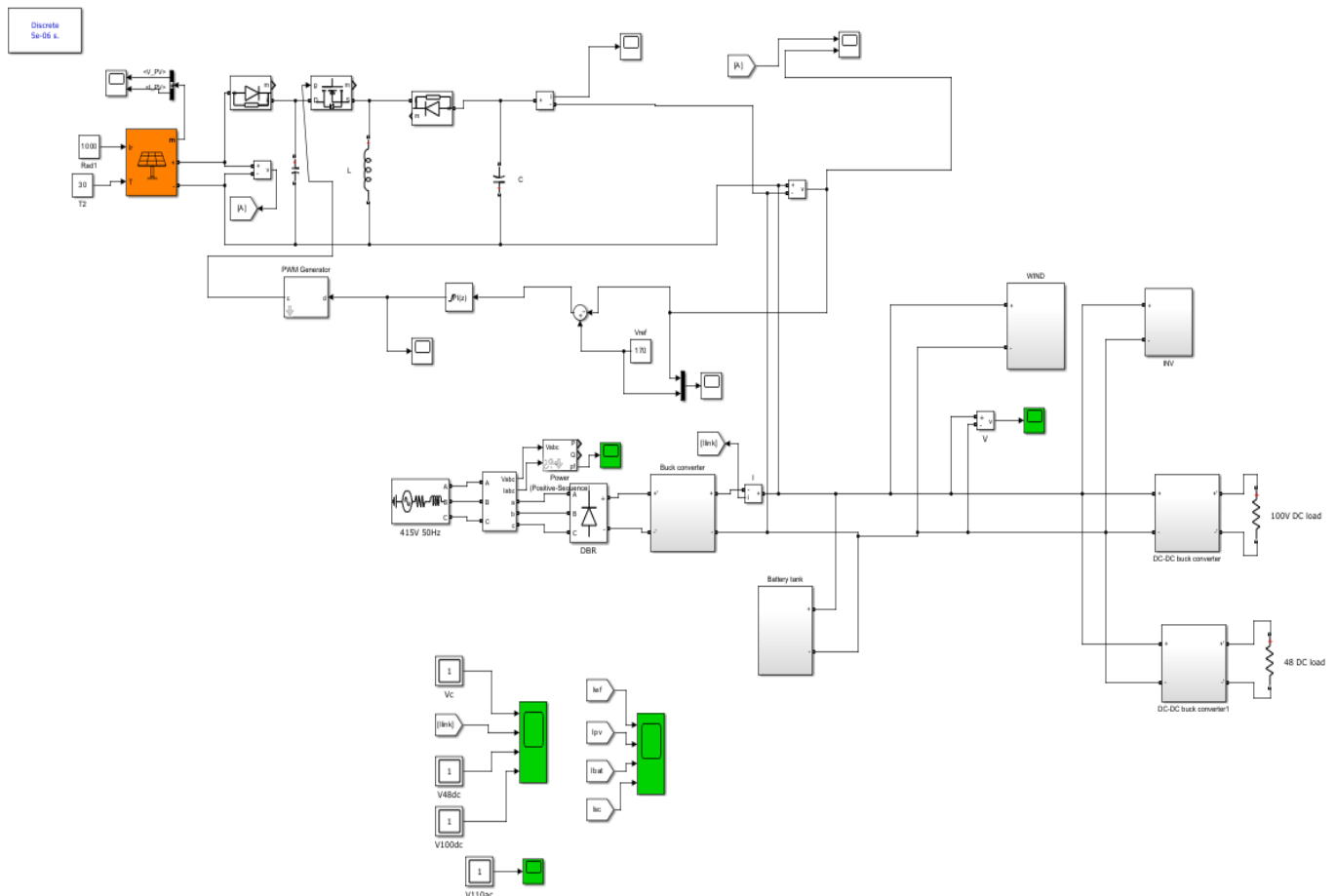

The proposed system is a hybrid renewable energy system that integrates solar photovoltaic (PV), wind energy, battery storage, and grid supply to provide a reliable and continuous power supply to DC loads. The solar PV module converts solar irradiance into electrical energy, whose output is inherently variable and dependent on environmental conditions such as temperature and sunlight. To extract maximum power from the PV system, a DC-DC boost converter controlled by a PWM generator is used, which can be extended to implement Maximum Power Point Tracking (MPPT) techniques. The boosted DC output is then fed into a common DC bus.

In parallel, the wind energy system generates electrical power based on wind speed. The output of the wind generator is conditioned and integrated into the same DC bus, ensuring multiple renewable sources contribute simultaneously. Additionally, a three-phase AC grid (415V, 50 Hz) is connected through a rectifier and power electronic converter to provide backup power and maintain system stability when renewable generation is insufficient.

A battery energy storage system is connected to the DC bus through a bidirectional DC-DC converter. This battery plays a crucial role in energy management by storing excess energy during high generation periods and supplying power during low generation or high demand conditions. The system maintains a stable DC bus voltage using control mechanisms and feedback loops.

Finally, DC-DC buck converters are used to supply regulated voltages (such as 100V and 48V) to different DC loads. These converters ensure proper voltage regulation and efficient power delivery. Overall, the system improves reliability, reduces dependency on conventional sources, and enhances energy efficiency by combining multiple renewable sources with intelligent control and storage.

Overall, the hybrid renewable energy system offers significant advantages such as improved reliability, enhanced efficiency, reduced dependency on fossil fuels, and better utilization of renewable resources. By integrating multiple energy sources with storage and advanced control techniques, the system ensures continuous and stable power supply, making it highly suitable for modern sustainable energy applications.

RESULT & DISCUSSION

The proposed DC micro-grid system with integration of photovoltaic, wind system, battery, and ultracapacitor has been successfully designed and simulated. It has been observed that the proposed DC micro-grid system can efficiently convert the given 415 V AC into stable DC power with the help of a diode bridge rectifier and DC-DC converters. Moreover, it has been observed from the simulation results that the proposed DC micro-grid system can efficiently provide stable outputs at 110 V AC, 100 V DC, and 48 V DC for different types of loads.

The proposed DC micro-grid system with integration of renewable energy sources can efficiently improve the reliability and efficiency of the micro-grid system. Moreover, the proposed DC micro-grid system can efficiently maintain continuous power supply with the help of energy storage devices like battery and ultracapacitor.

CONCLUSION

The proposed DC microgrid design integrates various energy sources effectively. These sources include the AC utility grid, renewable energy, a diesel generator, a battery energy storage system, and electric vehicle (EV) charging infrastructure. The coordinated operation of these different sources improves system flexibility, reliability, and energy efficiency. This makes the microgrid suitable for modern smart energy applications. The system operates in four distinct modes: AC mode, Renewable mode, Hybrid mode, and Standby mode. This setup ensures an uninterrupted power supply under various operating and load conditions. In all modes, the DC link voltage is maintained at 170 V, showing strong voltage stability and effective control strategies. This stable DC bus is crucial for seamless power sharing among sources and loads, which helps minimize power quality issues. Additionally, the proposed microgrid delivers high-quality power to different load types. This includes 110 V AC loads as well as 100 V DC and 48 V DC loads. The ability to support both AC and DC loads at the same time highlights the system's versatility. It also reduces the need for extra power conversion stages, thus improving overall system efficiency and lowering conversion losses. Thorough simulation studies have been conducted to assess the performance of the proposed DC microgrid in different operational scenarios. The simulation results show smooth power flow management, minimal voltage fluctuations, and efficient load sharing among the available energy sources. The system also reliably delivers energy, even during source transitions and changing load demands, demonstrating the effectiveness of the control strategy. In summary, the simulation results confirm that the proposed DC

microgrid offers a reliable, stable, and efficient solution for integrating renewable energy sources, traditional generation, energy storage, and EV systems. These outcomes validate the architecture's feasibility for future smart grid and sustainable energy applications.

REFERENCES

- [1] Luis E. Zubieta, "Demonstration of a microgrid based on a DC bus backbone at an industrial building", DC Microgrids (ICDCM) 2017 IEEE Second International Conference on, pp. 235-241, 2017
- [2] Control of Bidirectional Quadratic DC-DC Converters for Storage Support of DC Power Grids, 2018 7th International Conference on Renewable Energy
- [3] S. Puchalapalli and B. Singh, "A Grid Interactive Microgrid Based on Wind Driven DFIG and Solar PV Array with Regulated Power Flow Functionality," 2018 8th IEEE India International Conference on Power Electronics (ICPE), JAIPUR, India, 2018, pp. 1-6,
- [4] A. Vojdani, "Smart integration," IEEE Power and Energy Magazine, Vol. 6. No. 6, pp. 71-79, Nov/Dec. 2008,
- [5] A. Ipakchi and F. Albuych, "Grid of the future," IEEE Power and Energy Magazine, Vol. 7. No. 2, pp. 52-62, Jan. 2010.
- [6] H. Kakigano, Y. Miura, T. Ise, and R. Uchida, "De voltage control of the DC micro-grid for super high quality distribution," Power Conversion Conference, Nagoya, pp. 518-525, 2007.
- [7] M. Brenna, C. Bulac, G.C. Lazaroiu, G. Superti-Furga, and E. Tironi, "DC power delivery in distributed generation systems," 13th International Conf. on Harmonics and quality of Power, pp. 1-6, 2008.
- [8] Y. Fan, K.T. Chau and M. Cheng, "A new three-phase doubly salient permanent magnet machine for wind power generation," IEEE Transactions on Industry Applications, Vol. 42, No. 1.. pp. 53-60, January/February 2006.
- [9] Y. Fan, K.T. Chau and S. Niu, "Development of a new brushless doubly fed doubly salient machine for wind power generation, IEEE Transactions on Magnetics, Vol. 42, No. 10, pp. 3455-3457, Oct. 2006.
- [10] K.T. Chau, Y.B. Li, J.Z. Jiang and S. Niu, "Design and control of a PM brushless hybrid generator for wind power application," IEEE Trans. on Magnetics, Vol. 42, No. 10, pp. 3497-3499, Oct. 2006.