

Off-Grid Power Generation in Agricultural Farm with Self Excited Induction Generator using Microcontroller based Pico-Hydro System

Mr. Chougule Prashant S.

Department of Electrical Engineering
Vishveshwarya Technical Campus, Patgaon, Miraj
Sangli, India

Miss. Hegannawar Poonam D.

Department of Electrical Engineering
Vishveshwarya Technical Campus, Patgaon, Miraj
Sangli, India

Miss. Patil Amruta S.

Department of Electrical Engineering
Vishveshwarya Technical Campus, Patgaon, Miraj
Sangli, India

Mr. Joshi Pratik. N.

Department of Electrical Engineering
Vishveshwarya Technical Campus, Patgaon, Miraj
Sangli, India

Abstract— As per the instructions specified in ‘Conditions of Supply Based on the Maharashtra Electricity Regulatory Commission Regulations, 2005’, independent electrical connections are necessary for domestic and non-domestic purposes. This imposes major economic burden on farmers living far away from the utility distribution line. The experimental setup using 3 phase induction motor as a self-excited induction generator having delta connected capacitors on stator end with least initial and running cost was installed on one such site. The proposed system uses motor-fan as pelton-wheel turbine with least technical glitches to facilitate practical implementation by farmers directly. Water which is pumped by the water pump from nearby canal/ well/ lake can be used as source to drive the turbine. The laboratory results are conditionally matching with the on-site results. So, the method can be used for rural temporary electrification purposes economically. The microprocessor based electronic circuitry required to change the capacitance with respect to variation in load is also designed for the given system.

Keywords— SEIG; Microcontroller; Off-grid power generation ; Pico-Hydro System

I. INTRODUCTION

Nowadays, due to increase in demand of electricity off-grid electrification has got importance in the recent past. The off-grid electricity generation has various options such as renewable energy source based generation. The renewable energy source based generation such as Pico-hydro power system can be used in rural and hilly regions and also in irrigation systems in farms.

Separate independent electrical connections are necessary for domestic and non-domestic purposes in state like Maharashtra as per the instructions specified in MERC, Government of Maharashtra. [1] The lighting loads on farm sites are occasionally used. Drawing separate connection for lighting may not be practical for farmers living away from the distribution line. The Pico-hydro systems by means of synchronous machine or induction machine can be installed on such locations. The Pico-hydro power system gives maximum electrical output up to five kilowatts (5kW). [2] The Pico-hydro power plant has benefit in terms of simplicity,

cost, design, planning and installation as compared to other systems. The induction machine is preferred in because of its wider availability, maintenance free operation and cost-effectiveness. The water from the well in the farm is forced on the turbine blades through the piping system. [3] [4] The turbine rotates the rotor of induction machine and electricity is generated. The reactive power is consumed by an induction generator and the active power is delivered to load. In this system, the reactive power is fed externally by means of capacitor for core magnetization and for developing terminal voltage [5].

II. DESIGN OF PICO-HYDRO SYSTEM

A. Selection of motor as generator

The 3 phase 2 HP induction motor is selected due to its advantages such as robustness, simple construction, ease of availability and it is cheaper for low power rating (up to 10kW). The squirrel cage induction motor is selected over the wound rotor as the wound rotor is more expensive and less robust. The 3 phase self excited induction generators are widely used for Pico-hydro system as the 3 phase variety is more common. [3] DC generator can be used if energy storage (battery charging) is to be done.

B. Design of turbine

Selection of turbine is based on speed range and power capacity of AC generator. The reaction turbine is to be fully immersed in water and enclosed in pressure casing. The impulse turbine does not require pressure casing and it can operate in air and works with high speed jet of water. The pelton wheel turbine is used because its operation is not restricted to high speed, but if power transmitted is low, and then it will also run on low heads. A small scale pelton turbine is fabricated for carrying out on-site experiments.



Fig. 1. Pelton wheel turbine with 6 blades

The turbine with 6 blades fabricated from polyvinyl chloride (PVC) as shown in fig. (1) is used in proposed system. The motor –fan disc is used as shaft base. The HD PVC pipe of 1.5 inch diameter is used to make blades as it is less expensive and does not require specialist to fabricate the turbine blades.

C. Generator-capacitor Configuration

The delta connected capacitor (fig. 2) is used as the star connection of capacitor requires three times capacitance than for delta connection of capacitor. With the star-delta configuration we can get the output power above 300 watts and efficiency up to 67%. With this configuration the winding currents are also within the rated range.

D. Site Selection

By using this system we generate electricity in farm where water from well is used as a source. The readings are taken on a nearby farm as shown in fig. (3). The water from the well is pumped and forced on the turbine through piping system with the help of nozzle. The nozzle is used to get the sufficient water pressure.

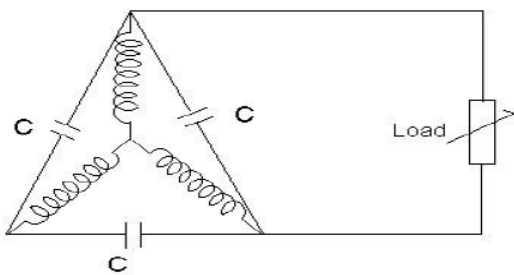

Fig. 2. Delta-connected capacitor configuration



Fig. 3. Onsite experimental setup

III. RESULTS

A. Laboratory setup readings

TABLE I. FOR C = 40µF

Sr. No	Load (Watts)	Speed (RPM)	Generated Voltage (Volts)
1	0	691	189
2	60	700	169
3	100	718	170
4	200	752	171

TABLE II. FOR C = 55µF

Sr. No	Load (Watts)	Speed (RPM)	Generated Voltage (Volts)
1	0	633	190
2	60	618	168
3	100	640	170
4	200	670	170

B. Onsite Readings

TABLE III. FOR C = 40µF

Sr. No	Load (Watts)	Speed (RPM)	Generated Voltage (Volts)
1	0	664	125
2	60	668	98
3	100	703	84
4	200	770	58

TABLE IV. FOR C = 55µF

Sr. No	Load (Watts)	Speed (RPM)	Generated Voltage (Volts)
1	0	575	111
2	60	591	93
3	100	604	84
4	200	636	70

IV. INTERPRETATION FROM REULTS & PROPOSED SYSTEM

From the table no I to IV, we can conclude that while taking readings in lab the voltage remains almost constant but for onsite readings the voltage decreases as the load increases. We have to maintain the voltage constant. A microcontroller and relay circuit is used for keeping the voltage constant at a particular value in case of load variation.

The block diagram using microcontroller and relay circuit is as shown in the fig. (4). The AC output voltage from the induction generator is converted into DC with the help of 3 phase diode rectifier [6]. The DC output can be used for emergency lighting and battery charging. The voltage is sensed using voltage sensor which is a voltage divider network.

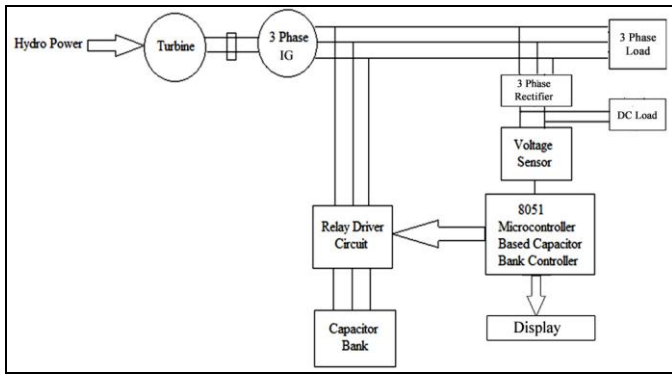

Fig. 4. Block diagram of microcontroller-based relay operated capacitor switching

After lab readings and on-site experiments, the microcontroller based system is designed for getting DC 230V output constant with tolerance band of 4%. The switching of relays will effectively change the capacitor on stator terminal of induction generator till the voltage profile is maintained to desired results. This sensed voltage is given to microcontroller AT89C51 [7]. The reference voltage is set into the microcontroller through the program. The reference voltage is compared with the generator output voltage and according to that the microcontroller will switch the capacitors to the generator terminals by using the relay circuit. The DC terminal voltage is displayed on LCD by the microcontroller. The simulation and physical hardware of the capacitor switching circuit of the same circuit is shown in fig. (5) and fig. (6) respectively.

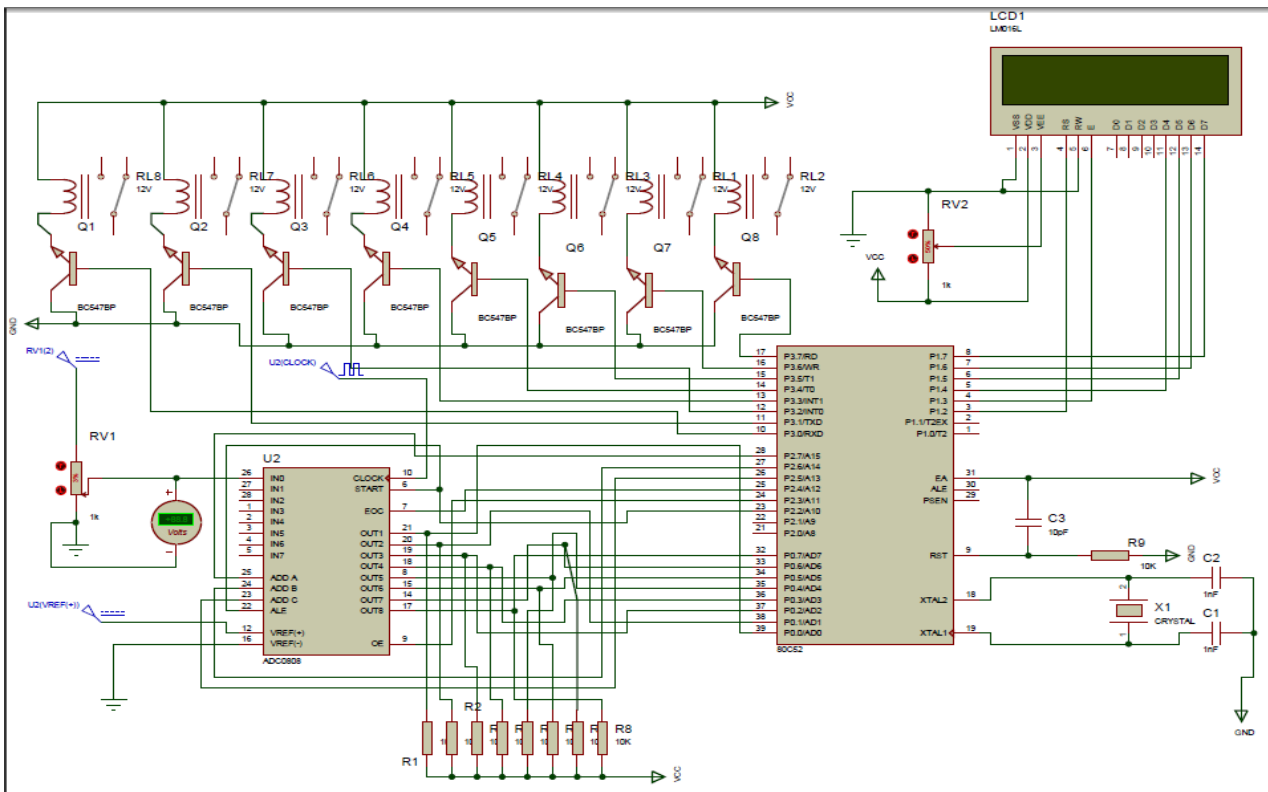

Fig 5 Simulation circuit of microcontroller-based relay operated capacitor switching

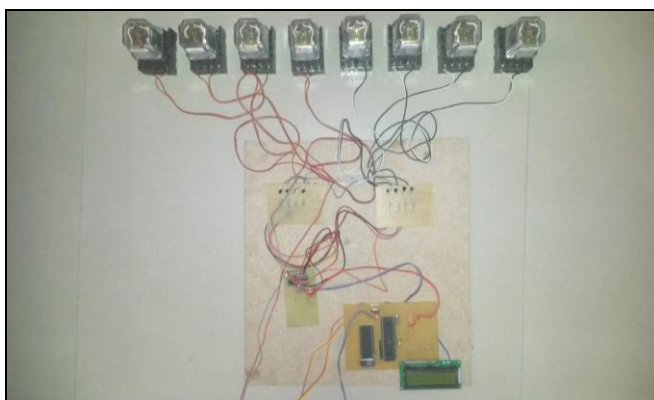

Fig 6. Hardware Circuit of microcontroller-based relay operated capacitor switching conclusion

CONCLUSION

The results obtained from onsite experiment clearly indicate that with the increase in load, the voltage profile of the system is disturbed due to input torque limitations as compared with the lab. The scheme is most useful for DC load as compared with 3 phase AC load because of variation in frequency due to capacitor switching.

The microcontroller based relay operated capacitor switching scheme can be implemented for given experimental setup for smooth variation of capacitors for variable load conditions thereby allowing using induction machine as a generator in Pico-hydro system. The same can be implemented for variable speed input systems with little changes in microcontroller code.

ACKNOWLEDGMENT

For our pleasure, we are presenting deepest gratitude towards all those who have contributed their valuable efforts and time directly and indirectly in completing our project work as curricular activity. We express our sincere gratitude towards all the facilities offered in the institute. We have unhesitatingly approached our faculty members for guidelines for preparing project.

REFERENCES

- [1] Resolution, Government of Maharashtra, "Conditions of Supply Based On the Maharashtra Electricity Regulatory Commission (Electricity Supply Code & Other Conditions of Supply) Regulations, 2005.", Condition no. 2.2.5, p no 11.
- [2] Smith Nigel, "Motor as Generator for Micro-Hydro Power", Intermediate Technology Publications Ltd, London: P. no 23.
- [3] Krishna Gurung and Peter Freere, "Single Phase Output from 3 Phase self-Excited Induction Generators in Pico-Hydro Systems.", Destination Renewables – ANZSES 2003
- [4] H. Zainuddin, M. S. Yahaya, J. M. Lazi, M. F. M Basar and Z Ibrahim, "Design and Development of Pico-Hydro Generation System for Energy Storage Using Consuming Water Distributed to Houses.", International Scholarly and scientific Research and innovation Vol:3, No. 11, 2009.
- [5] Phillip Mahel And Nigel Smith, "Pico Hydro For Village Power A Practical Manual for Schemes up to 5 kW in Hilly Areas.", Edition 2.0, May 2001
- [6] Trunal K. Patel, R. P. Chawda, "Analysis Of 3 Phase Self Excited Induction Generator With Rectifier Load", International journal for technological research in engineering, Volume 2, Issue 5, January-2015
- [7] M. Kenneth J. Ayala, "The 8051 Microcontroller, Architecture, Programming and Applications", West Publishing Company.
- [8] R. C. Bansal, "Three-Phase Self Excited Induction Generators: An Overview", IEEE Transactions on Energy Conversion – July 2005