

Multi inputs and single output DC-DC Converter for Renewable Energy Resources

Sathish Kumar S, Vinoth Kumar S, Marutha Muthu M, Soundar A, Kumaresan A.

Department of Electrical and Electronics Engineering,
Gnanamani College of Technology, Namakkal-637018, India

Abstract— A dual DC input power supply for high output efficiency DC-DC converter is developed. The proposed converter can boost the varied voltages of different power supply in the sense of hybrid power supply to obtain a stable output dc voltage for the load demand. Based on the varied situations the operational mode of the proposed converter can be divided into two modes including a single power supply mode and dual power supply mode .In dual power supply state the input circuits are connected in series get added together with the designed pulse width modulation can greatly reduce the conduction loss of the switches. Single mode power supply will operate whenever it is capable to meet the load demand, when it cannot meet the load demand then dual power supply mode will operate

.The proposed high efficiency DC-DC converter with dual input power supply greatly reduces the conduction and switching losses in the system. This topology is developed to cope with the demerits of large size ,complex topology, and expensive cost in conventional converter with single power supply mode. MATLAB has been used to make the model and simulate the system and PI controller is used.

Keywords— DC-DC Converter, hybrid power supply

I.INTRODUCTION

One of the major concern of power generation sector is day to day increasing power demand

.Based on the current scenario all over the world especially India has lot of power shortage issues. The power developed from the fossil fuels are becoming so less as it degrade the environment and getting depleted day by day. So now days we are looking forward for the power generation from renewable energies like solar, wind, biomass, tidal etc which does not create any pollution to the environment. At present stand-alone solar PV system has been promoted around this global level on comparatively larger scale but this independent system cannot provide continuous energy as they are seasonal hence hybrid systems come into play. As the solar radiation varies throughout the day, the power generated also varies. Maximum power point trackers (MPPTs) play an important role because they maximize the power output for a set of conditions, and therefore maximize the efficiency generation from renewable energies like solar, wind, biomass, tidal etc which does not create any pollution to the environment. The use of renewable energy is helping the environment to reduce the global warming effect. In rural areas or remote areas where grid cant supply

the power there we can use this proposed dual input power source to meet the load demand.. The input impedance of the DC-DC converter is matched with the optimum impedance of PV panel. This method has good performance under MATLAB. R. J. Wai.,et.al [1] From this paper based on the environmental concern and the energy status, the developed electrical power may be insufficient to drive the load. To have the continuous power supply, we use hybrid power supply by using different kinds of sources. Those sources can be capacitor, fuel cell, rechargeable battery or best source renewable energies..

When the multi inputs are used in DC-DC converter simultaneous power will be delivered from all the sources which is not required at all the time, hence it increases complexity and cost of the system. As well the system design requires an enlarged storage equipment independently. Savita Nema,et.al[3] This paper helped in studying and modelling the PV panel using PV cell circuit model. Where the PV cell is been derived from the PN junction and it reflects the characteristics of the cell. In this paper we have come to know that how the conduction loss is been reduced across the switch, how the efficiency of the system is improved, Much more than the hard switching converter.

II.BLOCK DIAGRAM

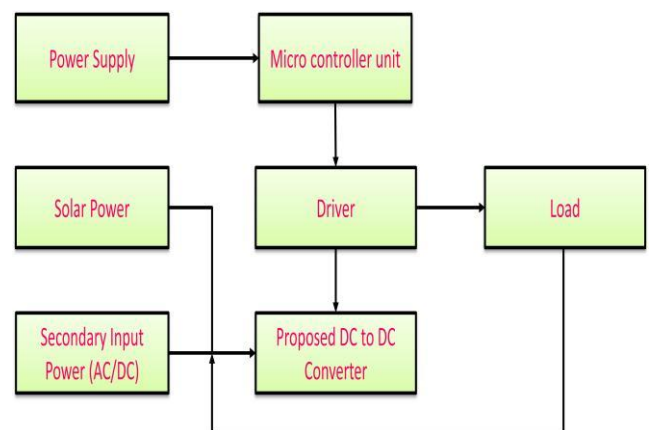

Figure: 1- block diagram.

This block diagram shows the way in which the dual input is fed to the boost converter. Solar and AC supply are the two input sources used here, these two sources are fed together to a boost converter to power the load based on load demand, so that the load demand is satisfied continuously.

Hence to know the changes in load demand a feedback loop i.e PI controller is used. This feedback loop from the load is taken and given to the secondary input that is to the AC supply, so that whenever the load demand is not satisfied by solar then the AC supply will be added up to the solar supply to meet the load demand.

III. CIRCUIT DIAGRAM

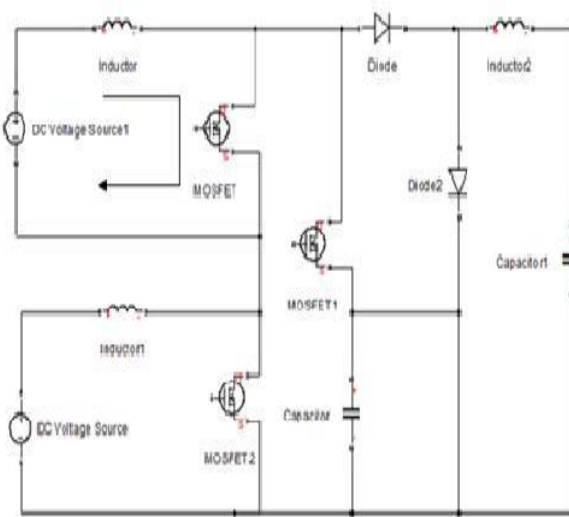

Figure-2: Equivalent Circuit of High Efficiency DC-DC Converter with Dual Input Power Sources

Single Mode Power supply

In this mode only one switch will be turned ON/OFF at a time to meet the load demand. The duty cycle for one switch will be 50% so that in the given 25kHz frequency 50% will be the on time & remaining off time.

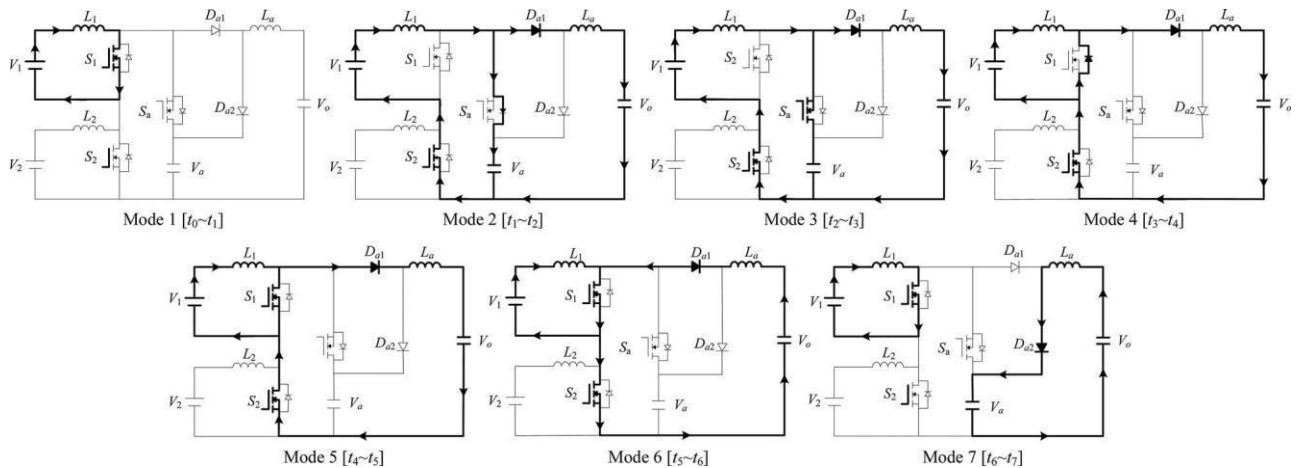

Fig-3; Topology modes in single mode power supply

Mode 1 $[t_0 - t_1]$: At t_0 , the auxiliary inductor current i_{La} returned to zero. The switch S_1 is continuously conducted and the auxiliary switch S_a is still turned OFF. The primary inductor L_1 is linearly charged by the primary input voltage V_1 . The auxiliary switch voltage v_{Sa} is equal to the auxiliary capacitor voltage V_a .

Mode 2 $[t_1 - t_2]$: At t_1 , the switch S_1 is turned OFF, the switch voltage v_{S1} is rising to the auxiliary capacitor voltage V_a , and the auxiliary switch voltage v_{Sa} is decreasing to zero. The body diode of the auxiliary switch S_a is conducted for receiving the primary inductor current i_{L1} to charge the auxiliary capacitor. Therefore, the switch current i_{Sa} is negative. Besides, the auxiliary inductor current linearly increases, and its slope is dependent on the auxiliary inductor voltage v_{La} , which is equal to $V_a - V_o$. Continuously, the primary auxiliary diode D_{a1} is conducted.

Mode 3 $[t_2 - t_3]$: At t_2 , the auxiliary switch S_a is turned ON with ZVS because the body diode has been already conducted for carrying the primary inductor current i_{L1} . After the auxiliary inductor current i_{La} increases to be larger than the primary inductor current i_{L1} , the auxiliary switch current i_{Sa} becomes positive. The discharging current from the auxiliary capacitor together with the primary inductor current i_{L1} releases the stored energy to the output voltage V_o .

Mode 4 $[t_3 - t_4]$: At t_3 , the auxiliary switch S_a is turned OFF. Because the auxiliary inductor current i_{La} is greater than the primary inductor current i_{L1} , the parasitic capacitor of the auxiliary switch S_a is charged by the auxiliary inductor current i_{La} so that the auxiliary switch voltage v_{Sa} rises. At the same time, the energy stored in the parasitic capacitor of the switch S_1 will release to the output voltage V_o via the inductor current i_{La} so that the switch voltage v_{S1} decreases.

The switch current i_{sa} falls down to zero and the switch voltage v_{sa} rises to the auxiliary capacitor voltage V_a . The body diode of the switch S_1 is conducted for carrying the differential current without strain. Besides, the auxiliary inductor voltage v_{La} is equal to $-V_o$, and the current i_{La}

linearly decreases. The energy stored in the auxiliary inductor L_a starts to discharge into the output voltage V_o as freewheeling.

Mode 5 [$t_4 - t_5$]: At t_4 , the switch S_1 is turned ON with ZVS upon the condition that the auxiliary inductor current i_{La} is still larger than the primary inductor current i_{L1} . The auxiliary inductor current i_{La} continuously decreases with the slope $-V_o/L_a$. After the current i_{La} is smaller than the primary inductor current i_{L1} , the switch current i_{S1} is positive.

Mode 6 [$t_5 - t_6$]: At t_5 , the auxiliary inductor current i_{La} is equal to zero. In this mode, the parasitic capacitor of the primary auxiliary diode D_{a1} is charged by the output voltage V_o with a small reverse-recovery current.

Mode 7 [$t_6 - t_7$]: At t_6 , the diode voltage $v_{D_{a1}}$ is rising to the output voltage V_o , the secondary auxiliary diode D_{a2} is conducted for receiving the auxiliary inductor current i_{La} to charge the auxiliary capacitor voltage V_a , and then the auxiliary inductor current i_{La} returns to zero. In the single power-supply state with the primary input power, the switch S_{P2} is always turned OFF and the switch S_2 is triggered all the while. It means that the switch S_2 works as a synchronous rectifier for avoiding the current to flow through its body diode and reducing the power losses in modes 2-7.

Dual Mode Power Supply

When the proposed converter is operated in the dual power supply state with two input power sources, it can be taken as a superposition process of the primary and secondary input circuits. In this state, the summation of duty cycles d_1 and d_2 should be greater than 1, i.e., each of duty cycles d_1 and d_2 is securely greater than 0.5. Moreover, the symbols d_{a1} and d_{a2} denote the first and the second duty cycles of the switch S_a , respectively. d_{dc1} and d_{dc2} present the first and the second duty cycles of the freewheeling times of the auxiliary inductor. In this mode both the switch will be conducting that is switch S_1 and S_2 and at the same time the auxiliary switch S_a will be turned off, as the auxiliary inductor current will return to zero, where as the inductor current I_1 and I_2 increases or charged by the input voltages v_1 and v_2 , the dual input voltage source will operate together and flows through the diode, as the auxiliary switch is switched off the current does not flow through the switch hence current across to it is zero.

The proposed converter is operated in this dual power supply state with dual input power sources, it is considered as superposition of both the input source that is been conducting, only because of this mode of operation the efficiency of the system is increased as the output voltage obtained is more stable. This mode is only highlighted in this project, and the entire concept used in this project is based on this dual power supply mode.

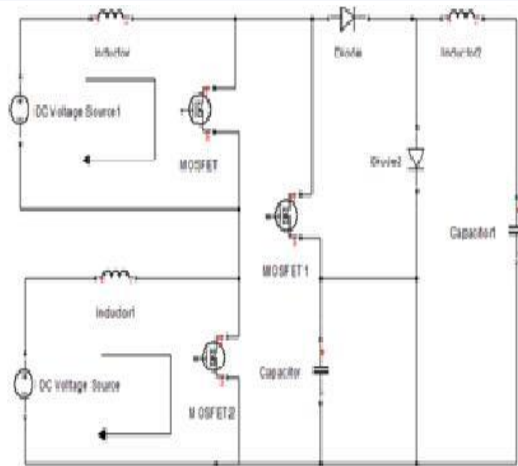

Fig-4. Equivalent Circuit of High Efficiency DC-DC Converter with Primary Input as Power Source

Mode 1 [$t_0 - t_1$]: At t_0 , the auxiliary inductor current i_{La} returned to zero. The switches S_1 and S_2 are continuously conducted. The auxiliary switch S_a is still turned OFF. The inductors L_1 and L_2 are linearly charged by the input voltages V_1 and V_2 , respectively.

Mode 2 [$t_1 - t_2$]: At t_1 , the switch S_2 is turned OFF, the switch voltage v_{S2} is rising to the auxiliary capacitor voltage V_a , and the auxiliary switch voltage v_{sa} is decreasing to zero. The body diode of the auxiliary switch S_a is conducted for receiving the secondary inductor current i_{L2} to charge the auxiliary capacitor.

Therefore, the switch current i_{sa} is negative. Besides, the auxiliary inductor current i_{La} linearly increases, and the slope is dependent on the auxiliary inductor voltage v_{La} ,

which is equal to $V_a - V_o$. Continuously, the primary auxiliary diode D_{a1} is conducted.

Mode 3 [$t_2 - t_3$]: At t_2 , the auxiliary switch S_a is turned ON with ZVS. After the auxiliary inductor current i_{La} increases to be larger than the secondary inductor current i_{L2} , the auxiliary switch current i_{sa} becomes positive. The discharging current from the auxiliary capacitor together with the secondary inductor current i_{L2} releases the stored energy to the output voltage V_o .

Mode 4 [$t_3 - t_4$]: At t_3 , the auxiliary switch S_a is turned OFF. Because the auxiliary inductor current i_{La} is greater than the secondary inductor current i_{L2} , the parasitic capacitor of the auxiliary switch S_a is charged by the auxiliary inductor current i_{La} , and the auxiliary switch voltage v_{sa} rises. At the same time, the energy stored in the parasitic capacitor of the switch S_2 will release to the output voltage V_o via the inductor current i_{La} , and the switch voltage v_{S2} decreases. The switch current i_{sa} falls down to zero and the switch voltage v_{sa} rises to the auxiliary capacitor voltage V_a . The body diode of the switch S_2 is conducted for carrying the differential current without strain. Besides, the auxiliary

inductor voltage v_{La} is equal to $-V_o$, and the current i_{La} linearly decreases. The energy stored in the auxiliary

inductor L_a starts to discharge into the output voltage V_o as freewheeling.

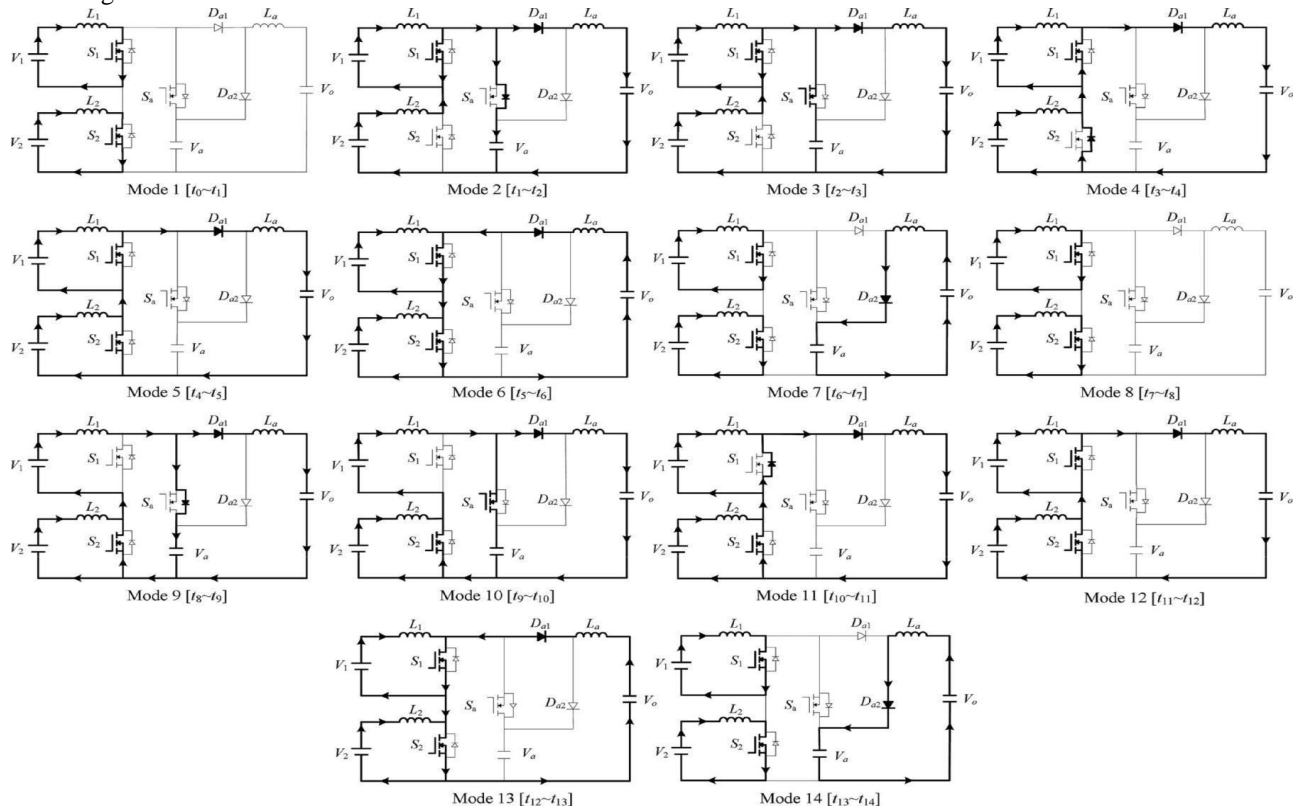

Fig-5. Topological modes in dual power-supply state.

Mode 5 [t4 –t5]: At t5 , the switch S2 is turned ON with ZVS upon the condition that the auxiliary inductor current i_{La} is still larger than the secondary inductor current i_{L2} . The auxiliary inductor current i_{La}

continuously decreases with the slope $-V_o/L_a$. After the current i_{La} is smaller than the secondary inductor current i_{L2} , the switch current i_{S2} is positive. By the same way, the switch current i_{S1} becomes positive as well as i_{S2} .

Mode 6 [t5 –t6]: At t5 , the auxiliary inductor current i_{La} is equal to zero. In this mode, the parasitic capacitor of the primary diode D_{a1} is charged by the output voltage V_o with a small reverse-recovery current.

Mode 7 [t6 –t7]: At t6 , the diode voltage v_{Da1} is rising to the output voltage V_o , the secondary auxiliary diode D_{a2} is conducted for receiving the auxiliary inductor current i_{La} to charge the auxiliary capacitor.

Mode 11 [t10–t11]: At t10, the auxiliary switch S_a is turned OFF. Because the auxiliary inductor current i_{La} is greater than the primary inductor current i_{L1} , the parasitic capacitor of the auxiliary switch S_a is charged by the auxiliary inductor current i_{La} . At the same time, the energy stored in the parasitic capacitor of the switch S_1 will release to the output voltage V_o via the inductor current i_{La} . The switch current i_{Sa} falls down to zero and the switch voltage v_{Sa} rises to the auxiliary

Mode 8 [t7 –t8]: At t7 , the auxiliary inductor current i_{La} returns to zero. The switches S_1 and S_2 are continuously conducted. Mode 8 is similar to mode 1.

Mode 9 [t8 –t9]: At t8 , the switch S_1 is turned OFF, the switch voltage v_{S1} is rising to the auxiliary capacitor voltage V_a , and the auxiliary switch voltage v_{Sa} is decreasing to zero. The body diode of the auxiliary switch S_a is conducted for carrying the primary inductor current i_{L1} to charge the auxiliary capacitor. The auxiliary inductor current i_{La} linearly increases with the slope $(V_a - V_o)/L_a$. Continuously, the primary auxiliary diode D_{a1} is conducted.

Mode 10 [t9 –t10]: At t9 , the auxiliary switch S_a is turned ON with ZVS. After the auxiliary inductor current i_{La} increases to be larger than the primary inductor current i_{L1} , the auxiliary switch current i_{Sa} becomes positive. The discharging current from the auxiliary capacitor together with the primary inductor current i_{L1} releases the stored energy to the output voltage V_o .

capacitor voltage V_a . Similar to mode 4, both the switches' currents i_{S1} and i_{S2} are negative. The energy stored in the auxiliary inductor L_a starts to discharge into the output voltage V_o as freewheeling.

Mode 12 [t11–t12]: At t11, the switch S_1 is turned ON with ZVS. The auxiliary inductor current i_{La} continuously decreases with the slope $-V_o/L_a$. After the current i_{La} is smaller than the primary inductor current

i_{L1} , the switch current i_{S1} is positive. By the same way, the switch current i_{S2} becomes positive as well as i_{S1} .

III. EXPERIMENTAL RESULTS

The proposed topology can be used to specific target applications for the high-voltage dc bus of an uninterruptible power supply or an inverter. The proposed converter can manipulate the high-efficiency power conversion with more than one input power source simultaneously to cope with the disadvantages of large size, complex topology, and expensive cost in conventional converter structure for individual power source.

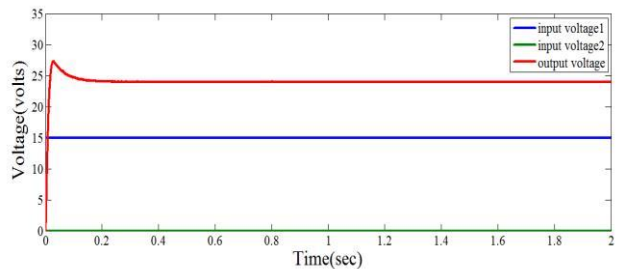
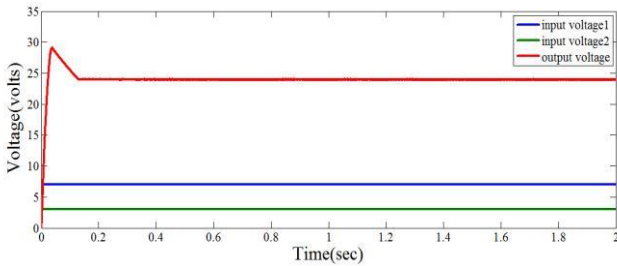

For an example of a hybrid PCS composed of two input power sources with an FC and a battery module, it has the following several merits: 1) it can manage the input power sources and improve system efficiency; 2) during the start of the system, the battery module powers the load to ensure that the FC cold starts easily; 3) when the load steps up, the battery module can provide the insufficient energy if the FC cannot respond quickly so

that the dynamic characteristics of the entire system

The minimum duty cycle d_{min} is designed to 0.55 slightly

higher than a half of 1, and the maximum duty cycle d_{max} is designed to 0.83 for avoiding the lack of freewheeling time of the auxiliary inductor operating in DCM. According to the relation between input voltages and duty cycles in (31), the two input voltages should be in the same level. Therefore, the voltage range of another power supply is chosen as 120–170V for mimicking a battery module taken as the secondary power source with a maximum power of 2.5 kW. The proposed converter can boost the varied voltages of different power sources in the sense of hybrid power supply to a stable output dc voltage for the load demand.

By considering the later inverter applications with 220 V_{ac}, the desired output dc voltage is set at 360 V and the maximum power of this converter proto-type is 5 kW in this study. Two magnetic contactors (S-P50T), manufactured by

can be improved; and 4) the battery module can provide the FC can be decreased and the total cost of the whole system can be reduced.

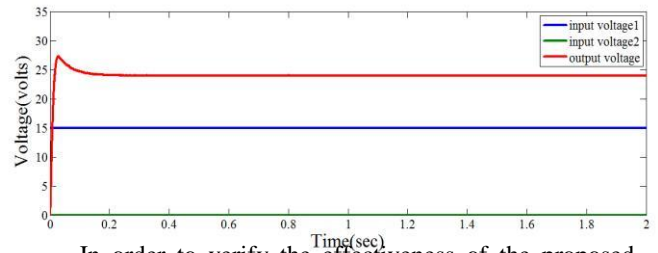

In order to verify the effectiveness of the proposed ZVS dual-input converter, the corresponding experimental results are provided in this section. A power supply is used to emulate an FC taken as the primary power source with a maximum power of 2.5 kW, and the input voltage range is 120–170 V. Note that the summation of duty cycles d_1 and d_2 should be greater than 1 for regular operation in the dual power-supply state. Thus, each of duty cycles d_1 and d_2 should be bounded from a minimum value d_{min} to a maximum value d_{max} .

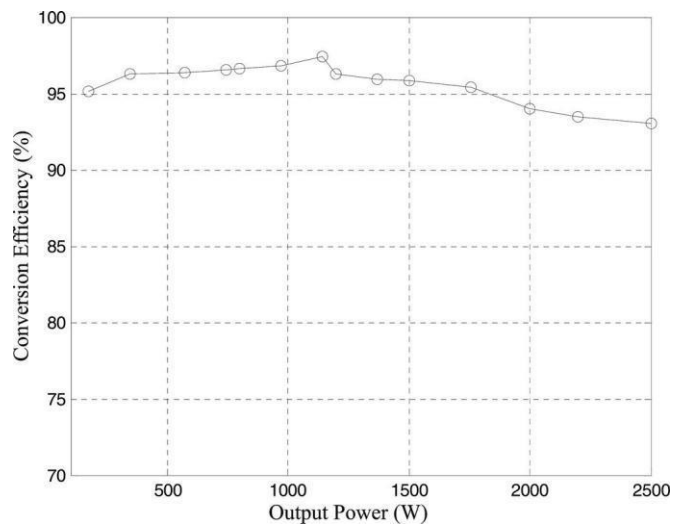

Shihlin Company, are used to switch the power supply situation between the single power-supply state and the dual power-supply state in the proposed converter.

CONCLUSION

A solar-AC hybrid generation system was proposed and implemented. This stand-alone hybrid generation system could effectively extract the maximum power from the solar energy sources. The proposed converter supplies continuous power to the load demand and greatly reduces the conduction and switching losses in the system. The simulation model of the proposed hybrid system is been developed using MATLAB/Simulink. Simulation results showed that the used PI controller could control the second switch properly so as to meet the load demand satisfactorily.

REFERENCES

- [1] T.Bhattacharya, T. V. S. Giri, K. Mathew, and L.Umanand, —Multiphase bidirectional fly back converter topology for hybrid electric vehicles,|| *IEEE Trans. Ind. Electron.*, vol. 56, no. 1, pp. 78–84, Jan. 2009
- [2] Kwasinski, A. —Identification of feasible topologies for multiple-input DC-DC converters,|| *IEEE Trans. Power Electron.*, vol. 24, no. 3, pp. 856–861, Mar. 2009.
- [3] Savita Nema, R.K.Nema, Gayatri —Matlab / simulink based study of photovoltaic cells / modules / array and their experimental verification|| *Volume 1, Issue 3, 2010 pp.487-500.*