

Modern Agricultural Management and Green House Monitoring System based on Wireless Communication

Choppara Manendra Babu¹,
¹ Pursuing M.Tech (VLSI&ES)
Newtons's Institute of Engineering,
Macherla, Andhra Pradesh, India

S Saidarao²
² Assistant Professor (ECE)
Newtons's Institute of Engineering,
Macherla, Andhra Pradesh, India

Abstract - The modern agriculture techniques plays a major role in rural areas where people also looking for an automated system which can monitor the crop status and can proceed with the required action. The system proposed in this paper describes about an implemented report of a remote monitoring and controlling station for Agriculture fields by using a Wireless communication established between the crop lands and monitoring station. In this paper, the system used 802.15 ZigBee as wireless communication carrier. The crop can be monitored in various aspects like environmental temperature, relative humidity in air, soil moisture in the land and the light condition on the plants, where the light will be more important concern for some kind crops. All the sensors can be interfaced to the monitoring station through wireless medium to exchange the data about the sensor readings. And the controlling task can be fulfilled in this paper by controlling the agriculture induction motors as well LED lighting strip for night time working if required.

Keywords — *Crop Monitoring; Agriculture; Humidity; Zigbee; Wireless; Sensors*

I. INTRODUCTION

The modern day's technology is influencing the field of rural agriculture as no one is exempted to the technology. The smart phone culture and rapid development in wireless communication technology, the people also looking for an automated method for agriculture forming. The rural areas have the problem with power supply interruptions where they causes problem for the water supply to the plants. Due to industrial development, the rural areas getting polluted because of industrial waste is flowing towards agriculture fields, so that the plants can get harm with the chemical dump. And also due to usage of chemical fertilizers and hybrid forming methods, the soil gets week by losing its minerals and strength. The mineral resources and water resources are getting decreased due to advanced methods of cultivation using by the human for faster results from the crops.

The system is implemented to make the efficient utilization of resources and to save it for the future usage. Due to following the advanced methods of agriculture and chemical fertilizers instead of natural resources available in land, the crop will also give the result as less strengthen crop like hybrid fruits and vegetables. So, by avoiding the wastage of resources as well by using the enough resources in a required amount, we can avoid the shortage of natural resources.

Agriculture methods are enhanced in this paper by interfacing a wireless sensor network to it. The wireless sensor network consists of the electronic sensor modules which can give the digital output by detecting a environmental parameter at the fields. The controlling actions for switching the motor is also can be done by the ZigBee connected at the monitoring station. The system described in this paper is fully automated agriculture monitoring system where we can observe the status of the crop and can control the water supply to the crop from the remote station.

II. LITERATURE SURVEY

The research has done on various wireless communication technologies to propose this paper. As in the paper "Wireless based load control and power monitoring system" proposed by Makwana, R. ; Dept. of Electron. & Telecommun., Sardar Patel Inst. of Technol., Mumbai, India, the wireless technologies will be chosen by considering the required power consumption and most importantly the communication range supported in that particular technology. In that paper they described about the ZigBee and Bluetooth technologies as wireless interface for load switching. In this paper, we adopted the ZigBee technology for switching the agriculture motors. The study was continued on establishing wireless sensor networks. The sensors usage is according to the requirement of the user and what the user want to monitor in the environment in their fields. The data from the sensor network should be exchanged to the remote monitoring station to give the update about the field conditions.

As described in the paper, "Platform of Wireless Sensor Networks" proposed by Jin-Shyan Lee ; Ind. Technol. Res. Inst. (ITRI), Hsinchu, the wireless sensor network is established by using ZigBee wireless interface to exchange the physical and environmental parameters in an industry and the network is having low data rate, low speed and low power consumption. We adopted the technology for monitoring the environmental parameters in a field in this proposed system.

III. SYSTEM ARCHITECTURE

The proposed system in this paper consisting of temperature sensor, humidity sensor, soil moisture sensor and light dependent resistor to monitor the parameters and a ZigBee transceiver is interfaced with the microcontroller to exchange the data about the sensor readings. The heart of the

system is microcontroller, here we used LPC2148 to process the sensor operations.

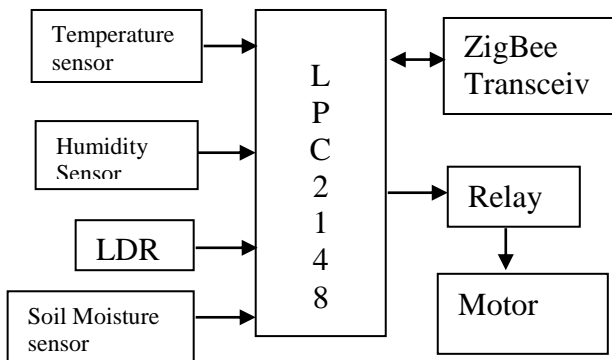

Fig1: Sensor Section

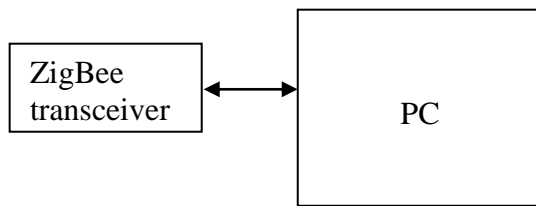

Fig2: Monitoring Section

The above figures shows the block diagram of both sensor section and monitoring section respectively which exhibits the major parts of the proposed system.

The LPC2148 is a 32-bit microcontroller which is having ARM7 TDMI processor in it. It will gives us the wide range of features to implement a high level embedded applications. The LPC2148 is having many inbuilt features in it which include on board communication protocols like SPI, I2C and UART. As well it is having the Analogue to Digital converter in it, which will be most useful in our system implementation where we need to get the output from the analogue sensors.

The communication interface we used in this system is ZigBee (IEEE 801.15). Due to our application requirement range, we intended to prefer the ZigBee communication because of it is less expensive also. The communication range is also good enough to monitor the field from the form house. The data will be updated through ZigBee path about the environmental conditions obtained from the sensors. The ZigBee standard works on the frequency band of 2.4GHz which is one of the unlicensed band of frequencies provided by ISM. The protocol radio in the hardware concern is also implemented carefully and optimized to get less expensive standard and the hardware contains some analog circuit stages but possibly optimized with digital circuits. The data rate of the ZigBee standard is in various types based on the frequency band using. It will gives us 250kbps per channel with 2.4GHz frequency band, if 915MHz band used, it will give 40kbps per channel and 868MHz band gives 20kbps per channel.

The sensors used in this system includes temperature sensor, humidity sensor, soil moisture sensor and light sensor.

Temperature sensor we used is DS1621, which works with I2C protocol interface and it gives an accurate temperature reading in digital form of data directly. Due to its I2C interface, the hardware complexity will be reduced to connect it with

microcontroller and the data accessing from the sensor IC will be accurate.

The soil moisture sensor will monitor the volumetric content of water in the soil based on various parameters like dielectric constant, electrical resistance and temperature. It gives the analogue voltage signal according to the moisture level. The soil moisture sensor is very useful in modern irrigation methods to reduce the human efforts to monitor the water content in the field continuously.

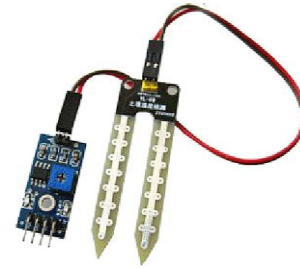

Fig3: Soil Moisture Sensor

The humidity sensor will obtain the relative humidity in the air. The humidity factor is very important weather parameter. The high humidity in the sir will not be comfortable for human being as well it affects the biological and physical parameters which will also harmful for some industrial processes and manufacturing units. It gives the analogue voltage signal according the relative humidity contained in the air.

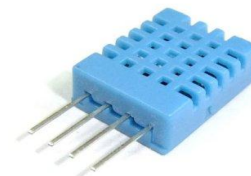

Fig4: Humidity sensor

The light sensor is nothing but LDR, which varies the resistance based on the light illumination. The light is also important in some cases where the plants can feed themselves from the sun light only. The LDR (Light Dependent Resistor) gives the resistance based on the light intensity in a inversely proportional relationship. Monitoring the light intensity is also useful for the agriculture systems for providing the external light to work in the evening times when sun light fails.

Additionally, the system is also deal with the control section of agriculture fields which involves the ON/OFF of the motor to pump the water. The water pumping motor can be interfaced to the microcontroller through a relay to switch it ON/OFF. The user has to send a control keyword from the monitoring station, then the controller receives it and performs the ON/OFF based on the command.

IV. SOFTWARE IMPLEMENTATION

The software implementation part of this system involves various tools as follows

1. Keil uVision
2. Flash Magic

The entire software implementation was done in C language. For developing any kind of application in any programming language, we need an IDE which will provide a complete programming environment for the particular high level programming language.

Here in our system, we used Keil uVision, which is an IDE for developing C/C++ applications. It will provide the completed development environment with all the required tools like compiler, debugger, and simulator in it.

The Flash magic is the tool, we used to deploy the written code into the microcontroller. As the microcontroller can only understand machine level language, we need to convert the code written in high level language into machine level language and have to deploy it into microcontroller's ROM.

To communicate with the microcontroller section through ZigBee, we need an interfacing terminal which can receive and display the data from ZigBee transceiver. And the terminal application is also available in Flash magic.

V. WORKING METHODOLOGY

The implemented system of greenhouse monitoring consists of two section, monitoring section and controlling section. The monitoring section consists of a personal computer installed with a terminal application and connected with a ZigBee transceiver. The controlling section is having one microcontroller with all the sensors. Among all the sensors, the temperature sensor and soil moisture sensor will be monitored continuously and sends the information to the monitoring computer.

Whenever the humidity is increased higher than the required level, the sensor will gives the information and updates it to the monitoring station. Similarly, the light sensor will monitor the light intensity and if gets very low light intensity in the greenhouse, then it automatically switches the LED lights ON. The usage of LED lights makes less electricity consumption. In the same way, the temperature sensor will monitor the temperature in the greenhouse and based on that, we can provide the heating or cooling solution from the given information. The readings from the soil moisture sensor will indicates the volumetric water content and if gets very low, then we can make a decision about pumping the water immediately based on the crop growing in the green house. Some crops requires less water and some deserver more.

The motor and cooling fan are externally connected to the microcontroller through a driver circuit. Whenever the user observed that the soil moisture getting low, they can perform required action based on the crop, if the crop needs more water, then the user can able switch the motor ON likewise when the soil moisture is high and the motor is in ON condition, then the user can switch it OFF by sending a command. The same thing can be done to the cooling fan also based on the temperature in the greenhouse environment.

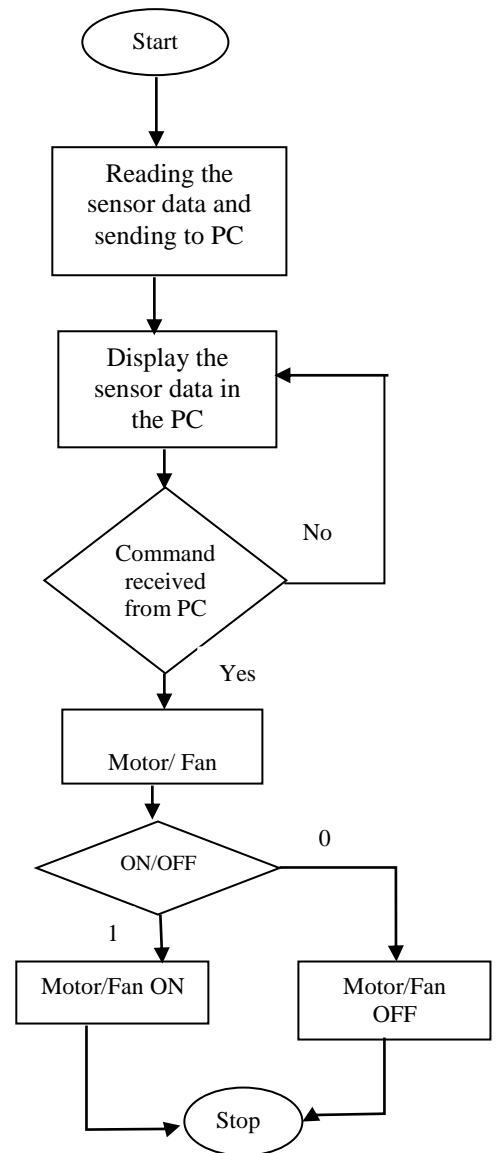

Fig5: Flow Chart

The above figure shows the working flow of the implemented system.

VI. CONCLUSIONS

The designed system of agriculture monitoring and green house maintenance is an efficient solution for field monitoring with various sensor to obtain various weather conditions. The controlling of agriculture motor makes it a complete system for monitoring and controlling.

REFERENCES

- [1] R. Makwana, J. Baviskar, N. Panchal and D. Karia, "Wireless Based Load Control and Power Monitoring System", *Proceedings of International Conference on Energy Efficient Technologies for Sustainability (ICEETS),Nagarcoil,India*, pp.1207-1211, April 2013.
- [2] S. Palanisamy, S. Senthil Kumar, and J. Lakshmi Narayanan, "Secured Wireless Communication for Industrial Automation and Control", *Proceedings of 3rd International Conference on Electronics Computer Technology (ICECT)*, vol. 5, pp. 168-171, April 2011.
- [3] J. S. Lee, Y. W. Su, and C. C. Shen, "A Comparative Study of Wireless Protocols: Bluetooth, UWB, ZigBee, and Wi-Fi", *Proceedings of the 33rd Annual Conference of the IEEE Industrial Electronics Society (IECON)*, pp. 46-51, November 2007.

- [4] R Aquino-Santos and A Gonzalez-Potes, "Monitoring Physical Variables in Greenhouse Environments", Available at :www.istec.org
- [5] "ZigBee Specification", ZigBee Alliance, ZigBee Document 053474r06, Version 1.0, December 2004.
- [6] J. S. Lee and Y. C. Huang, "ITRI ZBnode: A ZigBee/IEEE 802.15.4 Platform for Wireless Sensor Networks", *Proceedings of IEEE International Conference on Systems, MAN and Cybernetics, Taipei, Taiwan*, vol. 2, pp. 1462-1467, October 2006
- [7] "ZigBee-Setting Standards for Energy-Efficient Control Networks", *White Paper by Schneider Electric Industries SAS*, No. P40110601EN, June 2011.
- [8] E. Ferro and F. Potorti, "Bluetooth and Wi-Fi wireless protocols: a survey and a comparison", *Wireless Communications, IEEE*, vol. 12, no. 1, pp. 12-26, February 2005.
- [9] J. S. Lee, "Performance Evaluation of IEEE 802.15.4 for Low-Rate Wireless Personal Area Networks", *IEEE Transactions on Consumer Electronics*, vol. 52, no. 3, pp. 742-749, August 2006.
- [10] V.K.Garg, "Wireless Communication and Networking", ISBN: 978-81-312-1889-1, pp. 691-697.
- [11] M. Colotta and V.M.Salerno, "A Real Time Network Based On IEEE 802.15.4/ZigBee To Control Home Automation Environment ", Available at: <http://guap.ru/guap/nids/pdf2010/collotta.pdf>
- [12] "XBee Series 2 OEM RF Modules Product Manual", *Digi International, Inc.*, June 2007.
- [13] "X-CTU Configuration and Test Utility Software User Guide", *Digi International, Inc.*, August 2008.
- [14] Datasheet Available at: <http://www.atmel.com/Images/doc8161.pdf>
- [15] Datasheet Available at: <http://yourduino.com/docs/Photoresistor-5516-datasheet.pdf>
- [16] Z. Quan, Y. Xiang-long, Z. Yi-ming and W. Li-ren, "A wireless solution for greenhouse monitoring and control system based on ZigBee technology", *Journal of Zhejiang University 2007*, ISSN 1673-565X

AUTHOR DETAILS

Author 1:



NAME: CHOPPARA MANENDRA BABU, pursuing M.Tech (VLSI&ES) from Newton's Institute of Engineering (NEWT), Macherla, Andhra Pradesh – 522426

Author 2:



Name: S.SAIDARAO

Mr. S.SAIDARAO was born Guntur, AP, on November 02 1987. He graduated from the Jawaharlal Nehru Technological University, Hyderabad. Presently He is working as a Asst Prof in Newton's Institute of Engineering, Macherla. So far he is having 7 Years of Teaching Experience in various reputed engineering colleges. His special fields of interest included Microprocessors and microcontrollers, Embedded Systems, Digital Signal Processing & communication Systems. working as an Assistant Professor (ECE) from Newton's Institute of Engineering (NEWT), Macherla, Andhra Pradesh - 522426