

Mining Environment Monitoring System using Li-Fi

Rajesh H S, Punith D Gowda, Pallavi N S, Shilpa R, Kavitha B C
Dept. of ECE, BGSIT,
Karnataka, India,

Abstract:- In any Mine, there are many risk factors. In order to safe guard the people working inside the mine its environmental parameters are monitored. The hardware consisted of electronic circuitry where a microcontroller is the principal processing unit. A graphical user interface is also implemented. A number of qualification tests are carried out. The temperature, humidity, airflow and noise sensor measurements have an accuracy of 89.01%, 98.55%, 90.5%, 89.53% and a resolution of 0.105°C, 0.12% RH, 0.05m/s and 0.23 dB SPL respectively. In addition gas and dust sensors met the specification; however, the accuracy could be improved. Since the consequences of mining cannot be avoided, its effect can be predicated in order for safety precautions.. The monitored parameters can be send using IOT modem and IBEACON Devices.

Keywords: NIOSH (National Institute for Occupational Safety and Health), IOT (Internet Of Things), mining industry, sensor systems, temperature measurement, humidity measurement, airflow measurement, noise sensor measurement, wireless

I.INTRODUCTION

Mining as defined by the Oxford Dictionary is the process or industry of obtaining coal or other minerals from a mine. The activities carried out in order to obtain these minerals have a dangerous element to them. The average mine worker is exposed to the harsh underground environment which can sometimes incur an Injury or cause loss of life. These conditions are difficult to monitor without placing someone's life at risk. The older methods of mine condition monitoring involved using a person to go down and report back. This method is however dangerous as the person who is monitoring a specific hazard could be harmed by that very same hazard [1]. This type of first hand monitoring is invasive. There is an existence of specific systems or schemes which are put into Place for these hazardous environments in order to protect the worker from harm. The higher level term for these systems/schemes is the Occupational Health and Safety. The International Organization of Standardization or ISO have a standard namely the ISO 45001. This standard aims to reduce the liability of occupational injuries and diseases not only to Benefit the workers but also the economy upon which this work builds [2]. These accidents can lead to losses due to early retirements and increased insurance premiums for the mine. In order to save the mine workers from environmental hazardous, we have to communicate with mine workers in the underground section the data must first be measured through the use of environmental parameters. The environmental Parameters like temperature, gas, water level, vibration sensors are used. These sensors measure analog voltage values based upon specific ambient characteristics. The applications

of sensors are vast in that there are a large number of characteristics which can be measured. The utility of sensors is apparent in applications where the characteristic measurement is required in real-time [7]. The characteristics measured in this project include: (i) temperature, (ii) air-flow, (iii) humidity, (iv) noise, (v) dust and (vi) gas concentration. Each of these characteristics can be solely or collectively responsible for incurring a risk to a mine worker.

The growth of mineral resources as an emerging and existing economic sector, the increase in mining activity has become essential to this sector and to the economies these markets are built on. The practice of mining can be dangerous [8] and unsafe. The previous statement is only true for mines that do not monitor conditions inside the mine. There exists a relationship between three entities namely a hazard, latent danger and an accident which find their existence due to this dangerous and potentially unsafe practice. This relationship is illustrated in figure 1 below.

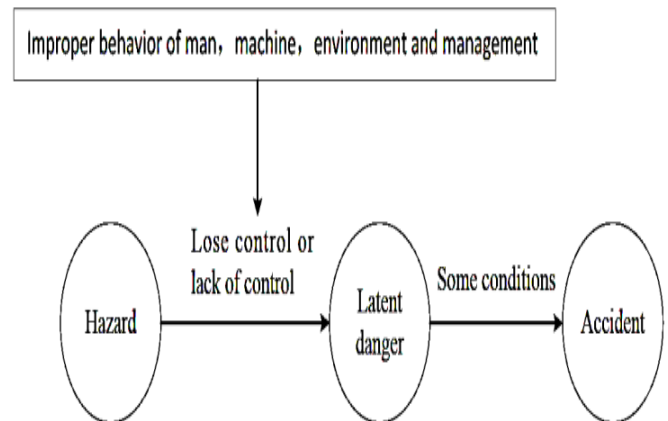

Fig 1: The relationship between hazard, latent and accident

The system was completely designed from first principles; this includes the sensor hardware, device hardware, PCB layout, software algorithms, as well as a graphical user interface. The proposed system designed examines and implements certain functionality that solves the above-mentioned short comings or limitations in real-time mining environment monitoring [9]. The system allows for monitoring of multiple different zones inside the mine, the protection of mine workers from excessive noise levels and the storage of measurement data for purposes of reference. Background on current methods of obtaining and processing the mentioned ambient

characteristics has been discussed. Next the system overview from a high level perspective will be discussed. The results presented from this system show its validity. These results are then used as the basis for the discussion and conclusion.

II. BLOCK DIAGRAM

Block diagram is the heart of our project, it consists of two sections are transmitter and receiver section. The monitored parameters value are transmitted to server means IOT through Wireless (Wi-Fi). The user can see the result at anywhere and control harm to the mining people.

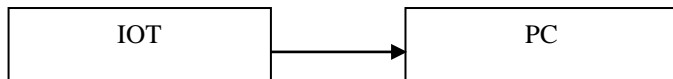

Fig 2: Receiving Section

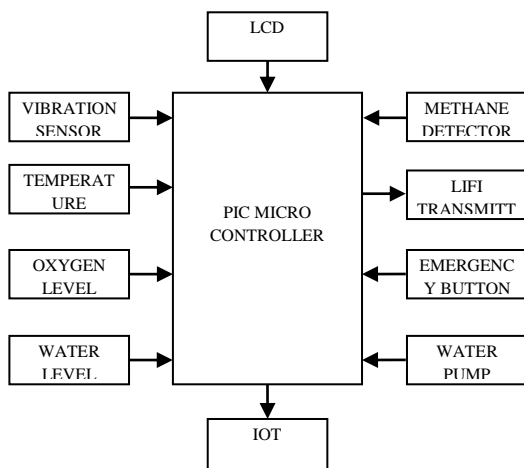

Fig 3: Transmitting Section

III. LITERATURE SURVEY

In underground mining, ventilation systems are crucial to supply sufficient oxygen, maintaining non-explosive and non-toxic atmospheres and operating an efficient mine. Mine ventilation system can help in eliminating high risk atmosphere. Primitive techniques to monitor the mining atmosphere can be traced back to the use of canaries and other animals to alert miners, when the atmosphere becomes toxic. Integrating ventilation monitoring system enables mine to intelligently make ventilation changes based on the extensive data, the monitoring system provides. Unexpected changes in the ventilation system are noticed by the monitoring arrangement, allowing prompt action to be considered. New and developing communication and tracking systems can be utilized to monitor mines more efficiently and relay the data to the surface. Building a safety system to monitor the ambient characteristics of the mining environment. Remote monitoring of the health conditions of miners can better aid search-and-rescue efforts after accidents. To develop a secure sensor network by interconnecting attestation between surrounding sensor nodes. In this paper, the hazard theory, system security and risk analysis theory have been used to screen the evaluation indexes. Analytic hierarchy process and mean

square error method were applied to determine the weight of each index and establish a comprehensive evaluation system. Providing low data rate for short coverage and long battery life using ZigBee module. Monitoring data in coal mine is essentially data stream with the change of environment, coal mine monitoring data stream implied concept drifts. Coal mine safety evaluation can be seen as concept drifting data streams classification. Large lead-acid batteries are predominantly used throughout the mining industry to power haulage, utility and personnel-carrier vehicles. Without proper operation and maintenance, the use of these batteries can introduce mechanical and electrical hazards, particularly in the confined, and potentially dangerous, environment of an underground coal mine.

Existing System

- Wireless protocol like ZigBee is used for communication.
- Missing person are found using PIR sensor.
- In some mines like coal mine, at some temperature the coal starts to burn so a temperature sensor is used.

Proposed System

- Due to mining, there may be many natural consequences like poisonous gas or earthquake. These factors are monitored.
- Immediate alert system is implied to protect workers life when they are in danger.

IV. SYSTEM DESIGN

Hardware Components

- PIC16F877A
- IOT
- PC
- Vibration Sensor
- Temperature Sensor
- Gas Sensor
- Water level sensor
- Buzzer
- LCD
- Water pump
- LI-FI (LED)

(a) PIC Controller (PIC16F877A)

PIC (Peripheral Interface Controller) is a family of microcontroller made by Microchip Technology, derived from the PIC1650 originally developed by General Instrument's Microelectronics Division. The name PIC initially referred to Peripheral Interface Controller, and then it was corrected as Programmable Intelligent Computer. The first parts of the family were available in 1976; by 2013 the company had shipped more than twelve billion individual parts, used in a wide variety of embedded systems.

Early models of PIC had read-only memory (ROM) or field-programmable EPROM for program storage, some with provision for erasing memory. All current models use flash memory for program storage, and newer models allow the PIC to reprogram itself. Program memory and data memory are

separated. Data memory is 8-bit, 16-bit, and, in latest models, 32-bit wide. Program instructions vary in bit-count by family of PIC, and may be 12, 14, 16, or 24 bits long. The instruction set also varies by model, with more powerful chips adding instructions for digital signal processing functions

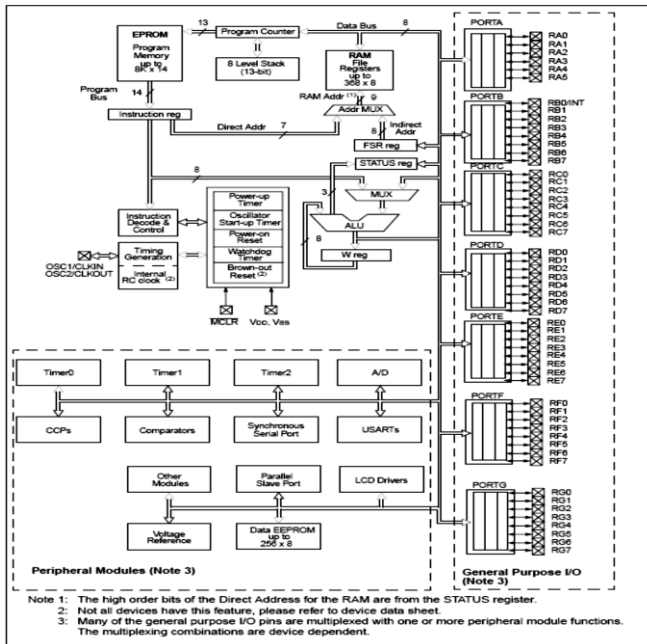

Fig 4: Basic Block Diagram Of PIC Microcontroller

(b) Temperature Sensor

Temperature is the most-measured process variable in industrial automation. Most commonly, a temperature sensor is used to convert temperature value to an electrical value. Temperature Sensors are the key to read temperatures correctly and to control temperature in industrial applications. A large distinction can be made between temperature sensor types. Sensors differ a lot in properties such as contact-way, temperature range, calibrating method and sensing element. The temperature sensors contain a sensing element enclosed in housings of plastic or metal. With the help of conditioning circuits, the sensor will reflect the change of environmental temperature.

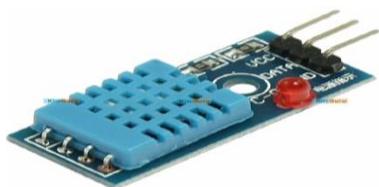

Fig 5: Temperature Sensor

(c) Buzzer

A buzzer or beeper is a signalling device, The word "buzzer" comes from the rasping noise that buzzers made when they were electromechanical devices, operated from stepped-down AC line voltage at 50 or 60 cycles. Other sounds commonly used to indicate that a button has been pressed are a ring or a beep.



Fig 6: Buzzer

(d) Gas Sensor

In deep cave mining, some poisonous gases like methane, carbon monoxide, sulphur dioxide etc emit from the cave walls. In order to, detect these poisonous gas, gas sensors are used.

Features

- * High sensitivity to LPG, natural gas , town gas
- * Small sensitivity to alcohol, smoke.
- * Fast response.
- * Stable and long life
- * Simple drive circuit

Application

They are used in gas leakage detecting equipments in family and industry, are suitable for detecting of LPG, natural gas , town gas, avoid the noise of alcohol and cooking fumes and cigarette smoke.

OXYGEN LEVEL: the oxygen level in the mine should be not more than a limit. This is because if the oxygen level is too high the flammable materials will catch fire. Also if the oxygen level is too low the workers will be affected.



Fig 7: Gas Sensor

(e) Water Level Sensor

A float switch is a device used to sense the level of liquid within a tank. When the float ball rises or falls with the liquid to the level of the switch, The magnetic force of magnet which inside of the float ball will cause the reed switch to turn ON. When the float ball move away from the reed switch, the reed switch will turn OFF.

Specifications:

- Normally Open Type (Yellow Wire) and Normally Close Type (Blue Wire)
- Corrosion Free Material
- Advance Magnetic Technology
- Cable Length : 2 meter
- Max Switch Current : 500 mA (DC), Max Switch Watt : 10W



Fig 8: Water level Sensor

(f) Light Emitting Diodes (LED)

Function

LEDs emit light when an electric current passes through them.

Connecting and soldering

LEDs must be connected the correct way round, the diagram may be labelled **a** or + for anode and **k** or - for cathode (yes, it really is k, not c, for cathode!). The cathode is the short lead and there may be a slight flat on the body of round LEDs. If you can see inside the LED the cathode is the larger electrode (but this is not an official identification method). LEDs can be damaged by heat when soldering, but the risk is small unless you are very slow. No special precautions are needed for soldering most LEDs.

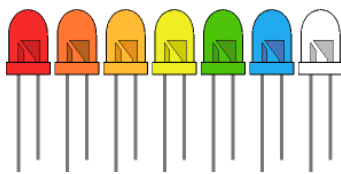

Fig 9: Different forms of LED

Testing an LED:

Never connect an LED directly to a battery or power supply! It will be destroyed almost instantly because too much current will pass through and burn it out.

LEDs must have a resistor in series to limit the current to a safe value, for quick testing purposes a 1kΩ resistor is suitable for most LEDs if your supply voltage is 12V or less. Remember to connect the LED the correct way round! LEDs are available in red, orange, amber, yellow, green, blue and white. Blue and white LEDs are much more expensive than the other colours.

The colour of an LED is determined by the semiconductor material, not by the colouring of the 'package' (the plastic body). LEDs of all colours are available in uncoloured packages which may be diffused (milky) or clear (often described as 'water clear'). The coloured packages are also available as diffused (the standard type) or transparent.

(g) Water Pump

The water that rises from the ground level is pumped out of the mine area using the water pump.

(h) IOT Modem

The sensor values like temperature, oxygen level, poisonous gas detection etc are monitored and proper control action are taken through IOT modem from control room.

(i) Vibration Sensor

Due to continuous digging, the earth template gets disturbed, so there may be a slight shake in the earth or it could even lead to earthquake. Hence vibration level is determined using the vibration sensor and proper safety alerts are given to the worker.

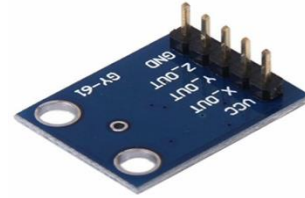

Fig 10: Vibration Sensor

(j) Li-Fi

Li-Fi is a technology for wireless communication between devices using light to transmit data. In its present state only LED lamps can be used for the transmission of visible light.^[1] The term was first introduced by Harald Haas during a 2011 TED Global talk in Edinburgh.^[2] In technical terms, Li-Fi is a visible light communications system that is capable of transmitting data at high speeds over the visible light spectrum, ultraviolet and infrared radiation. In terms of its end use the technology is similar to Wi-Fi. The key technical difference is that Wi-Fi uses radio frequency to transmit data. Using light to transmit data allows Li-Fi to offer several advantages like working across higher bandwidth, working in areas susceptible to electromagnetic interference (e.g. aircraft cabins, hospitals) and offering higher transmission speeds. The technology is actively being developed by several organisations across the globe.

(h) LCD

There are many display devices used by the hobbyists. LCD displays are one of the most sophisticated display devices used by them. Once you learn how to interface it, it will be the easiest and very reliable output device used by you! More, for micro controller based project, not every time any debugger can be used. So LCD displays can be used to test the outputs. Obviously, for last possibility, you need to know how to use this stuff pretty well.

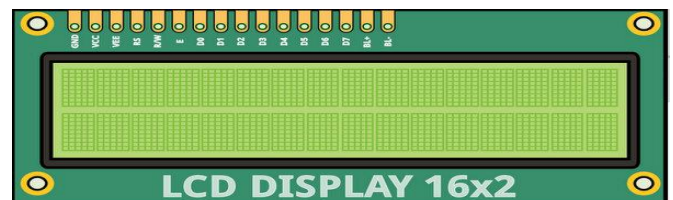

Fig 11: LCD Display

Hitachi has set up a mile stone by its LCD controller IC. All the LCD displays use the same, or any one of the IC s based upon the architecture introduced by Hitachi. Ok, one minute, all I'm talking about is the character LCD display and not Graphical LCD Display. Most of the LCD Displays available in the market are 16X2 (That means, the LCD displays are capable of displaying 2 lines each having 16 Characters a),

20X4 LCD Displays (4 lines, 20 characters). It has 14 pins. It uses 8lines for parallel data plus 3 control signals, 2 connections to power, one more for contrast adjustment and two connections for LED back light.

V. SYSTEM ARCHITECTURE

This architecture will be fixed with some sensors that are temperature sensor, gas sensor, tilt sensor, humidity sensor and obstacle sensor all these sensors are interfaced with PIC16F877A microcontroller and intern PIC controller connected to LCD display to display the parameter values. PIC controller is connected to transmitter Wi-Fi module in order to transmit the information if any parameter variation in the mining area to receiver Wi-Fi module located in ground PC.

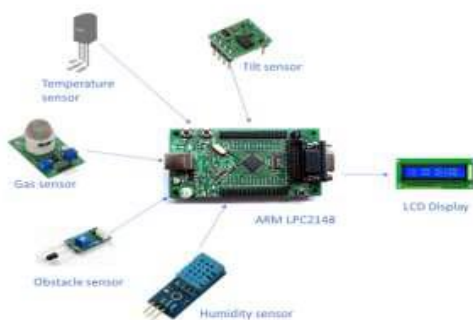

Fig 12: System Architecture

Concentration Node

The concentration node consists of ground PC which is wirelessly connected to the receiver Wi-Fi module in order to collect the information stored in the cloud through IoT and provide safety measures for the mine workers when hazardous conditions occurs in the mining area. This section will give information to the nearby hospitals in order to save the life of mine workers when hazardous conditions occurs in mining area.

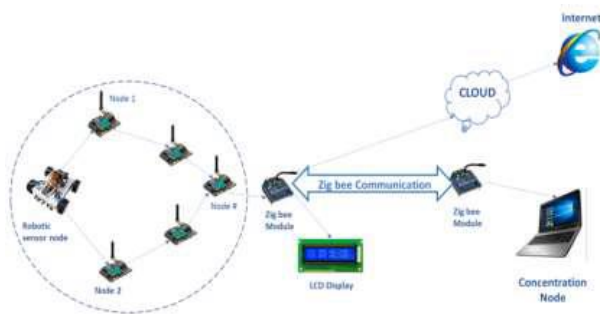

Fig 13: Concentration Node

VI. SOFTWARE REQUIREMENTS

Embedded C

Embedded C Programming is the soul of the processor functioning inside each and every embedded system we come across in our daily life, such as mobile phone, washing machine, and digital camera. Each processor is associated with embedded software. The first and foremost thing is the embedded software that decides functioning of the embedded

system. Embedded C language is most frequently used to program the microcontroller.

Earlier, many embedded applications were developed using assembly level programming. However, they did not provide portability. This disadvantage was overcome by the advent of various high level languages like C, Pascal, and COBOL. However, it was the C language that got extensive acceptance for embedded systems, and it continues to do so. The C code written is more reliable, scalable, and portable; and in fact, much easier to understand.

Salient Features:

- C language is a software designed with different keywords, data types, variables, constants, etc.
- Embedded C is a generic term given to a programming language written in C, which is associated with a particular hardware architecture.
- Embedded C is an extension to the C language with some additional header files. These header files may change from controller to controller.
- The microcontroller 8051 #include<reg51.h> is used.

VII. ADVANTAGES AND DISADVANTAGES

Advantages:

- Natural consequences are detected and proper control actions are taken.
- Water pump system enables a secured and also easy way of mining process.

Disadvantages:

- Poisonous gases presence is not monitored.
- Sudden change of environment factors is not predicted.

VIII. RESULT AND FUTURE WORK

Result:

In any Mine, there are many risk factors. In order to safe guard the people working inside the mine its environmental parameters are monitored. In earlier days if any harmful effects are occurred send a person and get report back. In our project we can avoid this risk by monitoring environment parameters. We can see the result at anywhere through IOT that what is happening in the mining. Li-Fi technology is wireless communication and eco friendly to nature. We can get the information with the help of LED (i.e. light). Then send information to them to come out from there. In our project PIC controller is heart of our project, it controls all parameters

Future Work:

In our project we can just avoid harm to the mining people, but we can't bring them to the up. If a person affected by parameters by high temperature, more water level or harmful gases. We can just give the information that what's happening there, but we can't back. So in future with this module add one robot to that, this robot helps to come out them.

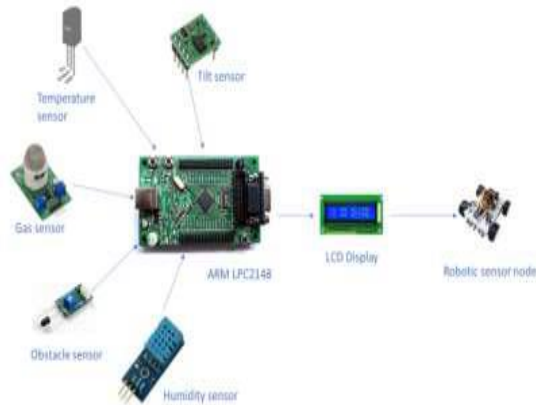

Fig 14: Robotic section

IX. CONCLUSION

The application of wireless sensor network will improve the safety of coal mine. The wireless is more flexible and can avoid of rewiring and also it will greatly improve the performance and efficiency of data transmission of the coal mine safety system. In this application, as we are storing the values of the parameters in the PC, the stored values can be used to detect the hazards before they happen. As we are giving the information to the personnel regarding the measures to be taken in case of a hazard, it will be useful for them to save their life before any one comes and help them to come out of the mine.

REFERENCES

- [1] VALDO HENRIQUES AND REZA ALEKIAN,"Mine safety data system using wireless sensor network", IEEE Trans. Ind. Appl., of publication June 16, 2016
- [2] Muzaffer Kanaan and Eda Simsek,"On the use of zigbee technology for coal mine safety",IEEE Trans Ind.,published in 2016 24th signal processing and communication application conference.
- [3] Gang sun; Zhongxin Wang; Jia Zhao; Hao Wang; Huaping Zhou; Kelei sun,"A coal mine safety evaluation method based on concept drifting data stream classification",2016 12th International conference on National Computation,Fuzzy Systems and Knowledge Discovery.
- [4] Miguel Angel Reyes; Thomas Novak,"Injuries surveillance and safety considerations for large-format leadacid batteries used in mining applications",2014 IEEE Ind. Appl.,date of conference 27 October,20
- [5] P. Deshpande and M. S. Madankar, "",Techniques improving throughput of wireless sensor network: A survey,"" in Proc. Int. Conf. Circuit, Power Comput. Technol., Mar. 2015, pp. 1–5
- [6] Pan kunkun, Li xiangong,"Reliability Evaluation of coal mine IoT",IEEE Ind. Appl.,date of conference 17-18 October,2014.Vol-
- [7] W. Bing, X. Zhengdong, Z. Yao, and Y. Zhenjiang, "",Study on coal mine safety management system based on „hazard, latent danger and emergencyresponses,"" Proc. Procedia Eng., vol. 84, pp. 172 177, Nov. 2014.
- [8] Y. K. Tan and K. Tseng, "",Low-voltage, DC grid-powered LED lighting system with smart ambient sensor control for energy conservation in green building,"" in Smart Grid Infrastructure & Networking. New York,NY,USA: McGraw-Hill, 2013
- [9] J. Dickens and R. Teleka, "",Mine safety sensors: Test results in a , pp. simulated test stope,"" in Proc. 6th Robot. Mechatronics Conf., Oct. 2013 105 110.
- [10] Song Dongdong, Len hongiu, Wanghoitang,"Development of a coal mine intelligent safety monitoring management system based on fuzzy interface system", IEEE Ind. Appl.,date of conference 24-28 June, 2012.