

IoT based Smart Grid Energy Management System with Artificial Intelligence

Dr. A. Rubymeena

Associate Professor

Electrical and Electronics

Engineering,

Government College of Engineering,

Dharmapuri.

Jagadeshwari. N

UG College Student

Electrical and Electronics

Engineering,

Government College of Engineering,

Dharmapuri.

Priyanka. K

UG College Student

Electrical and Electronics

Engineering,

Government College of Engineering,

Dharmapuri.

Gobika. G

UG College Student

Electrical and Electronics Engineering,

Government College of Engineering,

Dharmapuri.

Sivanantham. V

UG College Student

Electrical and Electronics Engineering,

Government College of Engineering,

Dharmapuri.

Abstract - The power grid delivers electricity from power plants to homes and businesses across the nation. The vast network of power generation, transmission and delivery, it ensures we can function in the modern world. We hope to describe our electricity system, explaining how the power grid works as vulnerabilities, and how it could be improved whether you call it the power grid, power distribution grid, electrical grid, or national grid, this electrical network generates and distributes electricity across a large area. The power grid does three things ensures best practice use of energy resources, provides greater power supply capacity, and makes power system operations more economical and reliable. An electrical grid is a complex power generation, transmission, and distribution entities network. Grid operators that manage energy production and delivery in the regional entities that controls electrical energy as it travels through a fixed infrastructure. The system model is proposed to control the operation of power grids through internet connectivity around the world called Smart Grid. The system also includes the grid power autonomous based on Artificial Intelligence system during the emergency situation or electrical hazard. The electrical grid is responsible for generating, transmitting, and distributing electricity to consumers. However, traditional power systems face issues such as energy losses, poor monitoring, and slow response during faults. This paper proposes an IoT-based Smart Grid Energy Management System with Artificial Intelligence which improves reliability, reduces energy wastage, and ensures safe operation during emergency conditions.

Keywords: Smart grid, Energy Management, Internet of Things (IoT), Artificial intelligence, Remote monitoring.

INTRODUCTION

The rapid growth of renewable energy integration, distributed energy resources (DERs), and intelligent monitoring technologies has transformed conventional power systems into smart grids. A grid-connected smart grid enables bidirectional power flow, improved reliability, real-time

monitoring, and enhanced operational efficiency. However, effective energy management remains a hazardous challenge due to fluctuations in renewable generation, varying load demand, and grid stability concerns. Recent studies have highlighted the importance of stability assessment and converter integration in modern power systems. Although significant advancements have been made in optimisation and control techniques, the combination of Internet of Things technology with Artificial Intelligence for real-time smart grid energy management remains an active research area. IoT enables continuous monitoring of voltage, current, power, and load conditions through interconnected sensors and communication networks. AI-based algorithms can analyse real-time data to predict load demand, enhance energy distribution, and enhance grid stability. Therefore, this work proposes an IoT-based Smart Grid Energy Management System with Artificial Intelligence for a grid-connected environment. The proposed system integrates real-time data acquisition, intelligent decision-making algorithms, and optimized power control strategies to improve efficiency, reliability, and cost-effectiveness. The system aims to enhance energy utilization, reduce operational cost, and ensure stable grid interaction under varying load and generation conditions.

LITERATURE SURVEY

The development of smart grids and microgrids has attracted significant research attention due to the increasing penetration of renewable energy sources and distributed generation. Various approaches have been proposed to improve grid stability, optimization, control strategies, and

energy management. Several researchers have contributed to the growth of energy management systems for smart grids and microgrids.

Shi *et al.* [1] proposed a grid strength assessment method for evaluating small-signal synchronization stability in grid-following and grid-forming converters, highlighting the need for robust control strategies in grid-connected environments. Optimization techniques play a vital role in improving microgrid performance.

Askar Zadeh [2] introduced a memory-based genetic algorithm to optimize power generation in microgrids, improving economic efficiency.

Similarly, Sarfi *et al.* [3] presented a multi-objective economic-emission dispatch model to balance operational cost and environmental impact. These works demonstrate the significance of intelligent optimization in distributed energy systems. Energy Management Systems (EMS) are essential for coordinating distributed resources efficiently.

Lee *et al.* [4] designed and implemented a microgrid EMS architecture for real-time monitoring and control.

Agent-based control strategies were further explored by Sujil and Kumar [5], while Gao *et al.* [6] developed a control system based on the freedom structure to enhance microgrid flexibility and performance.

Furthermore, Daneshi and Khorashadi-Zadeh [7] analysed reliability and economic considerations in microgrid EMS, emphasizing integrated control approaches.

Meliani *et al.* [8] reviewed the current state and future trends of energy management in smart grids, highlighting the importance of intelligent monitoring and optimization techniques.

The application of IoT technology in smart grids has been explored by Balasubramanian and Singh [9], who developed an IoT based energy management framework for efficient load control. Similarly, Krishnan and Jacob [10] proposed an IoT-based efficient energy management method using DHOCSA optimization techniques.

Advanced technologies and challenges in smart grid systems were discussed by Bani Younis *et al.* [11], while Kumar *et al.* [12] reviewed various energy management techniques used in smart grids.

Machine learning based intelligent energy management approaches were introduced by Sivasubramanian *et al.* [13] to enhance decision-making capabilities. In addition, Keshri and Vishwakarma [14] studied different strategies and

applications of energy management systems in modern smart grid environments.

These studies highlight the importance of intelligent control, optimization algorithms, and IoT technologies in improving energy efficiency and system reliability. However, many existing systems focus mainly on optimization and monitoring, with limited real-time user interaction. Therefore, the proposed system aims to develop an IoT-based energy management framework that enables remote monitoring and control of electrical loads through a web interface, improving both energy efficiency and user accessibility.

BLOCK DIAGRAM

The fig. 1 shows the proposed system which presents an IoT-based smart grid energy management system and monitoring systems for smart grids to enhance safety, reliability, and efficient utilization electrical power.

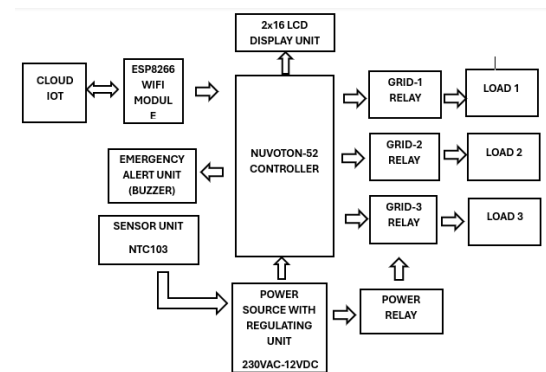

Fig. 1. Block Diagram of IoT-based smart grid energy management system with Artificial Intelligence.

The system is designed to monitor the operating condition of multiple grid loads and detect abnormal situations such as overheating. It integrates temperature sensing units, a Nuvoton-52 microcontroller, relay control circuits, and a Wi-Fi communication module to ensure continuous monitoring and control of the grid. The controller processes the data obtained from sensors and automatically manages the connected loads through relay switching. Additionally, the system enables real-time data transmission to the cloud platform for remote monitoring and analysis. By combining sensing, automation, and IoT communication, the proposed system improves grid protection, prevents electrical hazards, and supports efficient energy management in smart grid applications.

HARDWARE SETUP

The fig. 2 illustrates the hardware components which are the main elements used to implement the proposed system. Each

component performs a specific function to ensure proper operation of the project.

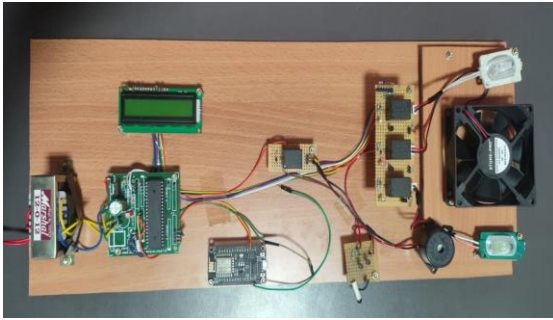

Fig. 2. Hardware setup of the system.

1. Nuvoton-52 Microcontroller

The Nuvoton-52 microcontroller is the main controller used in the system. It processes the data received from sensors and controls all the components of the project. The microcontroller executes the program written in embedded C.

It manages devices such as the LCD display, relay, buzzer and Wi-Fi module. It also sends commands and processes the output signals. Thus, it coordinates and controls the entire system operation.

2. 2×16 LCD Display

The 2×16 LCD display is used to show the system output information. It can display two lines with sixteen characters in each line. It is connected to the microcontroller to receive display data. The display helps the user to easily monitor the system condition. It also consumes very low power

3. ESP8266 Wi-Fi Module

The ESP8266 Wi-Fi module is used to provide internet connectivity to the system. It enables the project to send data to the cloud or web page. The module communicates with the microcontroller using serial communication. It supports IoT based monitoring and remote data access. The ESP8266 helps in fast and reliable wireless communication. Hence it is widely used in smart systems.

4. NTC-103 Thermistor

The NTC-103 thermistor is a temperature sensing device used for monitoring temperature. NTC means Negative Temperature Coefficient, where resistance decreases when temperature increases. It detects temperature changes in the system. The sensed data is sent to the microcontroller for processing. It provides accurate and reliable temperature measurement. Therefore, it is used for temperature monitoring applications.

5. 5V Relay

The 5V relay is an electrically operated switch used to control high power loads. It works based on an electromagnetic mechanism. The microcontroller sends a signal to activate or deactivate the relay. This allows safe control of devices operating at higher voltage levels. It provides electrical isolation between control circuit and load circuit. Hence it ensures safe switching operation.

6. Buzzer

The buzzer is an electronic sound producing device used for alert indication. It generates sound when a fault or abnormal condition occurs in the system. The buzzer is controlled by the microcontroller based on programmed conditions. It helps to notify the user immediately about system problems. The device consumes low power and responds quickly. Thus, it improves system safety.

7. 7805 Voltage Regulator

The 7805-voltage regulator is used to provide a constant 5V DC output. It converts higher input voltage such as 12V into stable 5V supply. This regulated voltage is required for components like the microcontroller and LCD. It protects the circuit from voltage fluctuations. The regulator ensures stable and reliable operation of the system. Hence it is commonly used in embedded circuits.

HARDWARE IMPLEMENTATION

The fig. 3 depicts the hardware implementation of the proposed IoT-based Smart Grid Energy Management System which consists of a microcontroller, communication module, display unit, relays, loads and monitoring components.

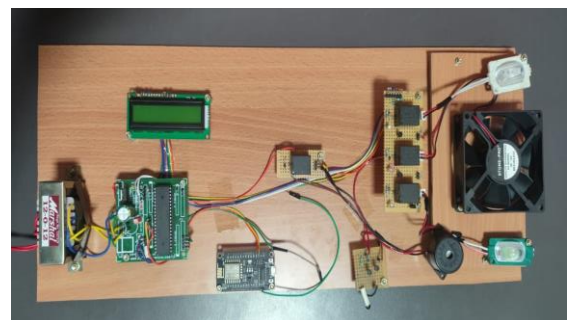

Fig.3. Hardware implementation of IoT based Smart grid Energy Management System

The microcontroller serves as the central unit of the system, coordinating and controlling the operation of various electrical loads. An LCD display is incorporated to provide real-time information about the system status and power usage, making it easy to monitor. Relays are used to manage the switching of different loads in the smart grid setup.

Devices such as lights and fans are connected through relay modules, allowing them to be controlled automatically via the IoT platform. Additionally, a buzzer is included to give alert signals during system operation. All the hardware components are assembled on a prototype board to effectively prove the working of the smart grid energy management system.

AI BASED CONTROL

In this project, a basic Artificial Intelligence concept is implemented using rule-based logic. Instead of depending on complex machine learning techniques, predefined conditions are programmed into the microcontroller. Based on these conditions, the system continuously monitors the grid status and makes decisions automatically.

The logic used in the system is given below:

IF overload condition detected → Turn OFF grid, Activate buzzer.

IF fault condition detected → Activate buzzer, turn off grid.
ELSE → Continue normal operation.

RESULT AND DISCUSSION

The proposed IoT-based Smart Grid Energy Management System was successfully executed using the developed hardware prototype and the web-based monitoring interface. The system was tested to verify the operation and control of the connected loads.

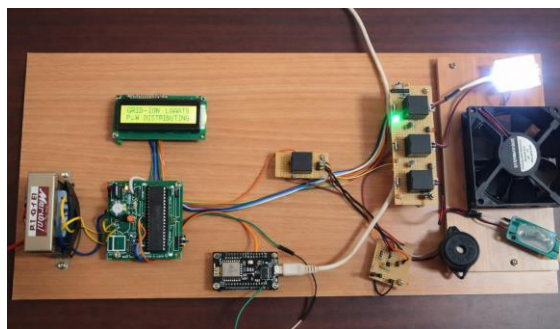

Fig.5. Grid-1 ON condition of the system



Fig.6. Display of Grid-1 ON condition

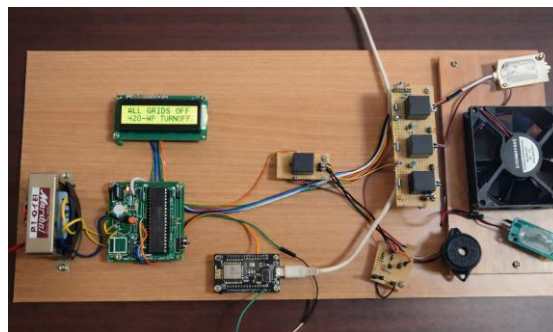

Fig.7. All grids turn off condition of the system

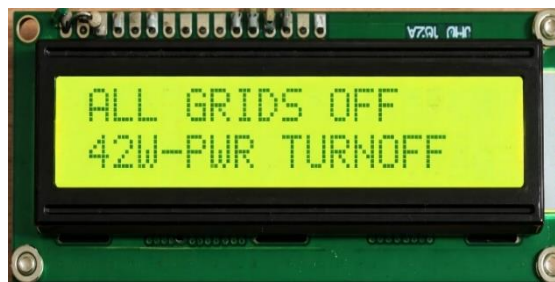

Fig.8. Display of all grids turn off.

The monitoring webpage was used to control the grid operations remotely. Through the webpage interface, the user can switch the grid ON and OFF and control the connected loads. When the user selects the control option on the webpage, the command is sent to the microcontroller which activates the corresponding relay to control the loads.

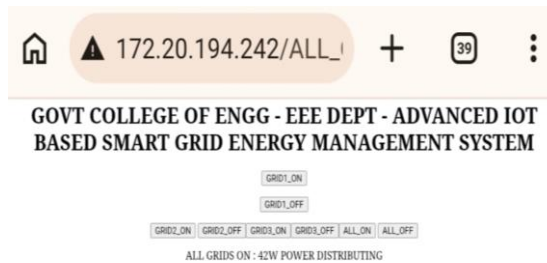

Fig.9. IoT webpage showing real-time grid monitoring and control

The webpage also displays the current status of the grids and the power distribution in the system. The LCD display in the hardware setup shows the operating condition of the system during execution. The experimental results confirm that the proposed system can efficiently monitor and control energy usage through the IoT platform.

Thus, the developed system provides efficient remote monitoring, load control, and better energy management in a smart grid environment.

CONCLUSION

The proposed smart grid system offers an efficient way to control and manage electrical power using IoT and cloud-based services. The controller unit allows users to monitor and operate electrical devices remotely through an internet connection, making the system more convenient and flexible. An AI-based emergency shutdown feature is included to enhance safety by automatically responding to electrical faults or risky situations. This system also reduces the dependency on traditional manual lever board operations. In the future, it can be further improved into a fully automated soft-switching system that can be easily controlled using a smartphone application.

REFERENCES

- [1] [1] Q. H. Shi, W. Dong, and G. Wang, "Grid Strength Assessment Method for Evaluating Small-Signal Synchronization Stability of Grid-Following and Grid-Forming Converters Integrated Systems," *IEEE – Modern Power Systems and Clean Energy*, vol. 13, no. 1, Jan. 2025.
- [2] [2] A. A. Zadeh, "A memory-based genetic algorithm for optimization of power generation in a microgrid," *IEEE Transactions on Sustainable Energy*, 2017.
- [3] [3] V. Sarfi, H. Livani, and L. Yliniemi, "A new multi-objective economic-emission dispatch," *IEEE Transactions*, 2017.
- [4] [4] E.-K. Lee, W. Shi, R. Gadh, and W. Kim, "Design and Implementation of a Microgrid Energy Management System," *Incheon National University, Information and Telecommunication Engineering*, Korea, Nov. 2016.
- [5] [5] A. Sujil and R. Kumar, "Smart micro grid test system for agent-based energy management system," in *2016 7th India International Conference on Power Electronics (IICPE)*, IEEE, 2016.
- [6] [6] L. Gao, Y. Sun, and H. Li, "Research on energy micro grid control system based on the structure of FREEDM," in *2016 IEEE 8th International Power Electronics and Motion Control Conference*, 2016.
- [7] [7] H. Daneshi and H. Khorashadi-Zadeh, "Microgrid energy management system: A study of reliability and economic issues," in *IEEE Power and Energy Society*, 2012.
- [8] [8] M. Meliani, A. El Barkany, E. Ikram, and D. A. Moumen, "Energy management in the smart grid: State-of-the-art and future trends," *International Journal of Engineering Business Management*, vol. 13, Jul. 2021. doi:10.1177/18479790211032920.
- [9] [9] C. Balasubramanian and R. L. R. Singh, "IoT Based Energy Management System in Smart Grid," IEEE, 2020.
- [10] [10] P. R. Krishnan and J. Jacob, "An IoT Based Efficient Energy Management in Smart Grid Using DHOCSA Technique," *International Journal of Energy Research*, 2021.
- [11] [11] R. Bani Younis, M. Alkasassbeh, and A. Aldweesh, "Advanced Technologies to Smart Grid Systems: Challenges and Demands," *IEEE Access*, 2021.
- [12] [12] A. Kumar, M. Singh, and M. A. Hasan, "Techniques of Energy Management in Smart Grid," *Journal of Electrical Systems*, doi:10.52783/jes.8692.
- [13] [13] B. K., S. Sivasubramanian, C. S. Nivetha, R. Senthil Kumar, and M. Soundari, "Intelligent Energy Management System for Smart Grids Using Machine Learning Algorithms."
- [14] [14] V. Keshri and S. K. Vishwakarma, "Study of Energy Management System of Smart Grid," *International Journal of Scientific Research in Engineering and Management*, 2020.