

Intelligent Predictive Traffic Light Information for Improving Fuel Economy and Reduction of CO₂ Reduction

Poornimarani. R¹

¹Electronics and Communication Engineering,
Dr.N.G.P Institute of Technology
Coimbatore, Tamilnadu, India

Mr. R. Karthik²

²Electronics and Communication Engineering,
Dr.N.G.P Institute of Technology
Coimbatore, Tamilnadu, India

Abstract - Recent survey shows, one of the top CO₂ emitters all over the world is transporters. Especially in the major cities, transporters play the key role in CO₂ emission in the traffic signal intersections. Vehicle engine emits more CO₂ during idling period, frequent stops and accelerations which consume more fuel in the vehicles. It's been observed, the vehicles maintain the average speed and minimum waiting time reduces fuel consumption and 60% of CO₂ reduction. A system is necessary in all the vehicles to display the required average speed which reduces the CO₂ emission and less fuel consumption. The system Intelligent Predictive Traffic Light Information displays the recommended average speed and special instructions for a vehicle in the traffic signal intersection, helps the driver for smooth driving. The data exchange takes place when the vehicle enters into the communication range. The vehicle On-Board Unit (OBU) receives the signal status from the Traffic signal control. Based on the received information, the driver is suggested with recommended speed to pass the signal intersection. The recommended speed is calculated based on the signal count down, distance and front vehicle speed. The existing system based on Branch and Bound (BB) algorithm was used to determine the recommended speed of the vehicle. The BB algorithm does not consider the front vehicles and their speed. In order to overcome this drawback, Maximize Throughput Model (MaxTM) is proposed for smoothing vehicle travels.

Keywords— *Wireless communication, CO₂ Emission, Vehicle On-board Unit (OBU), Road Side Control Unit (RSU), Maximize Throughput Model (MaxTM)*

I. INTRODUCTION

Carbon dioxide emissions cause ocean acidification, the decrease in the pH level of the oceans as CO₂ becomes dissolved. Carbon dioxide (CO₂) is emitted through human activities such as combustion of fossil fuels (coal, natural gas, and oil) for transport, although certain industrial processes. Electricity, Transport and Industry are the main sources of CO₂ emission.

In the survey conducted by one of the leading automobile firm in 2013, India is the third largest emitter of CO₂. The largest emitter of CO₂ is Road Transport about 87%, projected to increase ~134% by 2020 shown in table 1. This is majorly due to three factors. Driving manners is one of the major factor for more fuel consumption which in turns to emit more CO₂. The second factor is the vehicle technology should be

improved by the vehicle manufacturing companies in their engine design to reduce fuel consumption. The road infrastructure should be good enough to handle the vehicles for the smooth pass through. The Improved driving manners can save vehicle's fuel consumption by Accelerating [5] slowly and smoothly, driving in the speed limit, maintaining a steady speed and anticipating vehicle's stops and starts.

TABLE I
CO₂ EMITTERS IN INDIA

Sectors	CO ₂ (million tons)
Electricity	715.83
Transport	138.86
Other energy activity	138.15
Cement	129.92
Iron & steel	116.96
Other manufacturing industry	158.98
Total	1398.7

II. RELATED WORK

A. Adaptive Traffic Light Control Model

The adaptive fuzzy control method [1],[2] is mainly dealing with the green light phase extension time based on the detected traffic flow in the other directions of the signal intersection. The adaptive traffic light control method, vehicles cannot get any information about the current traffic light phases. There are two key parts 1) design a fuzzy logic controller and 2) detect the traffic flow conditions. In this method three stages are analyzed when designing a fuzzy logic controller. The selection of performance variables is the first stage, i.e., inputs and outputs. The determination of the fuzzy rules set the second stage. If-Then statement is used in this stage to indicate the inputs and outputs relationship. The defuzzification process for converting the outputs' value to a crisp value is the third stage. Special detection tools are used at certain distance from the intersection for traffic flow information detection. Arrival, Queue and Volume are the input variables. Extension is the output variable of the adaptive fuzzy logic. Adaptive fuzzy control method more than 50% of CO₂ was reduced.

B. Open Traffic Light Control Model

In Open traffic light control model [2], all vehicles have installed with the Global Positioning System (GPS) devices and ETC in-vehicle devices called on-board units (OBUs). OBUs are used to send traffic flow information to traffic lights by wireless communication. The vehicle state information, such as the current speeds, the distances to the stop line, acceleration, deceleration and the moving directions (e.g., go straight, turn right, or turn left) are collected by the GPS devices installed in the vehicles. Then, in the traffic control center, traffic lights' cycles are dynamically adjusted based on the received detected traffic flow information by a certain traffic light control algorithm. An existing CO₂ emissions model is used to calculate the CO₂ amounts but not considering the front vehicle. The OTLCM performed much better than the adaptive traffic light control model. The CO₂ emission, average waiting time and short-time stop times were reduced, and the fuel economy was greatly improved. The OTLCM reduced the CO₂ emissions by 60% compared with the adaptive traffic control model.

III. SYSTEM MODEL

The complete cycle of the traffic signal system includes the sequence of traffic light phases [4]. The time period can be set for the complete cycle for particular light status in the traffic light control system. The PIC microcontroller is used in the traffic signal system for the signal cycles and the signal countdown message (SCM) might vary for each and every traffic signal. Traffic signal control system controls the traffic light cycle for the configured intervals to pass the vehicles in the traffic intersection. The system is controlled by the microcontroller for light phase switching (green, red and yellow) and display the time remaining for the next signal change shown in figure 1. The signal status and the signal countdown details are mandatory for determining the recommended speed for a particular vehicle.

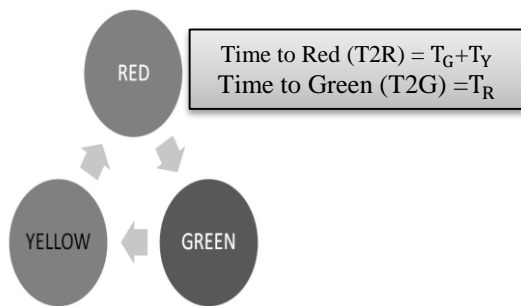

Fig. 1 Traffic Signal System Cycle

The complete system is called as road side control unit (RSU) includes traffic signal control system and the Zigbee communication system. The Zigbee communication system is used to broadcast these details to the vehicle. Normally the range of the Zigbee signal is around that particular signal intersection and this range is called as Zigbee lane. The vehicles entering into this lane contains the on-board units

(OBU) attached with Zigbee transceiver which communicates with the road side unit (RSU). The OBU includes the microcontroller and display unit (LCD). The microcontroller calculates the recommended speed for the vehicle entering in the Zigbee lane and provides the instructions to the drivers.

A. On Board Unit And Road Side Control Unit

Now days, all the vehicles are inbuilt with the On-Board Units (OBUs) by default for controlling the function of the vehicles such as monitoring the vehicle speed, fuel status, engine health and Air-bag controls.

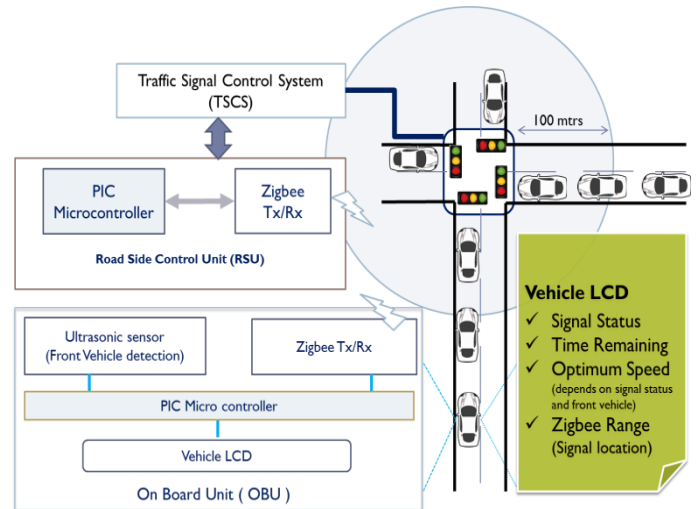

Fig. 2 Overview of predictive traffic light system

OBU displays these details to the driver for better driving. 9600 OBU contains the Ultrasonic sensor, Microcontroller, Zigbee communication which detects the Zigbee signal while entering into the Zigbee lane shown in figure 2. Zigbee CC2500 model is used for the wireless [1] communication between the vehicle and RSU. CC2500 RF Module is a transceiver module which provides easy to use RF communication at 2.4 GHz and can be used to transmit and receive data at 9600 baud rates. Ultrasonic sensor is used to detect movement of metal targets (front vehicle) and to measure the distance (front vehicle). Once the vehicle enters into the Zigbee lane, OBU sends the current details of the vehicle such as ID of the on board unit, position of the vehicle, current speed of the vehicle and current direction of a vehicle.

Road side-control Unit (RSU) contains the microcontroller and Zigbee communication which broadcast the ID of the road side control unit, position of the road side control unit, current signal status and length of the waiting queue. The waiting queue length determined by comparing the Road Side Unit and last incoming stopped vehicle (OBU). The OBU receives these details for calculating optimum speed required to pass the traffic signal. Once the recommended speed is calculated, the details will be displayed in the LCD along with the instruction to the driver. Instructions are decided based on the Maximize Throughput Model (MaxTM) Algorithm. MaxTM is to maximize the throughput of the traffic intersection; it reduces the CO₂ emission, average waiting time.

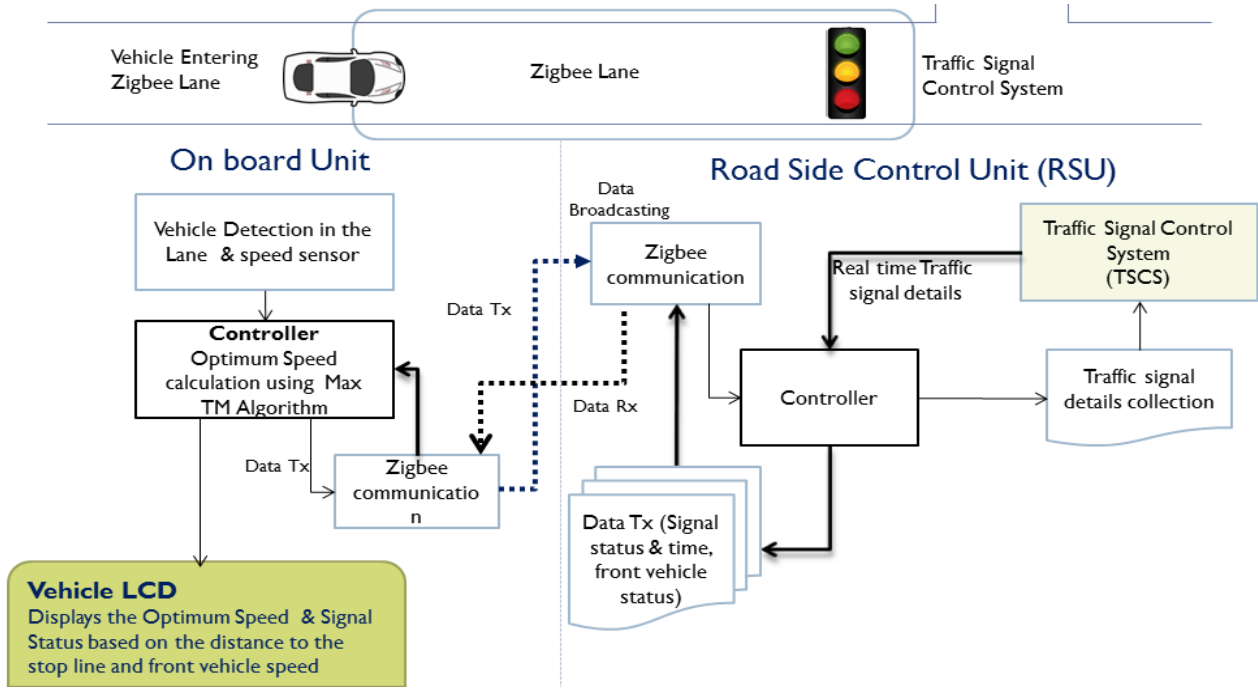

Fig. 3 Functional diagram of predictive traffic light system.

B. Maximize Throughput Model

Maximize Throughput Model (MaxTM) is proposed to minimize the CO₂ emissions by considering traffic information nearby the intersection. The idea and strategy of the MaxTM is to maximize the throughput of the intersection so that the vehicles stopped by the signal can be minimized and the vehicles idle periods as well as the fuel consumption can also be minimized. Under this consideration, OBU calculates the recommended speed (Sr) with the collected information for maximizing the possibilities of pass through the intersection by a smooth eco-driving style.

The principle of this approach is that determines the current vehicle speed (Sc) and determines if any front vehicles, then it calculate the recommended speed based on the front vehicle speed (Sf), otherwise it suggests the recommended speed and the instructions to the driver. Table II explains the signal conditions and the display message to the driver for improving driving conditions. The computation model is based on the Maximize TM algorithm and the following table III describes the parameters used for recommended speed calculation.

TABLE II
DECISION TABLE BASED ON CONDITIONS

Signal Status	Front Vehicle	Recommended Speed	Instructions
Green	No	$S_c = S_r$, $S_r < S_{max}$	Maintain Speed
		$S_c < S_r$	Raise speed
	Yes	$S_r = S_{min}(S_r, S_f)$	Front vehicle, recommended Speed
Red	No	$S_r = S_{min}$, if T2G is longer	Slow down (free flow speed)
		$S_r = S_{min}$, if T2G is less	Free flow speed
	Yes	$S_r = S_{min}(S_r, S_f)$	Front vehicle, recommended Speed

TABLE III
MAXIMIZE THROUGHPUT MODEL PARAMETERS

Parameters Used	Denoted as
Recommended speed	S_{rec}
Current Speed	S_c
Distance	D
Front vehicle speed	S_f
over-all traffic light cycle	$C_{cycle} = T_g + T_r + T_y$
Duration time of the three phases	$T_g, T_r, \text{ and } T_y$
Remaining time of the current light phase	$L_g, L_r, \text{ and } L_y$
Minimum & Maximum speed	S_{min}, S_{max}
$t = d/S_{current}$	How much time would be spent on passing the distance d

C. OBU and RSU Workflows

The RSU broadcasts the signal range (Zigbee lane) about some defined perimeter. The vehicle OBU detects the Zigbee range and receives the data from RSU. The computation takes place in the OBU for the recommended speed and the instructions to the drivers according to the signal conditions, time remaining and vehicle distance. The RSU and OBU workflow shown in figure 3.

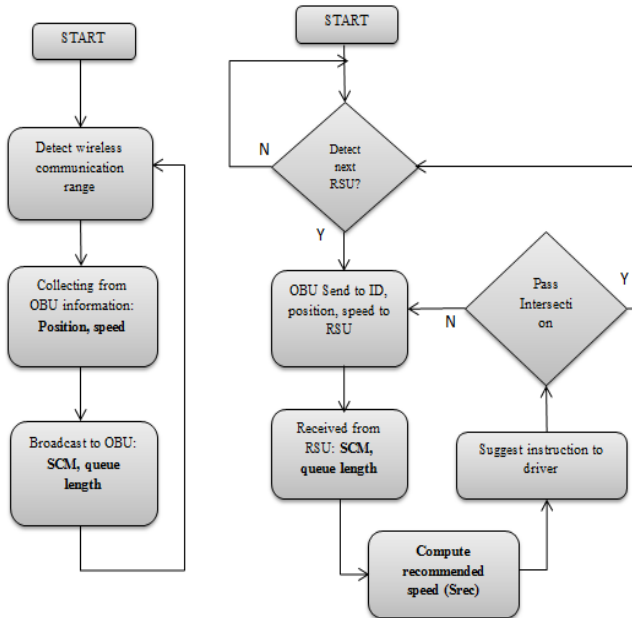

Fig. 4 (a) RSU workflow (b) OBU Workflow of the Driver Behaviour Suggestion System

R2V (Road side control Unit to Vehicle OBU) transmission contains ID of the RSU (RID), Position of the RSU (XR, YR), Type of current phase of each direction, Remaining time SCM and Length of the waiting queue of each direction (QDd). V2R (Vehicle OBU to Road Side unit) transmission contains OBU (OID), position of the vehicle (XO, YO), current speed of the vehicle (Sc) and current direction of the vehicle (Dc).

D. Results in Two Conditions

1) When front vehicle is not detected: The recommended speed calculation is described using the data received. Table IV explains the parameters and values. If consider, current light phase is green, distance to the stop line is 100m from the Zigbee range and remaining green light timing is 20s then the system inform the driver to the recommended speed using Max TM Algorithm.



Fig. 5 LCD unit of vehicle OBU

Figure 5 shows the vehicle OBU LCD for displaying the vehicle speed, signal status, the determined recommended speed using Max TM Algorithm and the remaining countdown.

TABLE IV
RESULT PARAMETERS AND VALUES

Parameters	Values
d (distance)	100m
Tg	20s
Tr	20s
Ty	2s
Time to RED	22s
Time to GREEN	20s
Current speed	33km/h
Recommended speed	50km/h
Instruction	Recommended speed

2) When front vehicle is detected: Table V lists the parameters and values. If consider, current light phase is green, distance to the stop line is 100m from the Zigbee range, remaining green light timing is 50s and front vehicle speed is 35km/h then the system inform the driver to the recommended speed is 20km/h using Max TM Algorithm. Figure 6 shows the vehicle OBU LCD for displaying the vehicle speed, signal status, the determined recommended speed using Max TM Algorithm and the remaining countdown and the instruction to the driver when front vehicle is detected.



Fig. 6 LCD unit of vehicle OBU.

TABLE V
RESULT PARAMETERS AND VALUES

Parameters	Values
d (distance)	100m
Tg	50s
Tr	50s
Ty	2s
Time to RED	52s
Time to GREEN	50s
Current speed	33km/h
Front vehicle speed	35km/h
Instruction	Vehicle front , Go slow
Recommended speed	20km/h

IV. CONCLUSION

The Intelligent Predictive Traffic Light Information for Improving Fuel Economy and reduction of CO₂ Emission system displays the recommended speed to the driver for better driving. Compared to the existing Open Traffic light control model [2] (OTLCM), Traffic Light Sensing with Probe Vehicles [8], the Intelligent Predictive Traffic Light Information for Improving Fuel Economy and reduction of CO₂ Emission system provides the instructions to the driver that would help for better driving in the traffic intersection and improves fuel economy by reducing the CO₂ emissions [2]. In this paper, a single traffic control system is considered in the traffic intersections.

In future, multi traffic signal intersections can be analysed using an adaptive OBU driving suggestion algorithm.

REFERENCES

- [1] B. Zhou, J. Cao, X. Zeng, and H. Wu, "Adaptive Traffic Light Control in Wireless Sensor Network-Based Intelligent Transportation System," Vehicular Technology Conference Fall IEEE 72nd, pp.1-5, 6-9, 2010.
- [2] Behrang Asadi and Ardalan Vahidi "Predictive Cruise Control: Utilizing Upcoming Traffic Signal Information for Improving Fuel Economy and Reducing Trip Time", IEEE Transaction control systems technology, vol. 19, no. 3, pp. 707-714, 2011.
- [3] Chunxiao Li and Shigeru Shimamoto, "An Open Traffic Light Control Model for Reducing Vehicles CO₂ Emissions Based on ETC Vehicles" IEEE trans. vehicular technology, vol. 61, no. 1, pp. 97-110, 2012.
- [4] E. Azimirad, N. Pariz, and M. B. N. Sistani, "A novel fuzzy model and control of single intersection at urban traffic network," IEEE System, vol. 4, no. 1, pp. 107-111, 2010.
- [5] F.-Y. Wang, "Parallel control and management for intelligent transportation systems: Concepts, architectures, and applications," *IEEE Trans. Intell. Transp. Syst.*, vol. 11, no. 3, pp. 630-638, Sep. 2010.
- [6] H. Huang, P. Luo, M. Li, D. Li, X. Li, W. Shu, and M. Wu, "Performance Evaluation of Suvnet with Real-Time Traffic Data," IEEE Transaction Vehicular Technology, vol. 56, no. 6 Part 1, pp. 3381- 3396, 2007.
- [7] K. Ahn, H. Rakha, A. Trani, and M.V. Aerde, "Estimating vehicle fuel consumption and emissions based on instantaneous speed and acceleration levels," *Journal of Transportation Engineering*, vol. 128, no.2, pp. 182-190, 2002.
- [8] L. Qu, L. Li, Y. Zhang, and J. Hu, "PPCA-based missing data imputation for traffic flow volume: A systematical approach," *IEEE Trans. Intell. Transp. Syst.*, vol. 10, no. 3, pp. 512-522, Sep. 2009.
- [9] M. Alsabaan, K. Naik, T. Khalifa, and A. Nayak, "Vehicular Networks for reduction of fuel consumption and CO₂ Emission," *2010 8th IEEE International Conference on Industrial Informatics (INDIN)*, pp.671-676, 13-16 July 2010.
- [10] M. Sanches, J. Cano, and D. Kim, "Predicting traffic lights to improve urban traffic fuel consumption," in Proceedings. 6th ITS Conference, pp. 331-336, 2006.
- [11] N. A. Chaudhary, V. G. Kovvali, and S. M. Alam., "Guidelines for Selecting Signal Timing Software," Product 0-4020-P2. Texas Transportation Institute, College Station, TX. September 2002.
- [12] W. H. Lee, Y. C. Lai, and P. Y. Chen, "Decision-tree based green driving suggestion system for carbon emission reduction," *2012 12th International Conference on ITS Telecommunications (ITST)*, pp. 486-491, 5-8 Nov. 2012.
- [13] Yanmin Zhu, Xuemei Liu, Minglu Li, and Qian Zhang "POVA: Traffic Light Sensing with Probe Vehicles" IEEE Transaction on parallel and distributed systems, vol. 24, no. 7, pp.1390-1400, 2013.