

# Implementation of Vehicle Mishap Averting System using Arduino Microcontroller

R. S. Rakul

UG Student, Department of EIE  
Hindusthan College of Engg. & Tech.  
Coimbatore, India

S. Ravia

UG Student, Department of EIE  
Hindusthan College of Engg. & Tech.  
Coimbatore, India

K. N. Thirukkuralkani

Assistant Prof., Department of EIE  
Hindusthan College of Engg. & Tech.  
Coimbatore, India

**Abstract**— The rapid growth in the transport sector has resulted in an increase of the accidents every day. The accident mainly occurs due to our carelessness and breaking of traffic rules. In this paper, the main goal of the proposed system is to avert collisions between vehicles mainly occurring in hairpin bends, short corners, blind curves, etc. by providing indication and making the vehicle drivers' alert. If any problems say, vehicle breakdown or repair of the vehicle, the interrupt signal will be sent to the control room thereby the problems can be solved. This system makes use of ultrasonic sensor and other embedded systems.

**Index terms**—Ultrasonic transceiver (URS), Wi-Fi router, Arduino ATmega microcontroller, LED, Buzzer, Radio Frequency Identification (RFID)

## I. INTRODUCTION

The aim is to prevent the accidents by providing ultrasonic transceiver in roadways at necessary places such as diversion zones, hair-pin bends, and other accident-prone zones for indicating about the respective places well in advance before reaching the appropriate location vehicle with LED indication and as well as by an Android message display. The accidents due to the carelessness of the driver are prevented by alerting him through the buzzer and light indication as well by voice recognition. Similarly, if the traffic occurs due to the repair or accidents of the vehicle, the transceiver sends the signal to the controller through the Wi-Fi router and shows the message about the spot where the problem has occurred. Simultaneously if traffic occurs for a long time, an emergency message carrying the location will be sent to the controller room and therefore, emergency help can be provided.

The following bar graph Fig.1 gives the number of road accidents occurring in major states of India. Among it, Tamil Nadu contributes the first place in the occurrence of major road accidents [16]. A survey says that in India, for every minute, five persons are losing their lives in the accidents[15].

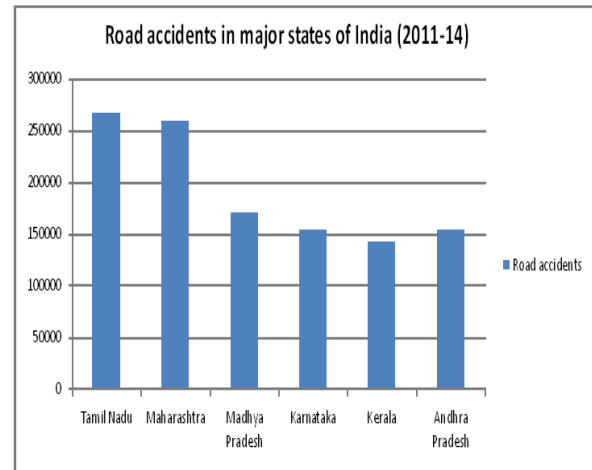

Fig.1 Accidental survey in major states of India

A life lost in a road accident is unforeseen and absolutely unnecessary. In many accidents, the faults haven't been recognized and it's difficult to detect how the problem has occurred.

## II. LITERATURE SURVEY

**S.P.Bhumkar et al** has described the new fatigue detection of a driver and has proposed an intelligent car system for accident prevention [1]. **D. Haripriya et al** has described the prevention of road accidents occurred due to the poor indication of sign boards, drowsy state and drunken state of drivers in both two wheeler's and four wheeler's [2]. **S.Uvaraja et al** has described the number of accidents involving the train and has proposed a system that aims at averting collisions between trains and furthers it is used to provide the information on obstacles present in the track to the driver [3]. **K.P.Sreevishakh et al** has proposed an automatic accident prediction and the notification system using AMR and Sonar sensor [4]. **Apeksha S. Chavan et al** has described the prevention of accident due to drowsiness of the driver and disturbing intruders [5].

## III. EXISTING METHOD

The mirror setup arrangements are made in the short bends and corners for viewing the approaching vehicle on the other side. However, it has several

drawbacks. The mirror may get damage because of animals (in hills) or it doesn't reflect the image when the climatic condition occurs like raining or covered with mist, etc also when the number of vehicles approaching one after other, it wouldn't be visible for the back-forth vehicle to see the opposing vehicle in corners. Also, there are several methods available for the fatigue prevention of the drivers and detection techniques using alcohol impact, accelerator, brake, clutch, etc [1]. But there is no proper solution for making other road users to take a safe turn in corners.

#### IV. OVERVIEW

The Unit has been designed to prevent an accident by collision. The 'heart' of the Unit is Arduino microcontroller which performs all the vital tasks of the system. And it will be discussed in the following subsequent sections. This system will receive information from the Ultrasonic transceiver, and accordingly transmit the data via the Wi-Fi router to the controller. Through the buzzer indication, light emitting display, and liquid crystal display, the vehicle information will be shown to the vehicle users [8]. The primary purpose of the system is to prevent collision between two or more vehicles when they take a turn on U-bends. The modules of the system are described in the following sections.

#### V. METHODOLOGY

The construction of the Mishap-averting Unit is as shown in Fig. 2. The working of the various components is explained below.

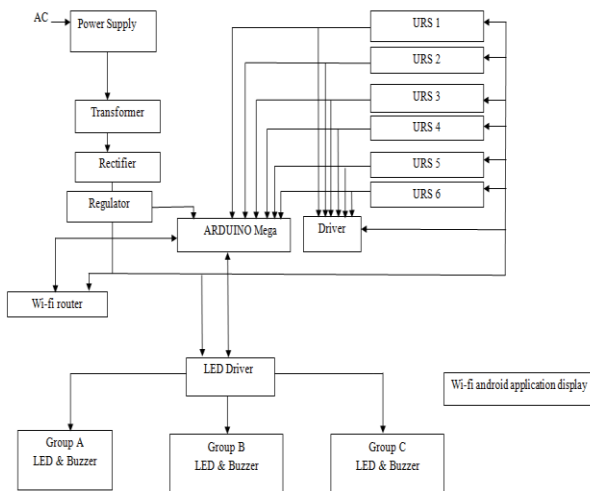

Fig.2 Mishap Averting System Block diagram

##### A. Power Supply Unit

The 230V AC supply is given directly to the transformer (0-12V, 1A). Since the circuit components require only DC supply, the bridge rectifier rectifies AC into DC supply as shown in this Fig. 3 diagram.

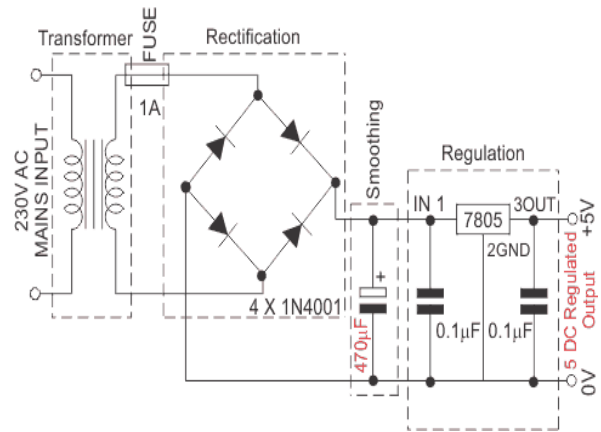

Fig.3 Power Supply Unit

##### B. Ultrasonic Transceiver

The Ultrasonic transmitter-receiver pair is connected to a Wi-Fi router and a power supply as shown in Fig. 2. The transmitter transmits the signal directly to the receiver that can detect the vehicle approaching towards the hairpin bend earlier at a distance of a few hundred meters. It requires a 5V DC as an input supply. When the vehicle is detected, a signal is sent to the system for it to work on the next stages of operation.

##### C. Wi-Fi Router

Wi-Fi router is setup on the main unit. Wi-Fi ESP 8266 module is used here. It requires 3.3V supply. They are activated by means of a signal from the ultrasonic transceiver. The transmitted signal of Ultrasonic sensor from the location spot is transmitted to the controller through the Wi-Fi router. Because it acts as a transmitting medium. The transmitted signal is used for further processing.

##### D. Arduino Microcontroller

Arduino microcontroller is used for its best feature such as high processing speed, easy to use analog-to-digital conversion, and low power requirement and capable of performing multitask at a time. It requires a 5V DC Power supply. It performs all control operations, fetching input signal, processing it and provides controlled output to other systems like LED, and Buzzer. The microcontroller program is programmed using Arduino 1.6.5 software. It is interfaced with Wi-Fi router through a serial communication.

##### E. Android display

An android application is developed, which is in .apk format. The programming is developed using Android Inventor software. When the signal via Wi-Fi router is received by the Wi-Fi hotspot of the android mobile phone, the traffic alert is displayed and alerted by voice recognition system.

**F. Main System**

The main system in the unit is used to perform most of the operations. It consists of several components including a Transmitting - Receiving unit, Wi-Fi medium for transmitting raw data to the controller from a remote location and a signal selector unit. This is the heart of the main unit. The circuit diagram representation of the complete unit is shown in Fig. 4.

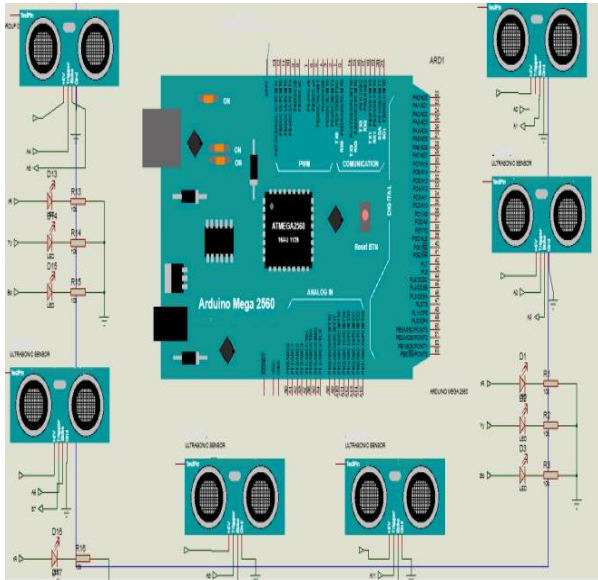
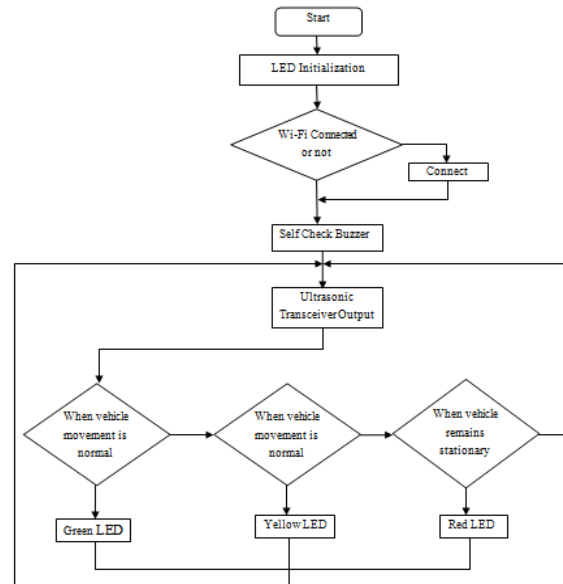

Fig.4 Circuit Diagram

**VI. WORKING**

To explain the working of the mishap-averting system, consider three units as shown in Fig. 4. The first unit is input unit which consists of ultrasonic transmitter-receiver pair on every bend. The second unit is control unit which consists of microcontroller and Wi-Fi router. The third unit is output unit which consists of LED, Buzzer, and Wi-Fi android application. When the vehicle at any of the hairpin bends is detected by the Ultrasonic transceiver it sends the signal to the microcontroller via wireless medium Wi-Fi router. The router transmits the signal to the android phone through Wi-Fi hotspot. The IP address of the mobile phone has to be configured with the Wi-Fi router's IP address with the help of a microcontroller. When the vehicle driver has installed this android application, the traffic information will be delivered as voice recognition [13]. Also, the detected signal will be indicated as an output at the other side of the bend by LED indication and Buzzer which are placed at the corner of the road. When the road is free, Green LED will glow, if any vehicle detection observed Yellow LED will glow and if there is any interrupt or the vehicle stood in between of ultrasonic transceiver and there is a no motion change of the vehicle for a certain period then Red LED will glow [6]. All these indications are provided with buzzer alarming. The following flowchart Chart 1 describes the programming sequence of the vehicle mishap averting system.

Chart 1 Flowchart of Vehicle Mishap Averting System



Using this android application, the vehicle traffic signal monitoring can be done from the controller room and an emergency contact can be made on viewing the notification in the android application [9]. It is shown in Fig. 5.

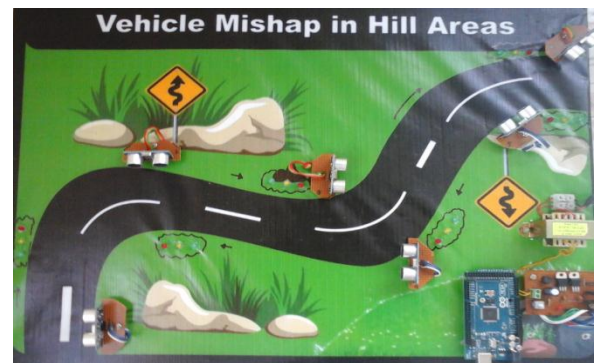

Fig.5 Vehicle Mishap Averting System

**VII. APPLICATION**

- i. The primary purpose is to avoid collision between the vehicles in the hairpin bend.
- ii. It is used for providing an Automatic alert about the traffic.
- iii. It can be used in high-frequency wireless technology.
- iv. It displays an alert notification as voice recognition about the traffic in the android application.

**VIII. RESULTS**

The vehicle arrival is detected and when the road is free, Green LED (indicated mark) will glow, this has been shown using Fig. 6.



Fig.6 Green LED display

The following android display Fig. 7 shows that there is no vehicle detection in any of the hairpin bends, so it displayed as “Fine”.



Fig.7 Android display showing no traffic

If any vehicle detection is observed yellow LED (indicated mark) will glow, this has been shown using Fig. 8.



Fig.8 Yellow LED display

If the vehicle approaches towards in any bends then, the android display displays the notification alert as “has Moving Traffic”. The following android display shows that there is vehicle detection in all bends shown in Fig. 9.



Fig.9 Android display shows moving traffic

If there is any interrupt or the vehicle stood in between of ultrasonic transceiver and there is a no motion change of the vehicle for a certain period then Red LED (indicated mark) will glow, this has been shown using Fig. 10.



Fig.10 Red LED display

The following Fig. 11 android display shows that there are vehicles remained stationary for a long time in all bends. So, the android display displays the notification as “has heavy traffic”.



Fig.11 Android display shows heavy traffic

All these indications are provided with buzzer alarming and Wi-Fi android application displayed with the voice recognition simultaneously.

### IX. CONCLUSION

This project describes the prevention of accident due to the carelessness of the driver. This project will be the perfect substitute to the existing mirror setup arrangement. The replacement of mirror setup by the Ultrasonic sensor provides a better output as it is given to the microcontroller for further process. The programming code written in the controller is Arduino basic language which is compiled using the compiler. Through the Wi-Fi router, the signal is transmitted to the driver's android phone as a voice recognition message about the traffic and vehicle arrival on the other bend followed by LED indication and the Buzzer on the hairpin bends. This project also helps us to monitor the traffic from the control room without any GPS and GSM facility. Thus, we have successfully designed a prototype model which is fully secured from an accident, hence providing safe driving for the vehicle users.

### X. FUTURE SCOPE

Furthermore, this project can be extended by placing RFID tag on all vehicles and can place RFID reader in every hairpin ends especially in hilly areas. So that tracking of an individual vehicle can be made easier. With the help of GPS and GSM module, the navigation facility, as well as traffic information for the driver, can be provided effectively through the voice recognition. In order to increase the accuracy instead of Ultrasonic sensor, Radar sensor can be used and to increase the processing speed ARM processor replacing Arduino microcontroller. In order to perform multitask FPGA can be introduced with this system along with microcontroller.

### ACKNOWLEDGEMENT

We take this opportunity to gratefully acknowledge the Inspiration, encouragement, guidance, help and valuable Suggestions received from all our well-wishers.

We would like to thank our Project guide Prof. K.N.Thirukkuralakani, who have helped us and made available much useful information to complete this seminar project report. We also thankful to Prof. R.Veeraganesan and our Head of the Department Prof. Dr.B.Anand who has given valuable support for successful implementation of project seminar. Without their complete support and willing co-operation, this would not have been possible. We are forever obliged to our parents and friends for their encouragement to us and faith in our ability to succeed.

### REFERENCES

- [1] S.P. Bhumkar, V.V. Deotare and R.V. Babar, "Accident Avoidance and Detection on Highways," International Journal of Engineering Trends and Technology, vol. 3, Issue 2, 2012.
- [2] D. Haripriya, M. Puthanial and Dr. P. C. Kishore Raja, "Accident Prevention System and Security for Vehicles," International Journal of Computer Trends and Technology, vol. 12, no. 5, June 2014.
- [3] S.Uvaraja and V.Raghav Prashanth, "Advanced Pre-Warning System (Railways)," IACSIT International Journal of Engineering and Technology, vol. 4, no. 2, April 2012.
- [4] K.P. Sreevishakh, Prof.S.P. Dhanure, "Automotive Crash Insight using AMR Sensor System," International Journal of Advanced Research in Computer and Communication Engineering, vol. 4, Issue 5, May 2015.
- [5] Apeksha S. Chavan, Dipali D. Pansare, Swapnil P. Kadam, Naval K. Mayekar, Kavita V.Jha, Poonam R. Bhagwat, "Design of Accident Prevention System Using QRD 1114 and CNY 70 Sensors," International Journal of Emerging Technology and Advanced Engineering, ISSN 2250-2459, vol. 3, Issue 5, May 2013.
- [6] James K. Kuchar and Ann C. Drumm, "The Traffic Alert and Collision Avoidance System," Lincoln Laboratory Journal, vol.16, no. 2, 2007.
- [7] Chi Zhang, Hong Wang and Longrong Fu, "Automated Detection of Driver Fatigue Based on Entropy and Complexity Measures," IEEE transactions on Intelligent Transportation Systems, vol. 15, no. 1, February 2014.
- [8] Liang Qi, MengChu Zhou (Fellow, IEEE) and WenJing Luan, "Emergency Traffic-Light Control System Design for Intersections Subject to Accidents," IEEE transactions on Intelligent Transportation Systems, vol. 17, no. 1, January 2016.
- [9] Qiang Ji, Zhiwei Zhu and Peilin Lan, "Real-Time Nonintrusive Monitoring and Prediction of Driver Fatigue," IEEE transactions on Vehicular Technology, vol. 53, no. 4, July 2004.
- [10] Mohammad Ali, Paolo Falcone, Claes Olsson and Jonas Sjöberg, "Predictive Prevention of Loss of Vehicle Control for Roadway Departure Avoidance," IEEE transactions on Intelligent Transportation Systems, vol. 14, no. 1, March 2013.
- [11] S.Saranya, M.Shankar, N.Muthulingam, and T.Sakthivarman, "Intelligent Automobile System for Accident prevention and detection," International Conference on Engineering Trends and Science & Humanities (ICETSH-2015), ISSN: 2348 - 8549.
- [12] Seongjin Yim "Design of a Preview Controller for Vehicle Rollover Prevention," IEEE transactions on Vehicular Technology, vol. 60, no. 9, November 2011.
- [13] Zhe Wang and Mahub Hassan (Senior Member, IEEE), "Blind XOR: Low-Overhead Loss Recovery for Vehicular Safety Communications," IEEE transactions on Vehicular Technology, vol. 61, no. 1, January 2012.
- [14] Stefano Di Cairano (Member, IEEE), Hongtei Eric Tseng, Daniele Bernardini and Alberto Bemporad (Fellow, IEEE), "Vehicle Yaw Stability Control by Coordinated Active Front Steering and Differential Braking in the Tire Sideslip Angles Domain", IEEE transactions on Control Systems Technology, vol. 21, no. 4, July 2013
- [15] <https://data.gov.in/>
- [16] [https://www.google.co.in/url?sa=i&rc=t-j&q=&esrc=s&source=images&cd=&cad=rja&uact=8&ved=0ahUKEwjD\\_tnnuLDLahVG6WMKHDr4CaUQjRwIBw&url=http%3A%2F%2Fgooglet.com%2Fimages%2Findia%2520accidents%2520statistics&bvm=bv.116274245.d.cG&psig=AFQjCNHlvXXNjRTA2US5Tf1eD\\_nadwqIXQ&ust=1457504268813332](https://www.google.co.in/url?sa=i&rc=t-j&q=&esrc=s&source=images&cd=&cad=rja&uact=8&ved=0ahUKEwjD_tnnuLDLahVG6WMKHDr4CaUQjRwIBw&url=http%3A%2F%2Fgooglet.com%2Fimages%2Findia%2520accidents%2520statistics&bvm=bv.116274245.d.cG&psig=AFQjCNHlvXXNjRTA2US5Tf1eD_nadwqIXQ&ust=1457504268813332)