

# Implementation of Various MPPT Algorithms with Dc-Dc Converter for PV System

M. Valanraj Kumar, M. Mahakumar, M. Manojkumar, M. Hemaraj, E. Kumaravel

Department of Electrical and Electronics Engineering,  
Gnanamani College of Technology, Namakkal-637018, India

**Abstract-**This paper presents an implementation of Dc-Dc converter with a maximum power point tracking (MPPT) design for a photovoltaic (PV) system using a new optimization technique. The new optimization method which overcomes the limitations such as lower tracking efficiency, steady state oscillations, and transients as encountered in perturb and observe (P&O) and PSO techniques. The problem of tracking the global peak (GP) of a PV array under partial shading condition is attempted employing to improve MPPT technique. The proposed scheme is called as Grey Wolf Optimization, which used studied for a PV array under PSCs which exhibits multiple peaks and its tracking performance is compared with that of two MPPT algorithms, namely P&O-MPPT and PSO MPPT. The GWO MPPT algorithm implemented on a P-V system using MATLAB. Furthermore experimental setup is developed to verify the efficiency of the proposed system. From the obtained simulation and experimental results, it is observed that the proposed converter with MPPT algorithm outperforms both P&O and PSO MPPTs.

**Keywords:** Grey wolf optimization (GWO), maximum power point tracking (MPPT), partial shading conditions (PSCs), photovoltaic (PV).

## 1. INTRODUCTION

Various maximum power point tracking (MPPT) algorithms were discussed in literature [1-3] about the occurrence of mismatched non uniform isolation resulting in decrease in photovoltaic (PV) output power, the hot-spot generated damages the PV cells. Since the dynamics of the PV system under partial shading is time varying, MPPT design for PV power system should be equipped with features such as tracking global maximum power point (GMPP) at different conditions, e.g., shading, degradation of PV cell, and adaptability to PV characteristics change in PV array, smooth, and steady tracking behavior. There is number of MPPT techniques such as hill climbing (HC) [2], perturb and observe (P&O) [4][5], and incremental conductance (IC) [5] have been proposed for improving the efficiency of the PV system. The HC method uses a perturbation in the duty ratio of the power converter and the P&O method uses a perturbation in the operating voltage of the PV system [6]–[9]. Both these methods yield oscillations at maximum power point (MPP) owing to the

fact that the perturbation continuously changes in both directions to maintain the MPP resulting in power loss.

The two influencing parameters in P&O algorithm, namely perturbation rate and perturbation size, are discussed in [10]. To reduce these oscillations and improve the module efficiency, the IC method was proposed [11] which reduced the oscillations but not completely. Both P&O and IC methods fail during those time intervals characterized by changing atmospheric conditions [12], [13]. A few improved IC algorithms were also proposed to improve the MPP tracking capability during fast-changing irradiance level and load [14], [9]. To achieve a fast MPP tracking response, a simple trigonometric rule has been presented in [10] to establish relationship between the load line and I–V curve. A dynamic MPPT controller for PV systems under fast-varying insolation and PSCs is proposed in [15], which uses a scanning technique to determine the maximum power-delivering capacity of the panel at a given operating conditions.

Metaheuristic optimization methodologies such as particles swarm optimization (PSO) [12], and fire fly [16] have been extensively used for various engineering applications. Recently, Mirjalili et al. have developed a metaheuristic algorithm known as Grey Wolf Optimization (GWO). This algorithm is inspired by grey wolves to attack preys for hunting purpose. Further, several works are reported in literature on an alternative soft computing method known as grey wolf optimization which is attracting considerable interests from the research community compared to other optimization techniques because it is more robust and exhibits faster convergence. Furthermore, it requires fewer parameters for adjustment and less operators compared to other evolutionary approaches, which advantage when the rapid design process is considered. After a thorough literature survey, it is observed that GWO has not been exploited for designing an MPPT. Hence, this work attempts to exploit the GWO for designing an MPPT to obtain efficient tracking performance under PSCs [17-21].

This paper is organized as follows. Section II describes about the characteristics of the PV system under PSCs and the system description showing I–V and P–V curves of partially shaded modules. Section III describes the proposed GWO based MPPT algorithm to track the GP and Sections IV presents the simulation and experimental results. Then finally, conclusion is provided in Section V.

II.CHARACTERISTICS OF A PV SYSTEM UNDER PSCS

Basic Characteristics of a PV Cell

A PV cell can be represented by an equivalent single diode model [2]. D a diode connected in parallel to the current source; Rs the sum of resistances due to all the components that come in path of current which is desirable to be as low as possible; Rp to represent the leakage across the P-N junction which is desirable to be as high as possible; I difference between the photocurrent Ipv and the diode current ID, which is given by,

$$I = I_{pv} - I_0 [\exp(qV + qR_s I / N_s K_s T a - 1)] - V + R_s I / R_p (1)$$

where I0 is the saturation current, a is diode ideality factor, ks is Boltzmann's constant, q is charge of an electron, T is temperature in kelvin, and Ns is the number of cells in series.

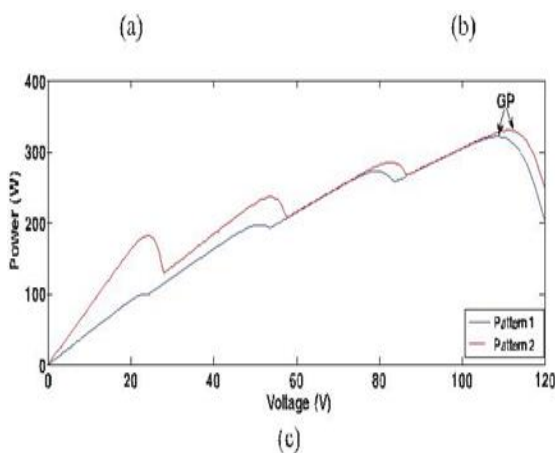
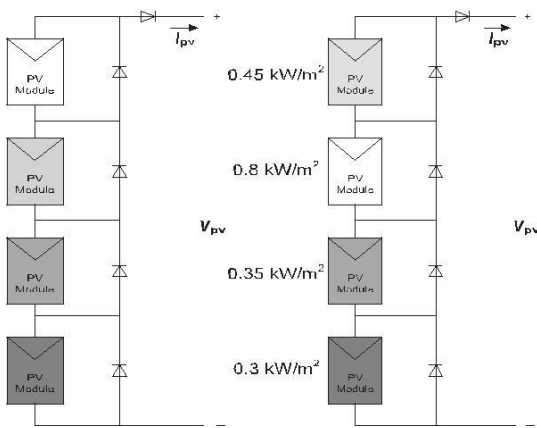

Fig.1.4S configuration under different shading patterns. (a)Pattern 1.(b) Pattern 2. (c) P–V curves under PSCs.

System Description

A PV array consists of several PV modules connected in series to produce a higher voltage and in parallel to increase the current. During PSCs, multiple peaks, i.e., local and global maxima points are observed in the P–V characteristics curve due to the presence of bypass diodes. The two different PV arrays are considered in this work and are shown in Figs. 1 and 2A configuration consisting of four modules in series

(4Sconfiguration) having two different shading patterns with their P–V curves is shown in Fig. 1. The second PV configuration that has two series modules connected in parallel with another two series modules (2S2P configuration) having two different shading patterns with their respective P–V curves are shown in Fig. 2.

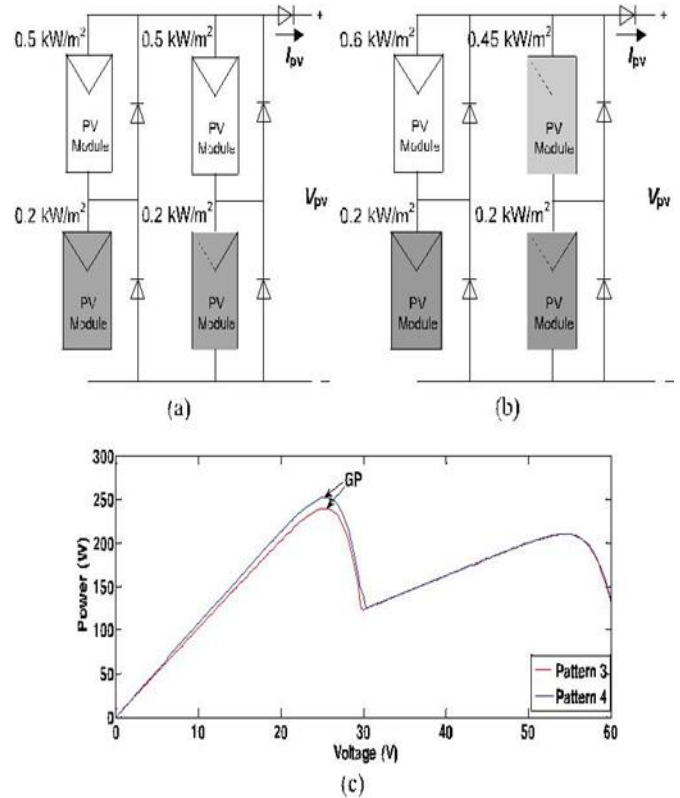

Fig.2. 2S2P configuration under different shading patterns. (a) Pattern 3.(b) Pattern 4. (c) P–V curves under PSCs.

III. GWO AND ITS APPLICATION IN MPPT DESIGN

The GWO algorithm imitates the leadership hierarchy and hunting mechanism of grey wolves in nature proposed by Mirjalili et al. [14]. Grey wolves are considered to be at the top of food chain and they prefer to live in a pack. Four types of grey wolves such as alpha(α), beta(β), delta(δ), and omega(ω) are employed for simulating the leadership hierarchy.

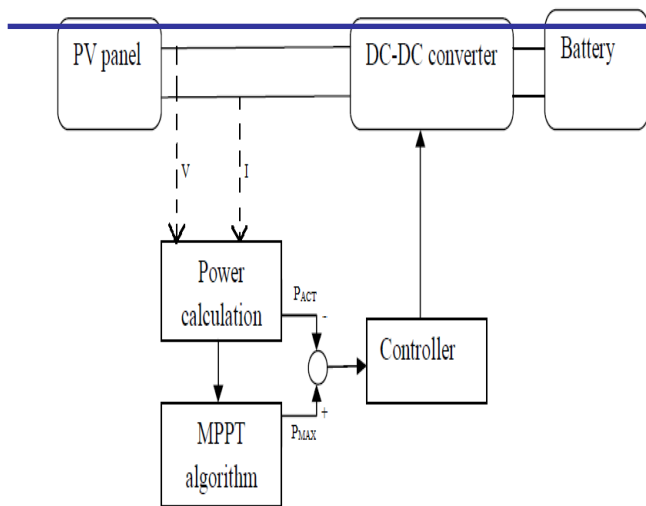

Fig.3.Block diagram

In order to mathematically model the social hierarchy of wolves while designing, GWO we consider the fittest solutions as the alpha. Consequently, the second and third best solutions are named as the beta and delta respectively. The rest of the candidate solutions are assumed to omega. fig 3 shows three main steps GWO algorithm, namely hunting, chasing and tracking prey, and attacking prey which are implemented to design GWO optimization. Grey wolves encircling behavior can be modelled by the following equations

$$D=|C \cdot X_p(t) - X_p(t)| \quad (2)$$

$$X(t+1)=X_p(t) - A \cdot D \quad (3)$$

t-current iteration, D, A and C- coefficient vectors, Xp-position vector of prey, X-position vector of grey wolf

$$A=2a \cdot r1 - a \quad (4)$$

$$C=2 \cdot r2 \quad (5)$$

a-linearly decreases from 2 to 0, r1, r2-random vectors

**Application of GWO for MPPT Tracking**

Fig.4 shows the block diagram of the proposed MPPT scheme for the PV system. For number of grey wolves, i.e., duty ratios, the controller measures  $V_{pv}$  and  $I_{pv}$  through sensors and computes the output power. The flowchart of the proposed GWO-based MPPT algorithm shown in fig 5. During partial shading, the P-V curve is categorized by multiple peaks having various local peaks(LPs) and one GP.It is to note that when the wolves find the MPP, their correlated coefficient vectors become nearly equal to zero.

In the proposed method, an attempt has been made to combine GWO with direct duty-cycle control ,i.e ,at the MPP duty cycle is sustained at a constant value which is turn reduces the steady-state oscillations that exist in conventional MPPT techniques and lastly, the power loss due to oscillations is reduced resulting in higher system efficiency. Therefore (3) can be modified as follows

Thus the fitness function of the GWO algorithm is formulated as

$$P(d_i^k) > P(d_i^{k-1}) \quad (7)$$

Where p represents power, d is duty cycle,I is the number current grey wolves, and k is the number of iterations.

**IV.RESULTS AND DISCUSSION**

**Simulation Results:**To evaluate the performance of the proposed GWO based metaheuristic. MPPT algorithm, its performance were compared with P&O and PSO MPPT algorithms. All the above three algorithms were implemented under PSCs and rapidly changing insolation level for both 4S and 2S2P configurations.

The power, voltage, and current for configurations with PSCs employing GWO,PSO and the second pattern appears for next 0.1s.In pattern 1 is made to exist for first 0.1 s and the second pattern appears for next 0.1s.

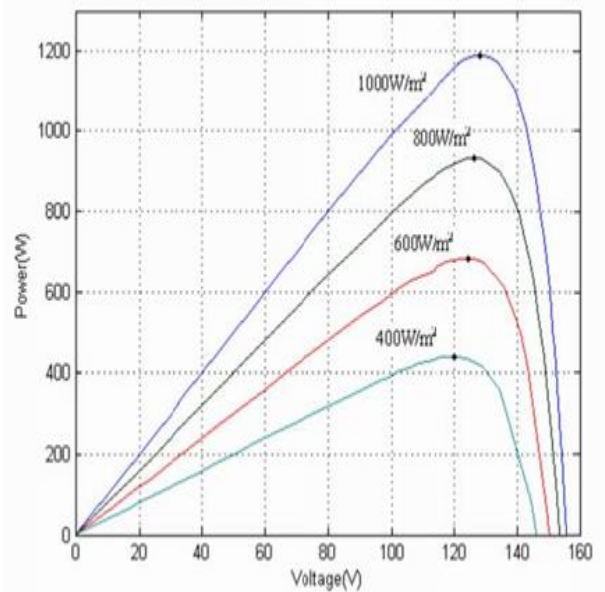

Fig.4.PVcurveofsolararrayfordifferentirradiationandconstante mperatureof25`C

i.e, the operating point oscillates around the MPP gives rise to power loss and also results in slowing down the speed of response of the algorithm and reduces the efficiency of the PV system. The simulation is now repeated for 2S2P configuration is having two major different patterns, namely patterns 3 and 4. The GWO based MPPT GP reaches 239.1 W, PSO tracks GP mostly as it tracks the peak which comes in contact first, i.e., it may be a GP or LP resulting in oscillations around MPP. All the above findings are implemented for existence of pattern 3 which appears for 0.1s. for pattern 4,the GWO-based on the MPPT locates the GP of 251.6W,PSO locates GP at 251.5w,and P&O gets settled to the GP of 247W as before in pattern 3 resulting in oscillations around the MPP. The tracking curves are shown in fig.7.

The simulation results presented in figs.6 and 7 envisage that the GWO-based MPPT can handle partial shading efficiently

and it outperforms both P&O and PSO with respect to faster convergence to GP, tracking speed, reduced steady state oscillations, and higher tracking efficiency. The simulation results presented in figs 6 and 7 are briefly summarized in Tables I and III. The MPPT tracking efficiency is calculated as the ratio between average output power obtained at steady state and maximum available power of the PV array under certain shading pattern [13].

Furthermore a qualitative comparison among various fast converging MPPT methods is presented in Table II. From Tables III and I, it is seen that the GWO based MPPT outperforms over the other two MPPT methods. To ensure the effectiveness of the proposed MPPT algorithm, different loads such as an RL load (50Ω, 15mH) are connected in place of resistive load and are studied for pattern 1.

Fig.5.Flow chart

Experimental Results

To validate the effectiveness of the proposed GWO based MPPT, experiments were carried out on real PV array for both 4S and 2S2P configurations. The Processor running at 250 MHz and a slave DSP subsystem based on TMS320F240 DSP and Hall effect sensor is used to sense the voltage and current of the PV array before sending it to the controller. Fig.9 shows the experimental setup of the system. New MPP from the new PV curve. The tracking curves of GWO and PSO based MPPT reach GP of 143.5W, whereas P&O gets trapped to LP of 65.32W. In order to validate the effectiveness of the proposed MPPT for a different random pattern, experiments were carried out for 2S2P configurations having two types of shading and pattern 7 having GP of 77.98W and LP of 47W and pattern 8 are having the GP of 58.25W, respectively. The experimentally determined MPPT curves employing with the proposed and existing methods. The tracking curves of the proposed GWO and PSO MPPT are able to converge to GP of 77.98W and P&O by chance settles to the GP resulting in oscillations. After sometimes when the shading pattern changes to a new P-V curve marked as pattern 8, once again the three algorithms search the PV curve for a new MPP. The curves of the proposed MPPT and PSO based MPPT converge of the GP of 58.25W and P&O gets trapped at a local optimum value of 46.64W.

To verify that the effectiveness of the proposed MPPT algorithm is working accurately under RL load, experiments were carried out for pattern 5. Fig. 6 shows that the settling time increases, but the performance of the proposed MPPT remains the same for convergence toward the GP.

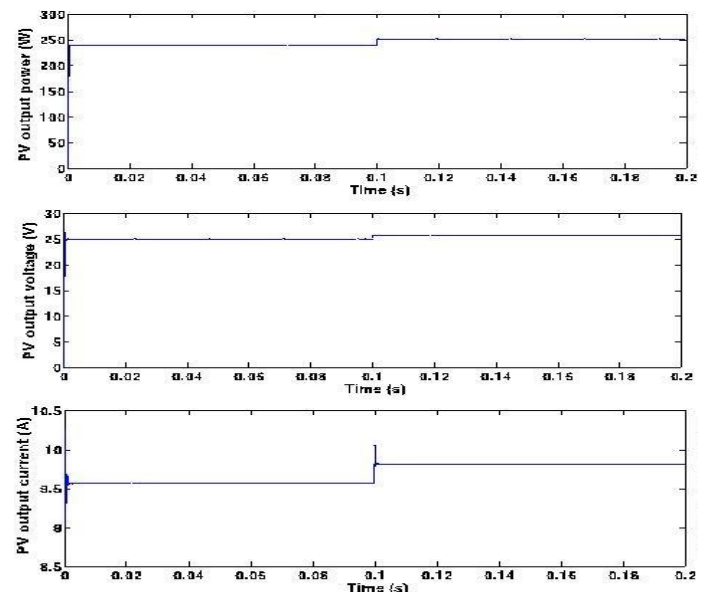
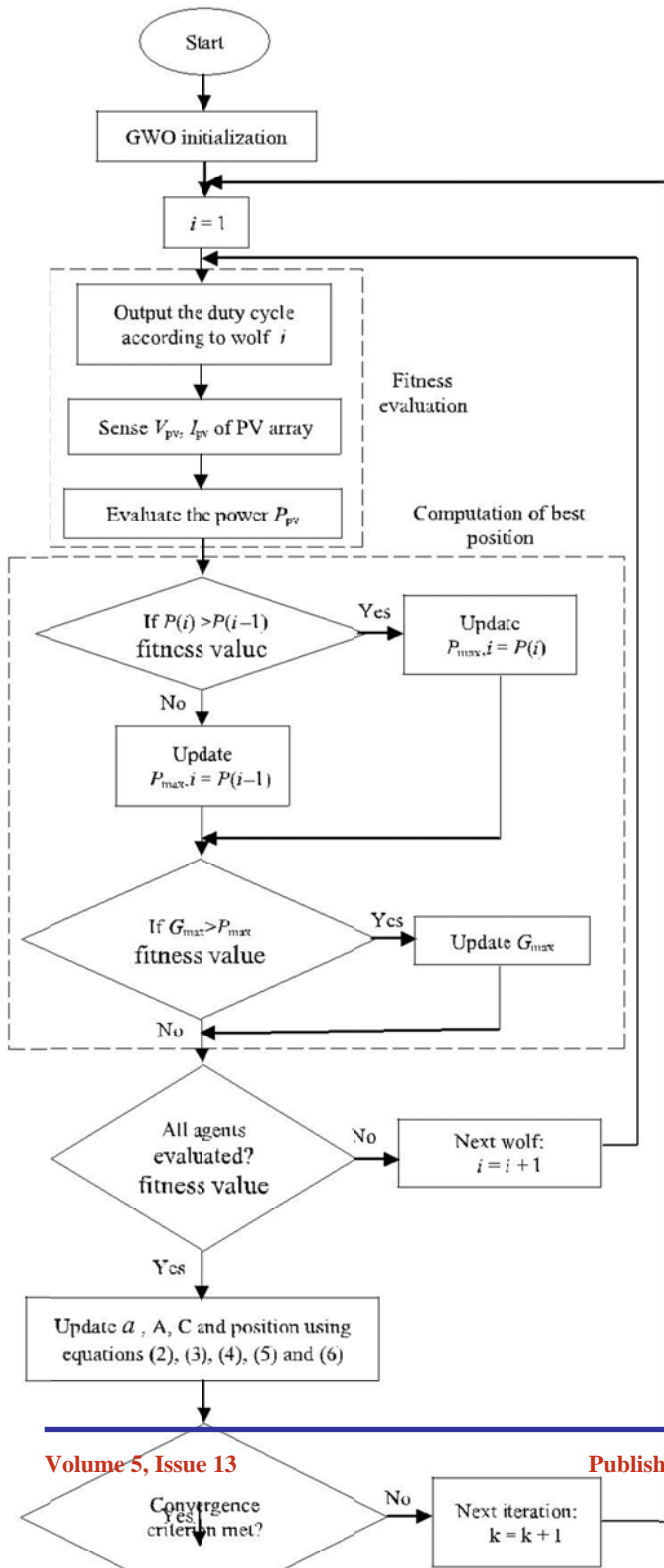

Fig.6. GWO-based MPPT.

Table:Performancecomparison of proposed MPPT method

Shading pattern	Maximum power from P-I curve (W)	Tracking techniques	Maximum power (W)	Maximum voltage (V)	Maximum current (A)	%Tracking efficiency
3	239.3	P&O	234	24	9.75	97.78
		IPSO	239.05	25	9.562	99.89
		GWO	239.1	25.01	9.56	99.91
4	251.8	P&O	247	23.9	10.3	98.09
		IPSO	251.5	25.64	9.808	99.88
		GWO	251.6	25.64	9.812	99.92

The proposed method can used successfully detect the shading pattern in variations and re initialize the MPPT process exhibiting superior of the performance in terms of faster convergence to that of GP, reduced steady-state oscillations, and faster tracking in PV system under PSCs.

**V.CONCLUSION:**

This paper proposed a new approach is called grey wolf optimization to design a maximum power extraction algorithm for PV systems to work under PSCs condition. In these view of assessing the effectiveness of this new MPPT (grey wolf based MPPT), its performance was compared with two existing MPPTs, namely P&O and PSO based MPPT methods and from the obtained results, it was found that the GWO based MPPT exhibits superior performance compared to other two MPPTs

**REFERENCES**

[1] H.Patel and V.Agarwal, "Maximum power point tracking scheme forPV systems operating under partially shaded conditions," IEEE Trans.Ind. Electron.,vol.55,no.4,pp.302 to 310,Apr.2008.

[2] B.Subudhi and R. Pradhan,"A comparative study on maximum powerpoint tracking techniques for photovoltaic power systems,"IEEE Trans. Sustain.Energy,vol.4,no.1,pp.89-98,Jan.2013.

[3] M.Valan Rajkumar, P.S.Manoharan, Modeling and Simulation of Three-phase DCMLI using SVPWM for Photovoltaic System, Springer Lecture Notes in Electrical Engineering, under the volume titled "Power Electronics & Renewable Energy Systems", Volume 326, Chapter No 5, January 2015, Pages 39-45.

[4] M.Valan Rajkumar, P.S.Manoharan, Harmonic Reduction of Fuzzy PI Controller based Three-Phase Seven-level DCMLI with SVPWM for Grid Connected Photovoltaic System, Journal International Review on Modeling and Simulations, Volume 6, No 3, June 2013, Pages 684-692.

[5] M.A.Elgendy, B.Zahawi, and D.J.Atkinson, "Assessment of perturband observe MPPT algorithm implementation techniques for PV pumpingapplications," IEEE Trans. Sustain. Energy, vol. 3, no.1, pp.21-31,Jan.2012.

[6] M.A.Elgendy,B.Zahawi, and D. J. Atkinson, "Operating characteristicsof the P&O algorithm at high perturbation frequencies for standalone PVsystems," IEEE Trans. Energy Convers., vol. 30, no. 1, pp. 189-198, Jun.2015.

[7] M.Valan Rajkumar, P.S.Manoharan, FPGA Based Multilevel Cascaded Inverters with SVPWM Algorithm for Photovoltaic system, Elsevier Journal Solar Energy, Volume 87, Issue 1, January 2013, Pages 229-245.

[8] R. Kotti andW. Shireen, "EfficientMPPT control for PV systems adaptive to fast changing irradiation and partial shading conditions," Solar Energy, vol.114, pp.397-407, Mar. 2015.

[9] K. Ishaque, Z. Salam, M. Amjad, and S. Mekhilef, "An improved particle swarm optimization (PSO)-based MPPT for PV with reduced steady-state oscillation," IEEE Trans. Power Electron., vol. 27, no. 8,pp. 3627 to 3638, Aug. 2012.

[10] P.Thirumurugan, P.S.Manoharan, M.Valan Rajkumar, "VLSI Based Space Vector Pulse Width Modulation Switching Control in the proceedings of IEEE International Conference on Advanced Communication Control and Computing Technologies ICACCCT 2012 on August 2012, ISBN No. 978-1-4673-2045-0 (Print) (Page):366-370.

[11] M.Valan Rajkumar, P.S.Manoharan, Space Vector Pulse Width Modulation of Three-Phase DCMLI with Neuro-Fuzzy MPPT for Photovoltaic System, World Journal of Modelling and Simulation, Volume 10, No 3, August 2014, Pages 193-205.

[12] Tan C.S.,Baharuddin I. "Study of Fuzzy And PI Controller for permanent magnet brushless dc motor drive". Proceedings of international power Engineering and Optimization Conference, June, 23-24,2010,pp.517-521.

[13] Rajkumar, M.V., Prakasam, P. and Manoharan, P.S. (2016) Investigational Validation of PV Based DCMLI Using Simplified SVM Algorithm Utilizing FPGA Tied with Independent Sources. Circuits and Systems, 7, 3831-3848. <http://dx.doi.org/10.4236/cs.2016.711320>

[14] Bhat,A.K.S.,1994. Analysis and Design of LCL- Type Series Resonant Converter ,IEEE Trans Power Electronics,8:1-11.

[15] K.S.Tey and S. Mekhilef, "Modified incremental conductance MPPT algorithm to mitigate inaccurate responses under fast changing solar irradiation level," Solar Energy, vol. 101, pp. 333 to 342, Jan. 2014.

[16] Math Works,2001,Introduction to MATLAB, the Math Works,Inc.

[17] M.Valan Rajkumar, P.S.Manoharan, "Modeling, Simulation and Harmonic Reduction of Three-Phase Multilevel Cascaded Inverters with SVPWM for Photovoltaic System", Journal International Review on Modeling and Simulations, Volume 6, No. 2, April 2013, Pages 342-350. ISSN: 1974-9821 (Print), 1974-982X (Online)

[18] M.Valan Rajkumar, P.S.Manoharan, "Modeling and Simulation of Five-level Five-phase Voltage Source Inverter for Photovoltaic Systems", Journal Przegląd Elektrotechniczny, Volume 10, No. 10, October 2013, Pages 237-241. ISSN: 0033-2097 (Print)

[19] A.Ravi, P.S.Manoharan, M.Valan Rajkumar, "Harmonic Reduction of Three-Phase Multilevel Inverter for Grid connected Photovoltaic System using Closed Loop Switching Control", Journal-IREMOS, Volume 5, No 5, October 2012, Pages 1934-1942. ISSN: 1974-9821 (Print), 1974-982X (Online)

[20] P.Thirumurugan, P.S.Manoharan, M.Valan Rajkumar, "VLSI Based Inverter Switching Control" in the proceedings of International Conference on Mathematical Modeling and Applied Soft Computing MMASC'12 - Coimbatore Institute of Technology on July 2012, Vol-2 (Page):965-973.

[21] S. Mirjalili, S. M. Mirjalili, and A. Lewis, "Grey wolf optimizer," Adv.Eng. Software, vol. 69, pp. 46-61, 2014.