

Hybrid Power Generation System using Solar and Wind Energy

K. Balaji

Assistant Professor
Department Of Mechanical
Vemu Institute Of Technology
P. Kothakota - 517112

B. Mohan Krishna, S. Prathap,

K. N. Lokesh Chandra
Ug Students
Department Of Mechanical
Vemu Institute Of Technology
P. Kothakota - 517112

Abstract— This paper proposes a hybrid power generation system using Solar and Wind energy. It is fact that energy is an important resource for any country in the world to develop economically strong in all aspects. Without energy one cannot sustain the life such as transportation from one place to another, home needs, industrial purposes etc., More than 80% world energy consumption is produced by using fossil fuels it is estimated that the fossil fuel reserves will end by 2250. However this technology is already existed in two different forms, but we are giving the two technologies in one place. Most probably concentrating on the wind turbine blade design by using readily available PVC (Poly Vinyl Chloride) pipes. It is easy to get them into required size and shape by following design considerations. It is household usage purpose project which is available at low cost compared to individuals available. The reason behind combining both of them is to improve the pole efficiency for the same using in conventional methods.

Keywords— Solar Panel, DC Generator, Voltage Regulator, And Anemometer.

I. INTRODUCTION

Energy is most essential part of modern life. We use many technologies for the production of power. The common non-renewable sources we use for the production of power are coal, natural gas and oil. Since many decays we have been using these for our several needs. Fossil fuels are formed by anaerobic decomposition of buried dead organisms over 650 million years ago. Among these fuels oil has high density of energy. World needs 8, 40, 00,000 barrels of oil per day. We use 16, 76,120 metric tonnes of coal every day. We utilize 2,963 Cubic meters of Natural gas every day. By the above data we can estimate how much amount of fuel we are utilizing each day to meet our requirements. Using of fossil fuels is not a modern thing, for the period of our ancestors we are using fuels for the purpose of cooking, lighting and other purposes. In today's environment we are using fuels for the working of machineries in industries, transportation and to produce electric power. After World War-2 the demand for fossil fuels had increased rapidly due to industrial revolution. The energy consumption is increasing at a rate of 2.3% every year. The below graph represents the production of fuels from the past 200 years to future prediction for 200 years.

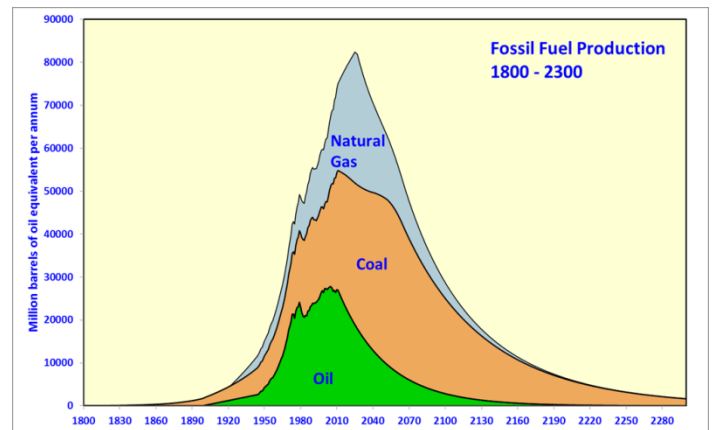

Fig: 1.1. Fossil Fuel Production from 1800 to 2300 A.D.

It is known that the world fuel consumption rates are increasing by 2.34% every year. If present trend continues the world in the year 2000 A.D. will be more crowded than that of today. The world Population may reach 7 billion by 2000 A.D. The conventional sources of energy are depleting and may be exhausted by the end of the century or beginning of the next century. Nuclear energy requires skilled technicians and poses the safety as regards to radioactive waste disposal. Solar energy and other non-conventional energy sources, those are to be utilized in future.

I.I RENEWABLE ENERGY SOURCES

Renewable energy sources are the sources which can be reproduced or Energy that can be replenished at the same rate as it is used. While fossil fuels will be the main fuels for thermal power, there is a fear that they will get exhausted eventually in the next century. Therefore other systems based on non-conventional and renewable sources are being tried by many countries. These are solar, wind, sea, geothermal and biomass. These are also called alternate energy sources or natural or new energy sources but the term renewable has gained the most widespread acceptance.

We are using both renewable and non-renewable energy sources with a common aim of production of electrical power or energy. We use this energy to rotate the shaft of the turbine either by steam or wind and the rotational output of shaft is given as the mechanical input to the shaft of generator using coupling. The generator produces electricity by movement of conductors in a magnetic field.

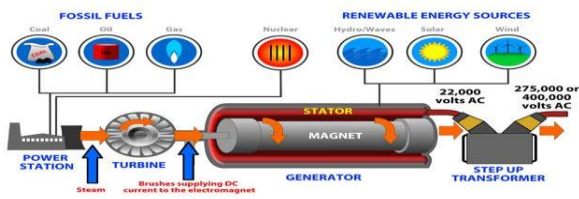

Fig. 1.2 Usage of different energies for the production of electricity.

II PROBLEM DEFINATION

The demand for the energy is increasing day by day but the production or supply is not meeting our demand at a reasonable cost. We cannot avoid the usage of electrical power for our requirements in this modern world. We are having renewable energy sources in which solar and wind energy has higher potential in availability. Every country needs to produce power to their requirements using resources. The installation of either windmill or a solar farm is high investment. Solar energy is unavailable in night time and low sunny days. This makes common man not to install solar farm. The wind mill requires continuous flow of wind breeze to produce continuous power, due to seasonal winds there is no continuous wind breeze so it produces discontinuous outputs. This makes people not to install the windmill.

III OBJECTIVE OF PROJECT

The objective of the project is to

1. To Increase the usage of renewable energy sources.
2. To reduce the usage of fossil fuels.
3. To improve the living conditions of mankind.
4. To protect environment from pollution.
5. To utilize land and material optimally.

IV. THE PROPOSED HYBRID POWER GENERATION SYSTEM USING SOLAR AND WIND ENERGY PROPOSED SYSTEM

- By combining the advantages of both wind and solar power to meet our requirements.
- The SMART POLES can be used for continuous supply of energy from the system. The word “data” is plural, not singular.
- The system consists of both windmill and solar panels integrated to one structure.
- So that it utilizes both the systems at one place and gives combined output.

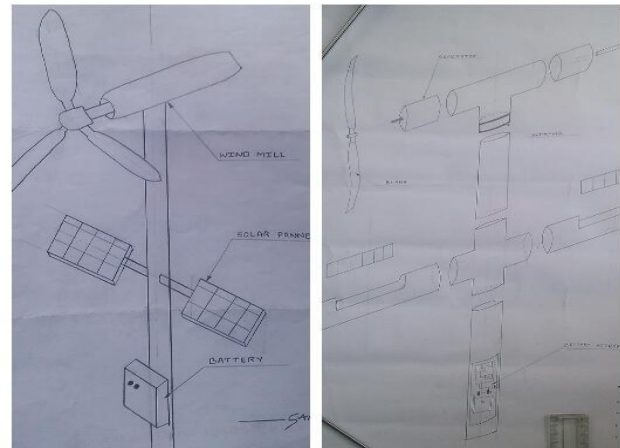

Fig.4.1. Basic View of Smart Poles

IV. I DESIGN

The basic design is developed using AutoCAD software.

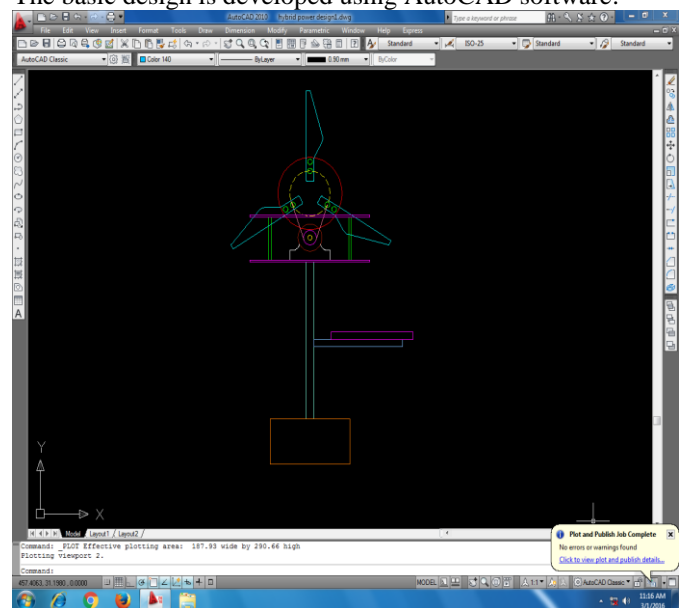

Fig. 4.2. Design of SMARTPOLE in AutoCAD.

1. The system consists of Arms in which PV cells are placed.
2. The head part consists of the wind mill or wind turbine generator which converts wind energy into electricity by the rotation of shaft of generator. The bottom part consists a housing in which electricity produced is converted and stored.
3. The head part consists vane which orients the windmill blade to the direction of wind for better performance.

IV. II DESIGN OF WIND BLADES

For this project we designed the wind blades uniquely with the readily available material like PVC (Poly Vinyl Chloride) pipe of diameter 11.5 cm and we cut the same in to the required shape of three feet size choose for our requirement by following the principles of aerodynamics. Theoretical maximum efficiency of the wind turbine is given as follows

$$P = \frac{1}{2} \rho A V^3$$

Where, ρ = Air density
 A = Swept area
 V = Air velocity

But whereas actual results are slightly differ from the practical results. By using the above given theoretical formula we can able to find out the theoretical efficiency of any designed wind turbine.

PRACTICAL EFFICIENCY

In actual practice based on rotor design the efficiency may depends. The factors that results in reduced efficiency are such as

Tip losses, Wake effects. Drive train (Shaft connected to generator) efficiency losses, Blade shape losses.



Fig:4.3 Horizontal axis wind turbine.

In this project we have used the HAWT (Horizontal Axis wind Turbine). Which is convenient for many geographical locations to obtain much power from the wind when compared to other axis turbines. Since we have many designs emerged so far yet there is completely developed blade design and not yet maximum efficiency is achieved .

HAWT BLADE DESIGN

A focus in made on design of wind turbine with the horizontal axis. It is very complicated to design its profile anyway we tried our best to give the best out of it .

Tip speed ratio:

It is defined as the relationship between rotor blade velocity and relative wind velocity.

$$\lambda = \Omega r / V_w$$

Where,

λ = Tip speed ratio

Ω = Rotational velocity (rad/s)

r = radius

V_w = wind speed.

BLADE PLAN SHAPE:

$$C_{opt} = \frac{2\pi r}{n} \frac{8}{9C_l} \frac{U_{inf}}{\lambda V_r} \text{ where } V_r = \sqrt{V_w^2 + U^2}$$

r = radius (m)
 n = Blade quantity
 C_l = Lift coefficient
 λ = Local tip speed ratio
 V_r = Local resultant air velocity (m/s)
 U = wind speed (m/s)
 U_{inf} = Design windspeed (m/s)
 C_{opt} = Optimum chord length

Figure 2. A typical blade plan and region classification.

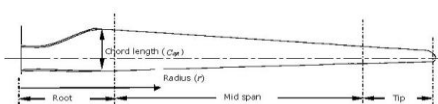

Fig: 4.4 Blade plan

**V. IMPLEMENTATION
 BASIC COMPONENTS**

- Wind Turbine.
- Generator.
- Solar PV Cells.
- Protection circuit.
- Charge flow controller.
- Battery storage.
- Assembly structure.

METHODS FOLLOWED:

1. Grinding of blade to get the required shape after marking dimensions.
2. Grinding of circular metal disc to obtain uniform shape.
3. Fixing of blades to the circular disc
4. Drilling of holes on the circular disc to fix the blades each at 120 degrees

**5. DISCHARGING OF A BATTERY FOR CHARGING.
 BLOCK DIAGRAM OF HYBRID POWER GENERATION SYSTEM:**

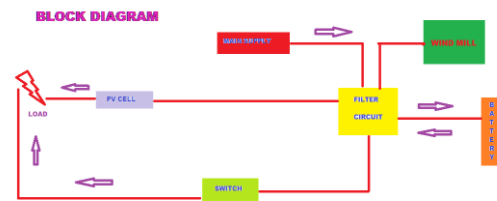

Fig: 5.2.d. Block Diagram

The block diagram for the smart pole setup is shown in above figure.

The block diagram represents the function of smart pole. It consists the flow of energy from one component to other component in a systematic way. The top portion consists of main supply in case of emergency, and wind mill. The energy from PV cell and windmill are connected to filter circuit the filter circuit send the energy to the battery for storage. Again the energy is taken by load whenever switch is activated. The arrow directions indicate the flow of charge in the circuit.

CIRCUIT DIAGRAM

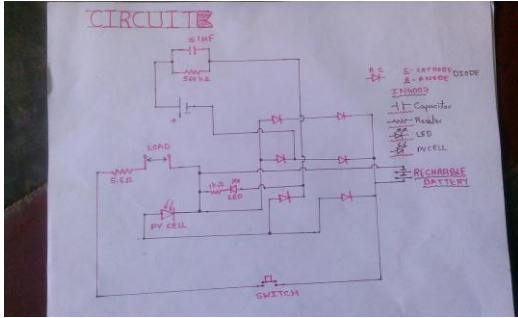

Fig.5.2.e: Circuit Diagram for smart poles

The Electronic Components used in the circuit are
 Capacitor.
 Resistor.
 LED-Light Emitting Diode/
 PV Cell.
 Switch.
 Rechargeable Battery.
 Generator.

VI TESTING

6.1 SOLAR OUTPUT

Testing have been conducted for different connections for output and the results are as follows

S.No	Time (Clock in hrs)	Temp (Degree Celsius)	Voltage(volts)	Ampere(Amps)
1	09.00	29	17.7	3.3
2	12.00	33	19.5	3.8
3	03.00	31	18.7	3.7

Table: 6.1.a. output from Photo Voltaic cell

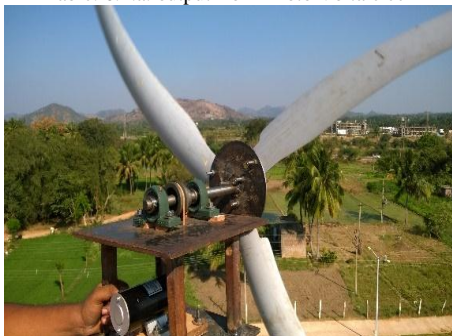

Fig 6.2.a: Testing of wind turbine

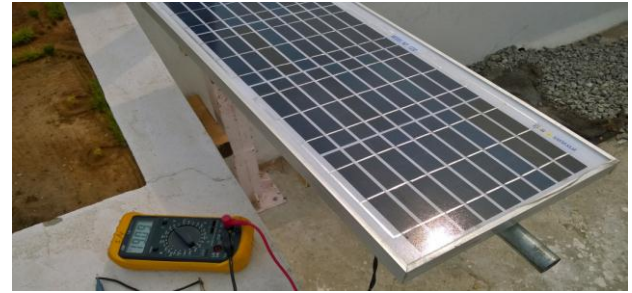

Fig 6.1.a: Solar panel output checking with multimeter

6.2 WINDMILL OUTPUT

The output of windmill is varied due to difference in velocity of wind and swept volume of wind by rotor diameter.

Test with rotor diameter of 15 mm

S.NO	Wind velocity (km/h)	Blade shaft speed (rpm)	Generator shaft speed (rpm)	Voltage (v)	Ampere (A)
1	12	63	252	12.02	2.84
2	15	75	350	14.5	3.1

Table 6.2.a Output from wind turbine

VIII CONCLUSION

As the usage of fossil fuels are increasing day by day it has an adverse effects on environment, it also increases the depletion of fossil fuels. We will see a world without fossil fuel in future. Without the energy sources we cannot generate electricity. So we have to depend extensively on renewable energy sources and make use of them to a larger extent.

So by this system of smart poles we can increase the utilization of wind and solar power. After the required advancements of the system these can replace the existing energysystems.

VII ADVANTAGES

- Regeneratable.
- Nonpolluting.
- Continuous supply of power.
- High returns of investments.
- Reduced investments of the system for same output of two sources.

IX REFERENCES

1. www.windpower.org
2. www.arcc.ou.edu
3. www.scribd.com
4. www.scribd.com