

# Human Body Temperature based Air Conditioning Control System

<sup>1</sup>Akogbe A. Michael, <sup>2</sup>Folorunso Taliha Abiodun, <sup>3</sup>Olaniyi Olayemi Mikail, <sup>4</sup>Aliyu Ibrahim

Department of Computer Engineering  
Federal University of Technology  
Minna, Nigeria

**Abstract**—Air Conditioners and air conditioning systems are integral part of almost every building and they contribute a significant part of the total energy consumption. In Nigeria, heating and cooling appliances accounts for about 44% of utility bills. With exponential increase in the use of cooling devices, there is a simultaneous increase in the electrical power consumption and occurrence of health issues, such as building-related symptoms and sick building syndromes due to air conditioners. Hence, there is a need to fathom other ways of operating the air conditioning systems in other to minimize the energy consumption and other health related issues. In view of this, we have applied a Novel control method to regulate the operation of the air conditioning systems in offices and single rooms, based on the occupant's or resident thermal comfort as against the traditional method based on the indoor temperature. The control signal is based on the occupant's body temperature which is obtained via sensors on a table within the office or room. This information is sent to a microcontroller (AT89C52) where it is compared with a reference temperature and the air-conditioner is regulated accordingly. The system was evaluated using the body temperature of many people either "with normal" or "above normal" thermal states. The result of the evaluation shows that the system's response is faster in temperature regulation when used for subjects with body temperature "above normal" thermal state. Furthermore, the operational time of the new method is significantly less than that of the old (traditional) method which definitely accounts for the reduction in the total energy consumption.

**Keywords**—Microcontroller, Air Conditioner, Thermal comfort; Control strategy, Energy consumption.

## I. INTRODUCTION

Advancement in technology has caused tremendous increase in desires for modern facilities, leading to increasing needs of certain electrical appliances like Air Conditioners (A/C), to provide comfort at homes and in offices. Air-conditioners (A/C) in offices and homes provides conducive and comfortable environment for the occupants, for which the indoor thermal properties are regulated [1]. It has been observed that temperature control set-points other than a value that offers thermal comfort of occupants of Air Conditioned space do subject A/Cs to higher energy waste in addition to occupant's dissatisfaction in thermal comfort. A degree Celsius drift of such set-points towards thermal comfort fostered temperature can provide 6 % savings in energy consumption as pointed out in [2]. The challenge

arising from the use of an A/C is therefore associated with limitation in its control switching methods. There have been attempts in recent times, to develop reference temperature such that thermal comfort conditions are attained based on conditions been modeled around occupant's adaptable behaviors in the aspects of clothing, metabolic rate of activities, hunger and anxiety among other factors. These have become pertinent because the degree of satisfaction obtainable by occupants from air conditioned space can affect their productivity and health [2]. Traditionally, A/Cs had been regulated in a way, in other to ensure that the temperature of a room or an apartment is maintained at a particular level, relatively to the ambient temperature of the environment. Most A/C control systems are based on this traditional strategy in which readings of a sensor of the ambient temperature of the environment and a desired temperature set-point by occupants are used to regulate the A/C, producing cool air depending on these set parameters. One challenge of this control strategy is that it regulates temperature about a desired temperature set-point that does not take thermal comfort of occupants into consideration. Another challenge is in higher energy consumption to attain set-point temperature in wider temperature controlled space (apartment), making size of apartments as a determinant factor of energy consumption. Research has shown that huge amount of energy is been expended and wasted in many homes and offices across the globe in operation of appliances such as A/C due to the fact that it might remain in operation whether the occupant is inside the apartment or not. It is estimated that about 40% of the supplied energy is being wasted in Nigeria due to misuse of appliances such as A/C whereas about 60% of Nigerian populace are without electricity [3].

In view of the above, we have proposed the use of an automatic control system for a single resident apartment that is different from the traditional control system, the proposed design makes use of residents body temperature as control variable of the control method instead of manual set-point temperature value, thus ensuring the thermal comfort of the resident at all time. This technique also ensures that the A/C works by the dictates of thermal condition of occupant, thereby making the A/C operational only at instances when it is needed to satisfy the resident's temperature requirement, thereby eliminating any excessive operation and waste of energy.

The remaining part of this paper is divided into the following sections: A review of past and related works on the subject matter in Section II while section III focuses on the control strategy adopted and its comparison with the conventional one. In section IV, the proposed methodology of the design is presented and the results obtained are presented in section V. Section VI presents the conclusion and suggestions for future works.

## II. RELATED WORKS

In quest for effective and improved operation of A/C, especially in energy consumption, various works have been carried out by various researchers, leading to couples of proposed techniques. A related work of Kwok et al [4], carried out detailed and broad survey with the intension of developing a new notion for Adaptive Comfort Temperature (ACT) in buildings. In that work, an adaptive relationship between the indoor comfort temperature and the outdoor temperature was determined in order to model the indoor temperature as a function of the outdoor temperature. The ACT algorithm though optimizes energy consumption and provides acceptable thermal comfort in the cooling space, only serves large commercial or public applications. It is not based on residents' or occupants' temperature but the environmental condition.

Sanjit K. et al [5], proposed an improvement on the operation of conventional control method of the A/C by using fuzzy logic technique. The control parameters of the A/C were fuzzified for its fuzzy controller in order to reduce electric energy consumption of its compressor. In a related work in [6], infrared sensor was used to detect body location and body temperature of resident to ensure that the system is operated maximally. However these systems were not cost effective.

Another related work [7] studied the relationship between changes in temperature of cooling space and the human body. The study reveals that the skin temperature of the human body returns to normal after a period of operation of the A/C, hence its continuous operation could lead to discomfort and wastage of energy.

New control method of air-conditioning systems in offices was proposed [8]. The human psychological reaction through a new signal transfer technique using the signals sent from human body were applied in that work to control the room's temperature so that the resident's actual requirement is satisfied.

We have applied the use of the wrist skin temperature as the parameter to control the A/C system in this work, due to the fact that the wrist remains the only physical and accessible part of the human body that reflects the real thermal comfort [8].

## III. ADOPTED CONTROL STRATEGIES

In this section, we reviewed the traditional control strategy currently adopted for A/C control as shown in Fig. 1

in order to highlight its short comings and discuss the new method been adopted in this work.

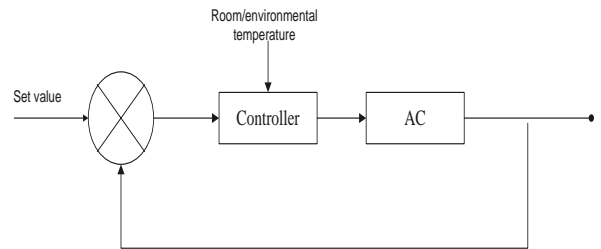

Fig. 1: conventional Control Strategy

In this traditional control strategy, the A/C reference temperature is supplied manually via a remote control unit. The system applying traditional control method also senses the environmental temperature and regulates the A/C using it and the target temperature. In this case, A/C operates continuously until the target temperature and that of the room is equal, which poses a challenge of thermal comfort apart from electric power wastage, which we want to address. Whenever there is an increase in the indoor temperature as against the desired temperature, the onboard sensor detects it and triggers the A/C on until the difference between the desired target temperature and that of the on-board sensor is zero. The consequence of this is that it makes the A/C to consume more energy due to the long duration of operation in which the room may be empty. Research shows that about 40% of the supplied energy is wasted on appliance such as the A/C without direct or immediate use in [8]. Another fact is that even if the indoor is occupied the current thermal state of the occupant is not put into consideration. For instance, the desired indoor temperature could be set at 22°C in the traditional method while the resident is feverish or sick, this would result in increased thermal discomfort which poses a health risk. Such risks in [9] might be in form of sick building syndrome or building related syndromes, which include mucous membrane irritation, breathing difficulties, irritated skin, and constitutional/neurological symptoms such as headache and fatigue.

This work has therefore proposed a design that controls the A/C based on thermal state of the resident, hence ensuring that the resident is comfortable at all times. This proposed design makes provision for efficient use of electrical energy as the operation of the A/C will now be based on the occupants' temperature, rather than being set manually as in the case of the conventional method and also the A/C will only be operational if the resident is in the apartment. The operation of the proposed design is also based on the premise that the state of the human body temperature is been harmonized with the environmental temperature and humidity. Hence, the body temperature is being considered as if it is an environmental influence which has presented the occupants level of activity, nature of cloth, hunger status, anxiety among other things. It is imperative that temperature of the human body is sensed from the most suitable and appropriate part of the body because as humidity reduces, the body losses more heat and the human body temperature also increases when the environmental temperature increases [8].

It has been established in [8] that the skin is the most viable amidst limited locations of the body that could provide adequate information about the human body's thermal state due to its complex nature. The brain, skin cell discharge frequency and the skin have been identified but due to surgical requirement before the brain temperature can be measured, its feasibility rules out leaving the skin as the most viable location of the body. Determination of the Skin's frequency of discharge is restricted to interference prone laboratory environment because of its extremely weak signal. The human skin's adaptation to environmental influence can be detected without any medical surgery. Out of the often exposed part of human body, the wrist of the hand remains most feasible point because there is a keen relationship between the temperature of the wrist and the human thermal comfort apart from its high concentration of blood vessels. The temperature of the wrist as observed in [8] can, therefore, reflect the occupant's thermal condition without compromise.

Hence, the applied control method in this work, which is depicted in Fig. 2, utilizes the temperature of the human wrist as its control temperature. This design is made such that the system is applicable to a single occupant in a room, whose wrist temperature is used to regulate the control variable (temperature) of the A/C that ensures his thermal stability and comfort at all times. Fig. 2 shows that the Human Body temperature serves as the regulation temperature in place of a certain pre-set or desired temperature value. The appropriate regulation in this design is done by a Micro-controller, ensuring that the A/C satisfies the body temperature but not the room's temperature and that the A/C ceases to operate once the occupant of the room is not on seat.

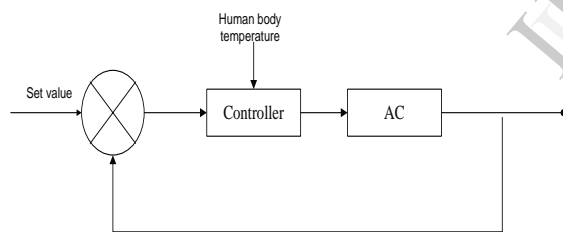

Fig. 2: the Control Strategy

#### IV. METHODOLOGY

We have applied micro-code control and thermal sensing techniques in this work by using Microcontroller as used in [10] and thermal sensing devices. This method encompasses ordered steps in form of sensing organ that senses the temperature and the control device that implement control strategy's algorithm in micro-code form based on this sensed variable. The thermal sensor is expected to sense the instantaneous value of the occupant's thermal state while the Micro-code control regulates cooling function of the A/C based on the presence of sensed values at instances, only when the occupant is present in the temperature controlled space. Modular approach of design has been adopted in this work so as to simplify it. The design is broken down into six (6) major subunits as shown in the functional block diagram of the system in Fig. 3; namely, the Power supply unit,

Temperature detecting unit, Processor unit, Display unit, Relay unit and Control key pads.

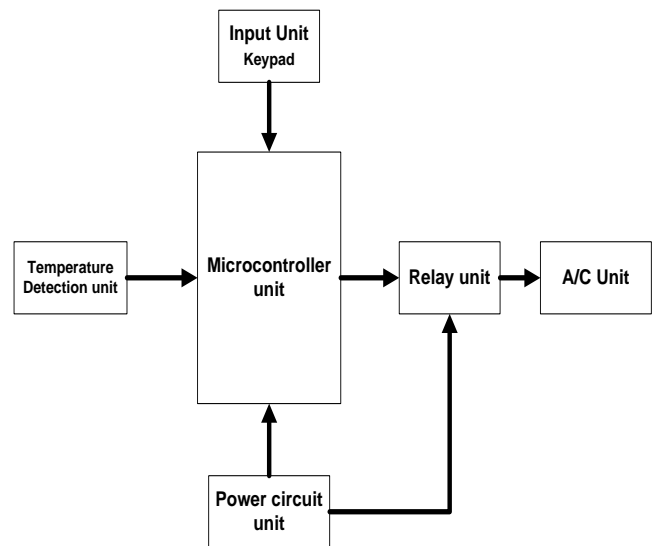

Fig. 3: Modular Design for the Proposed System

The details of each of the subunit are given below.

##### A. Power Circuit Unit

The power circuit unit serves as the only power source for the entire system. The unit supply unit provides of +5V, by converting 240V of the wall plug to a value, which is required by the main microcontroller unit and other circuitry in the design. The power circuit unit consists of Step down transformer, Rectifier circuit, Filter circuit, Voltage regulator and an isolating capacitor shown in Fig. 4. The transformer is 230V/12V step down transformer. This 12V AC supply from the transformer is converted by the rectifier into direct current (DC) voltage. The output of the rectifier is smoothed of its ripples by a 4700 $\mu$ F capacitor while the 7805 regulator is used to regulate the output voltage to a fixed value of +5V. To isolate the final output voltage from any noise and further ensure more filtration of the output +5V an additional 100  $\mu$ F Capacitor is added for this purpose.

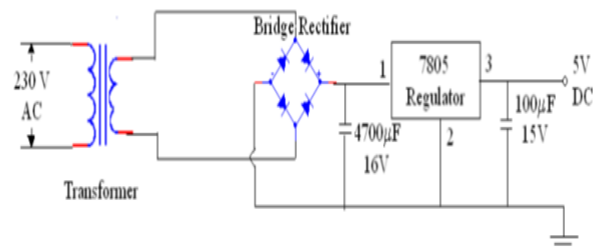

Fig. 4: Power circuit Unit

##### B. Temperature Detection Unit

The Temperature Detection Unit houses the sensor which detects the temperature of the occupant or resident of the room. The NTC thermistor (MF5B1) was chosen for this application based on some of its properties such as being glass coated, heat resistant, small in size, having high stability, and 5k ohm at 25°C and lots more. In this work,

thermistors were placed at different locations of the resident desk and connected via conducting materials to ensure that the temperature of the resident is sensed whenever in contact with the thermistor or the conducting material.

### C. Microcontroller Unit

This unit serves as the only coordinating unit of the design. The unit houses the main microcontroller unit (AT89C52). The AT89C52 is 40-pin, low-power, high-performance CMOS, 8-bit microcomputer from ATMEL, with 8K bytes of Flash programmable memory which allows easy programming and reprogramming of the chip. The AT89C52 [11] is a highly flexibility and cost effective for numerous embedded solutions. Some of the distinct features of the AT89C52 includes, 8Kbytes of Flash, 256 bytes of RAM, 32 I/O lines, three 16-bit timer/counters, a full-duplex serial port, on-chip oscillator, and clock circuitry. Fig. 4 shows the pin configuration of the AT89C52.

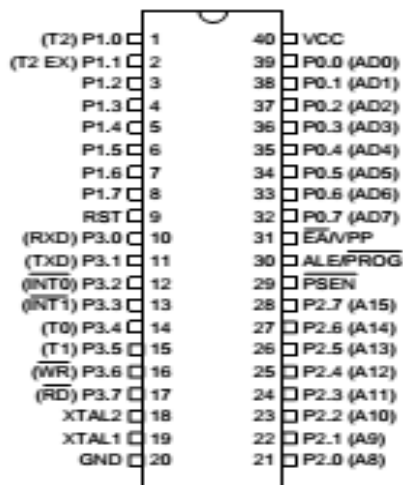

Fig. 5: Pin configuration of the AT89C52 (courtesy of ATMEL Corporation)

### D. Display and Control key Unit

This unit is enclosed in the microcontroller unit and serves as input/output sub-unit to the microcontroller unit. The display unit is responsible for the display of the output response of the microcontroller. The unit has a liquid crystal display (LCD) as the display unit which is a 20X 4 line character LCD that can displaying 80 characters at once which is described in [12]. While the control key unit consists of a switch and preset button. The switch button is used to power on and off the entire system and the preset buttons are use to increment or increment the control parameters and also set the maximum allowable temperature in the device.

### E. Relay Unit

The relay is an electrical control device that either closes or opens electrical contacts in other to deactivate or activate operation of other devices that are either mounted in the same or another electrical circuit. Our choice of this 13A/220V relay have considered reduced failure rate in switching and avoidance of short circuit scenarios. It is a single coil latching change over (CO) relay that closes an open contact while opening a closed contact when energized. The relay in this

work uses low voltage from AT89C52 to control (switches) high current or voltage consuming devices such as the A/C as used in [13], as shown in the circuit design in Fig. 7. As soon as signal is received from the microcontroller unit, the normally closed contact is released in other to close the open contact and power the A/C device.

### F. Control Code

The control code is the control logic in micro-code form that implements the control algorithm. Its routines are executed to handle all the coordination, controls and computations of the microcontroller. The control code is presented as flow chart in Fig. 6. It serves as the algorithm that describes the basic steps of the control code of the microcontroller unit.

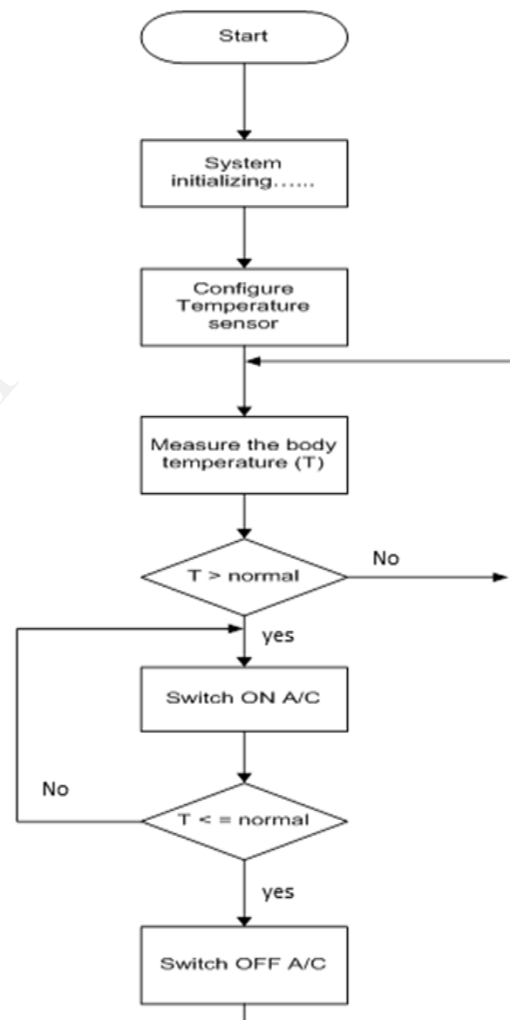

Fig. 6: Program Flow chart

The steps of the control algorithm starts with initialization of the whole device in other to make it ready to implement the other steps of the control algorithm, after which it configures the sensors' ports to sense input temperature parameters. After which the sensors' readings are sampled to acquire the temperature of the resident/occupant, which is used as the control variable of the air conditioning unit. Whenever the temperature goes above normal, the AC is triggered on and remains in operation until the temperature of



the occupant/resident returns to normal. The whole process is repeated as long as the occupant is on seat.

### V. RESULTS AND DISCUSSION

The newly applied control strategy for the AC control using human body temperature as described in the methodology was designed using the Proteus 7 software [10], as applied in [12], for circuit development and it is as presented in Fig. 7. The design consists of all the circuitries as earlier described. The simulation exercise of this work utilizes the stages of control logic code formation and circuit diagram development.

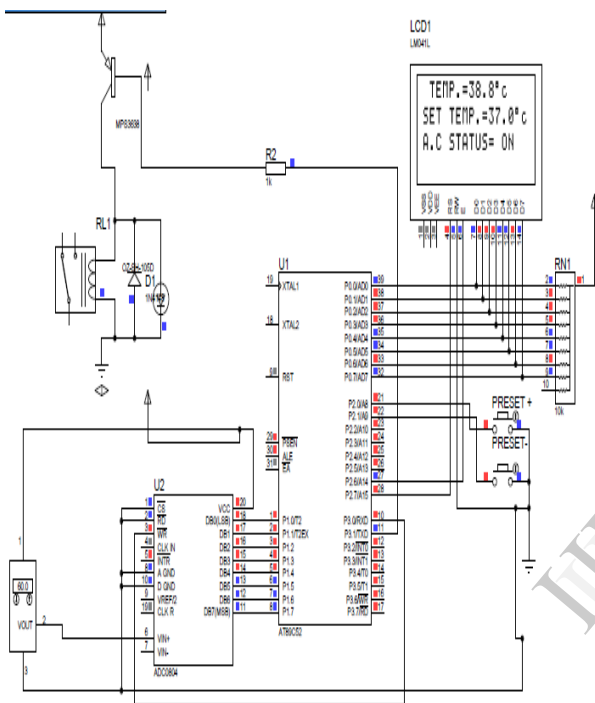

Fig. 7: Circuit Design for the proposed system.

Hardware prototype of the units were developed in one casing using breadboard component mounting and pins' jump-wire interconnections. The net list of the simulation was generated by using components explained in Design Methodology's section. The simulation was done in Proteus virtual environment. The programming aspect was done using "MikroC Pro for PIC" compiler described in [12]. Simulating circuits in virtual environment can save both time and cost to produce the hardware. The control logic code was implemented, by using its flowchart in Fig. 6, in MikroC Pro compiler and then activated for virtual simulation of the proposed system circuits in Fig. 7 in Proteus simulation environment. The MikroC Pro is a special development tool for PIC microcontrollers that serve as a platform for ease of programming and translation into hex binary files.

The prototype of the controller based design of this work is presented in Fig. 8, showing the residents hands on the table where the sensors are placed.

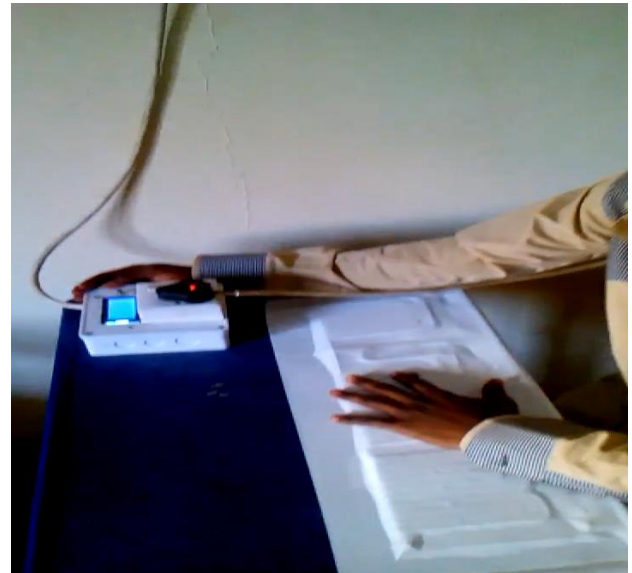

Fig. 8: The prototype of Controller based design and Resident's hand on it.

In order to evaluate the response time of the system and ascertain its responses speed to changes in human body (twist) temperature, temperature of six (6) different persons under different thermal states were sampled. The readings were classified as Normal Body Temperature and Temperature above Normal, which was obtained by subjecting the individual to some rigorous activity to increase their body temperature. The results obtained are presented in Table 1.

Table 1: System Responses

persons	Response under Normal body temperature(sec)	Response under body temperature above normal(sec)
1	11.50	11.0
2	11.60	10.56
3	12.30	10.23
4	15.42	12.21
5	16.47	9.95
6	22.0	11.20

From these response times obtained, it can be deduced that the system responds faster at higher body temperature than at normal temperature, owing to the fact an average of 14.88secs was required to switch on the system under normal temperature as against 11.20secs required when temperature is higher than normal. Hence, this shows that the system is more reactive to higher human body temperature compared with the normal temperature and swift changes in temperature of resident.

Furthermore, the operational time is being related to the power consumption of the system on the basis that the longer the AC is left on, in operation the more the energy consumed. Based on this premise, it was found that on the influence of the new controller based on the human body temperature the

operational time of the AC under any thermal state of the resident has significantly reduced as compared to the conventional controller and coupled with the fact that the system is only operational if and only if the resident is present on the work desk where the sensors are placed. Thus amount to a significant reduction in the amount of energy consumed by the AC is achieved with the new system as compared to the conventional one.

## VI. CONCLUSION

In this paper, the design and development of an improved controller for the AC control system based on human body temperature has been presented. The proposed system has shown significant results in terms of its response time to normal and above normal human body temperatures. One advantage of the new system is in the reduced operational time when compared with the conventional method due to the fact that the human temperature is the regulation factor and not the temperature of the room. Another contribution reduced operational time is that the system is only operational if the resident is in contact with the work space wherein the sensors are placed. With the significant reduction in the amount of operational time which is related to the reduction in the overall total energy consumption of the AC, the new control strategy stands a better chance of reducing the amount of energy consumed by the AC. Although, the new control has proven effective some modification may be required to make it more efficient such as the replacement of the contact sensors used by some form of contactless and wireless sensors that would not require the resident to seat on the work table before the AC control method would optimize its functions. The new method gives better thermal comfort and its highly cost effective.

## REFERENCES

- [1] W.F Chuck, J.T Kim, "Low-carbon housing and Indoor Air Quality," Sage, Feb. 2012, available at <http://ibe.sagepub.com/content/2/rules-out/1/1/5.refs.html>, May 2, 2014
- [2] Thananchai Leephakpreeda, "Implementation of Adaptive Indoor Comfort temperature Control via Embedded System for Air Conditioning Unit," *Journal of Mechanical Science and Technology*, vol. 26 (1), Springer, 2012
- [3] E. Uyigue, A. Edevbaro, O.O Godfrey, P.O Uyigue, O.G Okungbowa, "Energy Efficiency Survey in Nigeria. A Guide for Developing Policy and Legislation," Community Research and Development Centre, Nigeria, pp 10 – pp 12, 2009.
- [4] K. W. H. Mui and W. T. D. Chan, "Adaptive Comfort Temperature Model of Air Conditioned Building in Hong Kong," *Building and Environment*, vol. 38, pp 837 – 852, 2003.
- [5] T. M. Wang, I.J Liao, J.C Liao, T.W Suen, W.T Lee, "An Intelligent Fuzzy Controller for Air Condition with Zigbee Sensors," *International Journal on Smart Sensing and Intelligent Systems*, vol. 2, pp 636 – 652, 2009.
- [6] A. Patanaik, "Fuzzy Logic Control of Air Conditioners," *Indian Institute of technology*, pp 1 – 8, 2008
- [7] G.S Song et al., "Air Conditioner Operation Behaviour Based on Students' Skin Temperature in a Class Room," *Applied Ergonomics*, vol. 43, pp. 211 – 216, 2012
- [8] C. Z. Lou, G.Q Cao, D.W An, G Lou, "A New Control Strategy of Indoor Air Temperature in an Air Conditioned System," presented at the International Refrigeration and Air Conditioning Conference, 2004
- [9] M. J. Mendel, "Comentary: Air Conditioning as a Risk for Increased Use of Health Services," *International Journal of Epidemiology*, vol. 33, pp 1123 – 1126, 2004
- [10] M. A. Qureshi, Teach Yourself PIC Micro Controllers, Internet: [www.elctronicspk.com](http://www.elctronicspk.com), Jan.10, 2014
- [11] A. A. Datasheet, "Atmel Corporation," Technical Support, 2009.
- [12] M. Verle, "PIC Microcontrollers Programming in C," *Mikroelektronika*, 2009.
- [13] Vladimir Gurevich, "Electric Relays: Principles and Applications," CRC Press, FL, 2006. Internet: <http://www.taylorandfrancis.com>, May 5, 2004. G. Eason, B. Noble, and I.N. Sneddon, "On certain integrals of Lipschitz-Hankel type involving products of Bessel functions," *Phil. Trans. Roy. Soc. London*, vol. A247, pp. 529-551, April 1955.