

High Speed DA based Discrete Wavelet Transform Digital Design for Image Processing using Verilog

Reena S Rajan

Department Of Electronics and Communication Engineering
Musaliar College of Engineering and Technology
Pathanamthitta, Kerala, India

Lijesh L

Asso. Prof
Department of Electronics and Communication
Musaliar College of engineering and Technology
Pathanamthitta, Kerala, India

Abstract— In this paper, the discrete wavelet transform is used and it is the fundamental block in several schemes for image compression. Its implementation relies on filters that usually require multiplications leading to a relevant hardware complexity. Distributed arithmetic is a general and effective technique to implement multiplierless filters and has been exploited in the past to implement the discrete wavelet transform as well. This work proposes a general method to implement a discrete wavelet transform architecture based on distributed arithmetic to produce approximate results. Also here a carry save adder is used in order to reduce the time delay. The novelty of the proposed method relies on the use of result biasing techniques (inspired by the ones used in fixed-width multiplier architectures), which cause a very small loss of quality of the compressed image (average loss of 0.11 dB and 0.20dB in terms of PSNR for the 9/7 and 10/18 wavelet filters, respectively). Compared with previously proposed distributed arithmetic- based architectures for the computation of the discrete wavelet transform, this technique saves from about 20% to 25% of hardware complexity.

I. INTRODUCTION

The discrete wavelet transform algorithms have a fixed position in the processing of signals in different fields of research and industry. How DWT provides both frequency and spatial octave scale time of the analyzed signal, you will use again and again to solve and deal ever more advanced problems. DWT algorithms were first compact supports conjugate quadrature filters is based. However, a drawback with CQFs by nonlinear effects such as spatial phase shifts in the multi-scale analysis. This is in turn biorthogonal discrete wavelet algorithms where the scale and wavelet filters are symmetrical and linear phase avoided. The BDWT algorithms are generally constructed by a ladder network called lifting scheme. The method consists of successive down and pick up the steps and signal reconstruction is running the lifting power in reverse order. BDWT efficient structures for VLSI applications elevation and microprocessors have been developed. Just register, changes and total integer arithmetic implementation of the analysis and synthesis filter are required. BDWT data based on many systems and image processing tools, the conventional discrete cosine transform has based approaches exceeded. For example, in the JPEG2000 standard, the DCT has been replaced by lifting BDWT. This work proposes a general method to

implement a discrete wavelet transform architecture based on distributed arithmetic to produce approximate results. Also here a carry save adder is used in order to reduce the time delay.

A. Objectives

Inspired by result-biased techniques proposed in for fixed-width multipliers, this work aims to show that the complexity of DA-based architectures for DWT computation can be further reduced by applying result-biasing techniques. It is relevant to remark that the proposed approach is agnostic, i.e. it can be applied independently of the design criterion adopted for the addressed filters. In particular, in this work we show that i) the complexity of DA-based architectures for wavelet filters can be reduced by about 20% to 25% with a very limited performance degradation (thus result-biasing compensation can be avoided); ii) the implemented DA-based architecture for the 9/7 wavelet filters features almost the same performance and complexity as other multiplierless solutions, which have been optimized by taking advantage of the specific properties of these filters. Furthermore, the proposed solution features a large complexity reduction compared to state-of-art architectures when applied to the 10/18 wavelet filters.

B. General Background

The discrete wavelet transform has become widespread. Thanks to its properties rendered Excel correlation DWT JPEG2000 has been included in the recently approved standard for digital cinema. This has encouraged researchers and took efficient VLSI architectures for the implementation of the core computing DWT. the TPM is a filter bank .So, issued several efforts for architectures without multipliers FB structure. Factoring B-Spline is used to architectures without multipliers FB design. Recently have been other approaches, as well as proposed, for example, whole algebraic quantization coefficient rationalization polymorphic band-media application and Polynomial Factoring. Distributed Arithmetic (DA) was approximately two proposed used decades ago and has since widely used in VLSI Implementations of DSP architectures. Most of them Applications are computationally intensive with the multiplication and / or additionally, the majority operation.

the main Advantage of the distributed arithmetic approach is that it accelerates up of multiple process pre-calculating all possible Medium values and storing these values in a ROM.

II. EXISTING SYSTEM

A. DA BASED FBs FOR DWT COMPUTATION

An Indirect method based on row-column decomposition is best adapted to a hardware implementation. Distributed arithmetic (DA) was proposed about two decades ago and has since used widely in VLSI implementations of DSP architectures . Most of these applications are computation intensive with multiplication and/or addition being the predominant operation. The main advantage of distributed arithmetic approach is that it speeds up the multiply process by pre-computing all the possible medium values and storing these values in a ROM. The input data can then be used to directly address the memory and the result. In this section, we only consider the separable 2-D DWT. We proposed an efficient 2D DWT architecture based on distributed arithmetic. This architecture only uses RAM in the Modified DA based DWT-IDWT on FPGA for Image Compression.

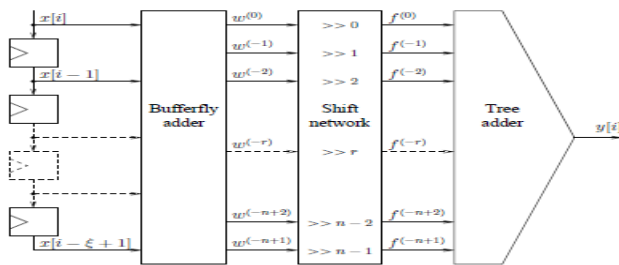

Fig.2.1: Block Diagram of Conventional Method

We proposed an efficient 2D DWT architecture based on distributed arithmetic. This architecture only uses RAM in the Modified DA based DWT-IDWT on FPGA for Image Compression. Proposed architecture uses RAM instead of ROM because the size of ROM grows exponentially when the number of inputs and internal precision increase. Distributed arithmetic and row column decomposition reduce the hardware amount and enhance the speed performance. B. Operation of the conventional architecture

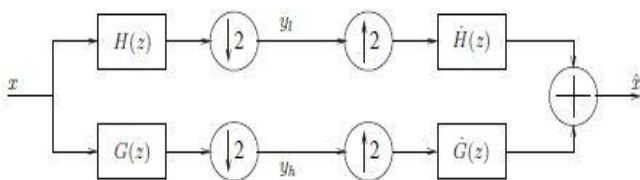

Fig.2.2: Block diagram of filter bank

This architecture uses RAM instead of ROM because the size of ROM grows exponentially when the number of inputs and internal precision increase. Distributed arithmetic and row column decomposition reduce the hardware amount and enhance the speed performance. Figure, shows a classical one level implementation of analysis and synthesis

of the DWT system using filter bank structure. The input signal $x(n)$ is filtered by the analysis process using the low pass h and the high pass g filters. The symbols $\uparrow 2$ and $\downarrow 2$ are up sampling and down sampling by a factor of two for decimating the filter results. The synthesis process is dual of its analysis process. The DWT of the signal is calculated by passing it through a series of filters. The trees known as a filter bank. At each level in the above diagram the signal is decomposed into low and high frequencies. Due to the decomposition process the input signal must be a multiple of 2^n where n is the number of levels.

III PROPOSED SYSTEM

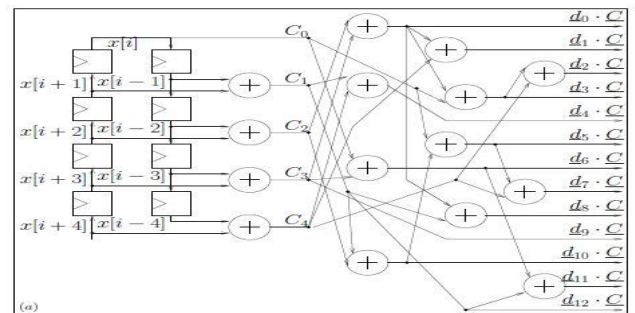

Fig.3.1 :Block diagram of proposed butterfly circuit for 9/7 wavelet filter

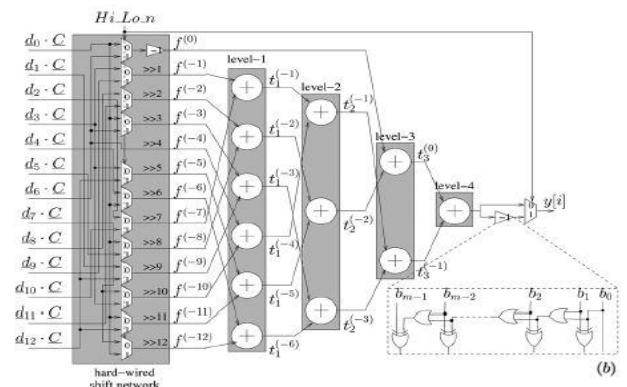

Fig.3.2:Block diagram of hardwired shift network

The result biased technique reduces the complexity of the architecture for the 9/7 and 10/18 DWT computation. These Quality figures underline the effectiveness of the proposed result biasing technique as a general method to the reduction complexity of the DA-based architectures for approximating calculation of DWT.

A. Operation Of The Proposed Architecture

It is more convenient to the binary representation of $h(j)$ and $-g(j)$, instead of $h(j)$ of $g(j)$ and to consider to find terms that are common to the low-pass and high-pass valves. As the 9/7 wavelet filters are symmetric, we can further reduce the complexity of the grid circuit. These two considerations allow to write and shaded gray for the 7 filter, where repeated common term vectors. In addition, in order to utilize filters symmetry, we introduce the column vector C . In the context of fast Fourier transform algorithms, a butterfly is a part of the calculation which combines the results of smaller discrete Fourier transforms in a larger

DFT, or vice versa, such as the breaking of a larger DFT above in sub transforms. The name "butterfly" comes from the shape of the data flow diagram in the radix-2 case. The 10/18 wavelet filter and 9/7 wavelet filter are symmetrical. This property can be exploited to design reduced complexity architecture. Hardwired shift networks are used for the shifting operation and they are followed by tree adder circuit. And the signal is used to add input samples are in the low-pass and high-pass filter implementations or subtract. Then, as for the 9/7 case, the architecture is based on a hardwired switching network and a tree adder. On the other hand, it is not possible to use the symmetry of the filter in the implementation of the architecture for the synthesis filter so and even values. Namely, since and the non-symmetric matrices, cannot be defined.

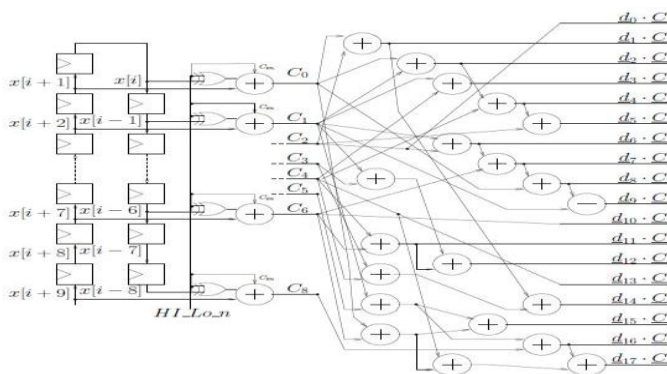

Fig.3.3 Block diagram of proposed butterfly circuit for 10/18 wavelet filter

The architecture of the result-biased tree adder is nearly the same one employed for the 9/7 filters. The only differences with respect to the circuit i) the hard-wired shift network, where the inputs to the multiplexers are the ones summarized ii) multiplication at the output. Since we observed similar carry signal probabilities for both 9/7 and 10/18 filters, the same result-biasing strategy has been employed for the implementation of the tree adder. As a consequence, the number of saved FAs is the same one obtained for the 9/7 filters, namely 57FAs.

IV MODIFIED SYSTEM

In the existing system carry propagate adders are used for the addition purpose. So the computation time grows linearly with the operand word length 'n'. Speeding up operation would require replacement by some faster adder structure. Most importantly bit arrival time is un equal, that is, higher bit arrives later than the lower bits. It is comparatively slow. In order to overcome these problems, carry save adders are used in the modified system so that fast addition takes place. Unlike the normal adders carry save adder consist of multiple one-bit full adders without any carry changing and also the time delay can be reduced. The only differences with respect to the circuit i) the hard-wired shift network, where the inputs to the multiplexers are the ones summarized ii) multiplication at the output. Since we observed similar carry signal probabilities for both 9/7 and 10/18 filters, the same result-biasing strategy has been employed but carry save adders are used.

Table 1 comparison between existing system and proposed system

EXISTING SYSTEM	PROPOSED SYSTEM
Minimum Period:1.232ns	Minimum Period:0.643ns
Minimum input arrival: 3.291ns	Minimum input arrival: 0.739ns
Maximum output time after clock:18.417ns	Maximum output time after clock: 10.914ns
Maximum combinational Path delay:16.756ns	Maximum combinational Path delay: 8.966ns

In Table 1, it shows the comparison between the existing system and the proposed system. In the combinational logic circuits the FPGA is typically implemented by using combinational logic circuits with look up tables. The table output values are just fills, when the FPGA configured it is called look up tables. It is composed of SRAM bits. The time required for one packet of data to reach from one point to another is called latency. When we are observing a system, latency due to the time delay between cause and the physical change of the system. To express how much (information) is reaching from one point to another in data transmission is called network throughput.

V CONCLUSION

Hence, the result of the result biased distributed-arithmetic-based filter architecture for approximately computing the DWT is presented. It proposed the idea to know about 9/7 and 10/18 wavelet filter. These wavelet filters are applied to reduce each of the complexity of DA-based architectures for calculating DWT, with a very low loss in terms of PSNR. Experimental results show that the proposed method reduces the complexity of DA-based architectures for performing DWT computation. By using carry save adder to the existing system the delay time can be reduced. Also the loss of quality of image can be reduced. It will give better efficiency and throughput. The result utilization can also be reduced compared with the existing system.

REFERENCES

- [1] Martina, Maurizio; Masera, Guido; Ruo roch, Massimo; Piccinini, Gianluca (2015), "Result-biased distributed-arithmetic-based filter architectures for approximately computing the dwt", *IEEE transactions on circuits and systems. i, regular papers*, vol. 62 n. 8, pp. 2103-2113. - issn 1549-8328.
- [2] B.K.Mohanty and P.K.Meher (2013), "Memory-efficient high-speed convolution-based generic structure for multilevel 2-D DWT," *IEEE Trans.Circuits Syst. Video Technol.*, vol. 23, no. 2, pp. 353-363, 2013
- [3] Y. Hu and C. C. Jong (2010), "A memory-efficient high-throughput architecture for lifting-based multi-level 2-D DWT", *IEEE Trans. Signal Proces.*, vol. 61, no. 20, pp. 4975-4987.
- [4] M. Martina, G. Masera, and G. Piccinini (2010), "Scalable low-complexity B-spline discrete wavelet transform architecture", *IET Circuits, Devices, Syst.*, vol. 4, no. 2, pp. 159-167.
- [5] M. A. Islam and K. A. Wahid (2010), "Area- and power-efficient design of Daubechies wavelet transforms using folded AIQ mapping," *IEEE Trans. Circuits Syst. II, Exp. Briefs*, vol. 57, no. 9, pp. 716-720.

- [6] S. Murugesan and D. B. H. Tay(2012), "New techniques for rationalizing orthogonal and biorthogonal wavelet filter coefficients," *IEEE Trans. Circuits Syst. I, Reg. Papers*, vol. 59, no. 3, pp. 628–637.
- [7] A. Pande and J. Zambreno(2012), "Poly-DWT: Polymorphic wavelet hardware support for dynamic image compression," *ACM Trans. Embedded Comput. Syst.*, vol. 11, no. 1, pp. 1–26.
- [8] N. Petra, D. De Caro, V. Garofalo, E. Napoli, and A. G. M. Strollo(2011), "Design of fixed-width multipliers with linear compensation function," *IEEE Trans. Circuits Syst. I, Reg. Papers*, vol. 58, no. 5, pp. 947–960.
- [9] D. De Caro, N. Petra, A. G. M. Strollo, F. Tessoro, and E. Napoli(2013), "Fixed-width multipliers and multipliers-accumulators with min-max approximation error," *IEEE Trans. Circuits Syst. I, Reg. Papers*, vol. 60, no. 9, pp. 2375–2388.
- [10] A. K. Naik and R. S. Holambe(2013), "Design of low-complexity high-performance wavelet filters for image analysis," *IEEE Trans. Image Process.*, vol. 22, no. 5, pp. 1848–1858.
- [11] S. Y. Park and P. K. Meher(2013), "Low-power, high-throughput, low-area adaptive FIR filter based on distributed arithmetic," *IEEE Trans. Circuits Syst. II, Exp. Briefs*, vol. 60, no. 6, pp. 346–350.
- [12] M. S. Prakash and R. A. Shaik(2013), "Low-area and high-throughput architecture for an adaptive filter using distributed arithmetic," *IEEE Trans. Circuits Syst. II, Exp. Briefs*, vol. 60, no. 11, pp. 781–785.
- [13] J. Xie, P. K. Meher, and J. He(2013), "Hardware-efficient realization of prime-length DCT based on distributed arithmetic," *IEEE Trans. Comput.*, vol. 62, no. 6, pp. 1170–1178.
- [14] Y. H. Chen, J. N. Chen, T. Y. Chang, and C. W. Lu(2014), "High-throughput multistandard transform core supporting MPEG/H.264/VC-1 using common sharing distributed arithmetic," *IEEE Trans. Very Large Scale Integr. (VLSI) Syst.*, vol. 22, no. 3, pp. 463–474.