

GSM Based Home Automation with Security (Using Microcontroller)

Dr. Shaik Meeravali ¹, P. Sai Prasad ²

¹H.O.D.Professor, Dept. of ECE, RRSCET, Muttangi (v), A.P.India

²M.Tech. (E.S) Student of RRSCET, Muttangi (v), A.P.India.

Abstract

The project is to develop a system, which uses mobile technology that keep control of the various units of the automobiles, which executes with respect to the signal sent by mobile. Now a day's every system is automated in order to face new challenges in the present day situation. Automated system has less manual operation, so that the flexibility, reliabilities are high and accurate. Hence every field prefers automated control systems. Especially in the field of electronics automated systems are doing better performance. Probably the most useful thing to know about the global system for mobile communication is that it is an international standard. If you travel in parts of world, GSM is only type of cellular service available. Instead of analog services. GSM was developed as a digital system using TDMA technology. For utilization of appliances the new concept has been thought to manage them remotely by using GSM, which enables the user to remotely control switching of domestic appliances. By a simple SMS sending to the GSM modem at remote place, the devices can be turned ON/OFF and the status of the devices can be sent to the prescribed mobile number programmed in the microcontroller. The range of appliances that can be controlled through telex- remote systems are many in numbers. Some of them Are as follows and this depends upon the usage priority of the appliances i.e. Industrial appliances, Music System or other electrical/electronic appliances.

Introduction

The project involves developing a system, which uses technology that keeps control of the various units of the automobiles, which executes with respect to the signal sent to the mobile. As we have the new concept has been thought to manage them remotely by using a GSM, which enables the user remotely control switching off appliances. By simply sending SMS to the modem at the remote place, the devices can be turned ON/OFF and the status of the device can be sent to the registered mobile number programmed in the microcontroller.

Existing System

In the existing system we use to check the each room and all the devices before leaving the home, and sometimes we use to forget the devices in running condition and leave that in same condition after coming from the office we will see that device in the same running condition, then we will switch off the device to the safe mode.

Proposed System

The In the proposed system the GSM is used to receive the message and transmit the message to the microcontroller. As we have two devices used GSM and other is microcontroller. The remote user sends a text message to the including command to the receiver. GSM receiver, receives message sent from the user cell phone, GSM receiver decodes the sent message and sends the command to the microcontroller. Microcontroller issues command to the appliances and the device connected will switch ON/OFF. The use and control unit will establish communication via GSM

Hardware Description

The following is the schematic block diagram of home automation with security based on GSM using a microcontroller.

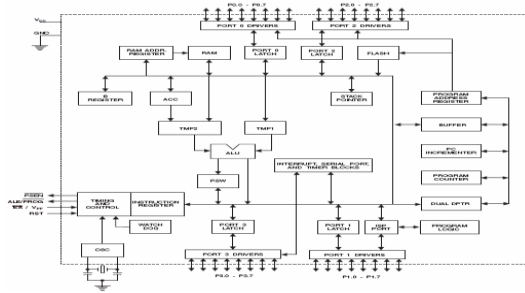

Figure: Block diagram of microcontroller

Microcontroller AT89S52

The microcontroller AT89S52 is a low power, high-performance CMOS 8-bit microcontroller with a 8k byte of in-system programmable flash memory. The ATMEL AT89S52 is a powerful microcontroller which provides a highly-flexible and cost-effective solution to many embedded controller application, it has 256 x 8-bit internal ram and having 8 interrupt sources with three 16-bit timer/counters. This is compatible with MCS-51 products, 8k byte of in-system programmable (ISP) flash memory

GSM

In the GSM we have selected a particular “SIMENS GSM MODEM” in this project. The messages are sent from the mobile set to that contain commands in written form which are then processed accordingly to perform the required task. A microcontroller based system has been proposed for our project. There are several technologies that are used extensively throughout this project report. The main concept behind this project is that to receive the sent SMS and processing it further as required to perform several operations. The type of operation to be performed depends on the nature of SMS sent.

Interfacing LCD to 89S52

Now a day electronic project without LCD looks incomplete. Interfacing with Atmel microcontroller is very task. You just have to know the proper LCD programming algorithm. LCD used here has HD44780u dot matrix LCD controller. LCD modules have 8-bit data interface and control pins. One can send data an 8-bit or in pair of two 4-bit nibbles. To display any character on LCD microcontroller has to send its ASCII values to the data bus of LCD for e.g. to display ‘AB’ microcontroller has to send two hex bytes 41h and 42h respectively. LCD display used here is having 16x2 sizes. It means 2lines each with 16characters

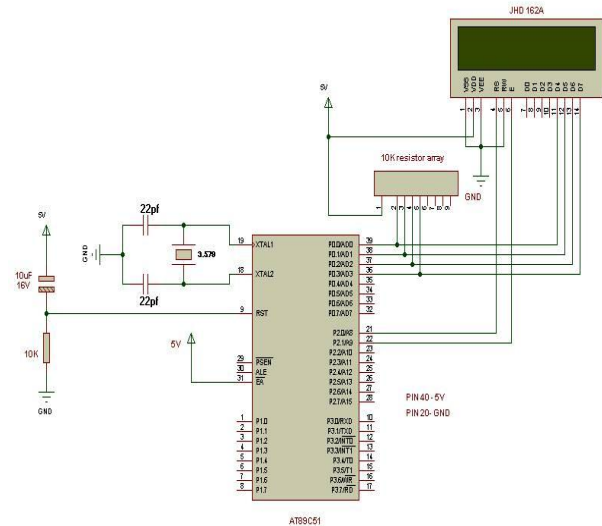

Figure: Schematic design of interfacing LCD to 89S52

LCD Initialization

This is the pit fall for beginners. Proper working of LCD depend on the how the LCD is initialized. We have to send few commands bytes to initialize the LCD. Liquid crystal display is also called as LCD is helpful in providing user interface as well as for debugging purpose. The most common type of LCD controller is HITACHI 4478 which provides a simple interface between the controllers as well as are cost effective.



Figure: LCD Display

Relay Introduction

The first relay was invented by Joseph Henry in 1835. The name relay derives from the French noun relays that indicate the horse exchange place of the postman. Generally a relay is an electrical hardware device having an input and output gate. The output gate consist in one or more electrical contacts that switch when the input gate is power, a negation, and on the base of the past relays had a wide use, for instance the telephone switching or the railway routing and crossing system. Relays are usually SPDT or DPDT but they can have many more sets of switch contacts.

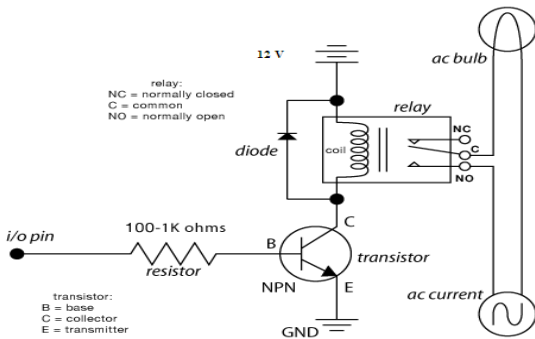

Figure: Relay circuit diagram.

This relay is used to control a high-voltage with a low-voltage signal, as in some type of modems, to control a high-current circuit with low-current signal, as in the starter solenoid of an automobile.

PIR Sensor

A passive infrared sensor (PIR Sensor) is an electronic device which measures infrared light radiating from object in its field of view. Apparent motion is detected when an infrared source with one temperature, such as a human, passes in the front of an infrared source with another temperature, such as a wall. All the objects emit what is known as black body radiation. This energy is invisible to the human eye but can be detected by electronic device designed such as a purpose. The term ‘passive’ in this instance means the PIR does not emit energy of any type but merely accepts incoming infrared radiation.

Working Procedure

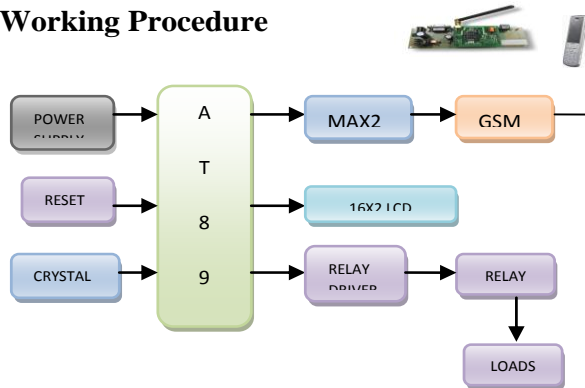

Figure: Block Diagram of Home Automation

The objective of this project is to develop a device that allows for a user to remotely control and monitor multiple home /office appliances using a cellular phone. This system will be a powerful and flexible tool that will offer this service at any time, and from anywhere with the constraints of the technologies being applied. The application of our system comes into handy when people who forget

to do simple things such as turn ON/OFF devices at their home or in their office they can now do so without their presence by the transmission of a simple text message from their mobile phone. This development, we believe, will ultimately save a lot of time especially when people don't have to come back for simple things such as to turn ON/OFF switches at home or at their office once they set out for their respective work. How we have implemented our project and the various parts involved in it, from the above representation the first mobile station is used as a transmitting section from which the subscriber sends a text message that contain command and instructions to the second mobile station which is based on a specific area where our control system is located. The mobile phone indicated in the block diagram is a Siemens GSM modem set. The received SMS message is stored in the SIM memory of the phone and then extracted by the microcontroller and processed accordingly to carry out specific operations. The LCD is used to indicate the status of the operation performed by the microcontroller and also its inclusion makes the overall system user-friendly. GSM receiver receives message sent from the user call phone, microcontroller issues commands to the appliances and the devices connected will switch ON/OFF.

Result

The project GSM based home automation with security using a microcontroller designed a complete remote handling. From owner GSM mobile sending a message to the GSM modem located in the home or office is considered to be as an input and the respective action performed by the microcontroller by switching ON or OFF the relays is considered to be the output.

Conclusion

This project we have undertaken has helped us gain a better perspective on various aspects related to our course of study as well as practical knowledge of electronic equipments and communication. We became familiar with software analysis, designing, implementation, testing and maintenance concerned with our project. The extensive capabilities of this system are what make it so interesting. From the conveniences of a simple cell phone, a user is able to control and monitor virtually any electrical devices.

Future Scope

The future implementation of this project is very great consideration the amount of time and resource it saves. The project we have undertaken

can be used as a reference or as a base for realization a scheme to be implemented in other projects of greater level such as weather forecasting, temperature updates, devices synchronization, etc. The project itself can be modified to achieve a complete Home Automation System which will then create a platform for the user to interface between himself and his household.

Reference

- [1] Mazidi, Muhammad Ali, the Microcontroller and Embedded System, Second Edition, Prentice Hall, 2007.
- [2] Holborn, P.G., Nolan, P.F., Golt, J.: An Analysis of fatal unintentional dwelling fires investigation by London Fire Brigade between 1996 and 2000. Fire Safety Journal, 1-42, (2003).
- [3] Robert R. (1998) Modern Control System. 8th Edition, New York.
- [4] Paul Horowitz and Winfield Hill (2002) The Art of Electronics, 2nd Edition Cambridge university press.

IJERT