

Dynamic Analysis of Flexible Pavements Due to Variations in Modulus of Elasticity

Sweta P Patil

Department of Civil Engineering
KLE Dr. M.S. Sheshgiri College of Engineering
& Technology, Belagavi, India

Suma Govind Lamani

Department of Civil Engineering
KLE Dr. M.S. Sheshgiri College of Engineering
& Technology, Belagavi, India

Abstract—Nowadays, the need to increase pavement service life, guaranteed high performance, reduced service and maintenance costs has been turned a greater attention on the use of reinforcements. This paper presents findings of a numerical investigation on geogrid reinforced flexible pavement roads, under dynamic loads, using a three-dimensional Finite Element Method (FEM) by using ABAQUS. Geogrids are increasingly used as a reinforced material in various divisions of Civil Engineering. This paper focuses on the study of variations of elastic modulus of each pavement layer and its corresponding stresses.

Keywords—Flexible pavement; layers; geogrids; elastic modulus;

I. INTRODUCTION

Transportation infrastructure plays a vital role in the economic and social life of all countries. Flexible pavements can be defined as layered systems that include materials on top that have higher qualities than those towards the bottom thus allowing redistribution of traffic loads from the contact surface to the underlying layers. To excessive traffic loads, many existing pavements have already reached the end of their service life. As a result, surface treatment methods and the use of new pavement reinforcement materials have been explored to improve the performance and service life of flexible pavements. The application of geosynthetic materials in highway repairs has become popular in recent years due to their high strength, durability, and ability to relieve stresses by reinforcing the pavements.

Geogrids are one type of geosynthetic reinforcement systems. They are made of polymers that are connected in parallel sets of tensile ribs with openings in between them. when the asphalt layer is compacted over geogrids, the aggregate particles penetrate through the openings of the grid resulting in the creation of strong interlock and therefore the lateral movements of the unbound material are reduced drastically.

II. ANALYSIS OF PAVEMENT MODEL

A. Methodology

A 2D flexible pavement model is created in ABAQUS software with 3 layers i.e., Asphalt layer, a granular base and a subgrade of standard thickness. The properties, sections, interactions, loading and boundary conditions are provided. The elastic modulus of one layer is varied & the maximum stress produced is noted for that layer at each varied elastic

modulus. The same procedure is followed to other two layers and the corresponding stresses is observed.

Another identical model is created with same thickness and properties, but a geogrid is placed in between asphalt and base layer and the same analysis is carried out. The results obtained in this and that of without geogrid model are compared.

B. Section Properties

The section is assumed to be solid, homogenous and deformable for the layers of pavement and the geogrid. The wheel is assumed to be discrete rigid.

C. Material Properties

Three layers of pavement are considered i.e., Asphalt layer, Granular base and Subgrade. The materials in these layers are assumed to respond linearly and elastically to the applied load. Elastic properties such as modulus of elasticity and Poisson's ratio are assumed from previous standard investigations. Some other material properties are also assumed to understand pavement conditions. The thickness of pavement layers is chosen as per code provisions of Indian Road Congress, IRC: 37-2012.

D. Loading and boundary conditions

A uniform loading of 575 kPa is applied which is equivalent to a single wheel load of 4080 kg. Horizontal base is provided with fixed support to restrict horizontal movements, while vertical displacement is allowed for one side of the layers. A uniform velocity is provided to the wheel and varied accordingly.

E. Interaction properties

Each layer has an interaction of surface to surface contact. The wheel surface and top layer surface are provided a friction of 0.3. Pavement layer surfaces are given a hard contact of 0.99 friction. Geogrid is interacted with other layers by a constraint.

III. RESULTS AND DISCUSSIONS

A. Unreinforced model

The analysis is done on the pavement without geogrids under a constant loading conditions and constant velocity. The elastic modulus is varied for each layer and the respective stresses are observed. The following are the results obtained on unreinforced pavements.

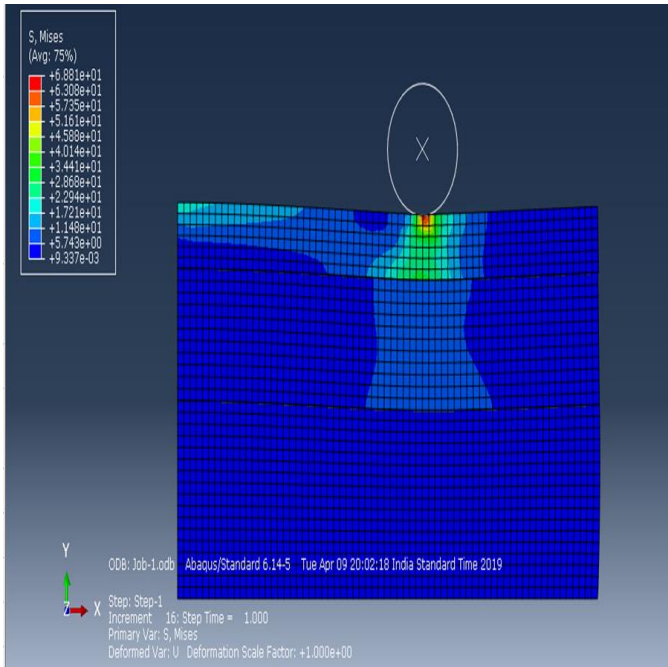

Fig. 1. Stresses at different layers of pavement without geogrid

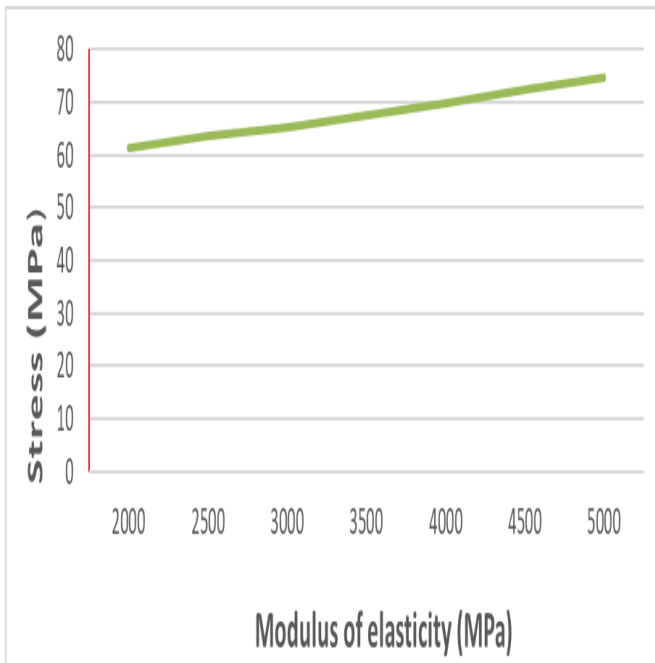

Fig. 2. Graph of elastic modulus v/s stress of asphalt layer

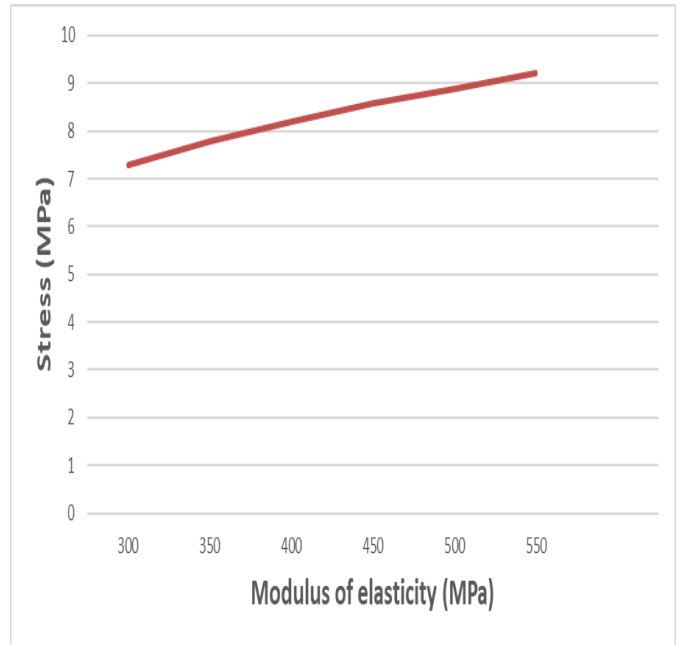

Fig. 3. Graph of elastic modulus v/s stress of base layer

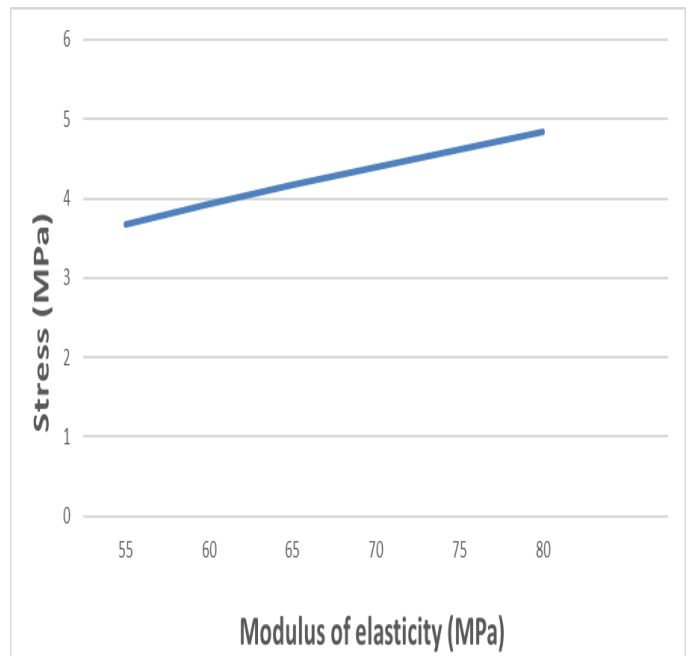

Fig.4. Graph of elastic modulus v/s stress of subgrade

It is observed that the stresses are maximum at top layer and goes on decreasing as we go down the subsequent layers. Stresses are very minimum at the subgrade layer. It is also observed that the stresses are increasing with increase in elastic modulus at each layer.

B. Reinforced model

The analysis is done on the pavement geogrid under a constant loading conditions and constant velocity. The elastic modulus is varied for each layer and the respective stresses are observed. The following are the results obtained on reinforced pavements.

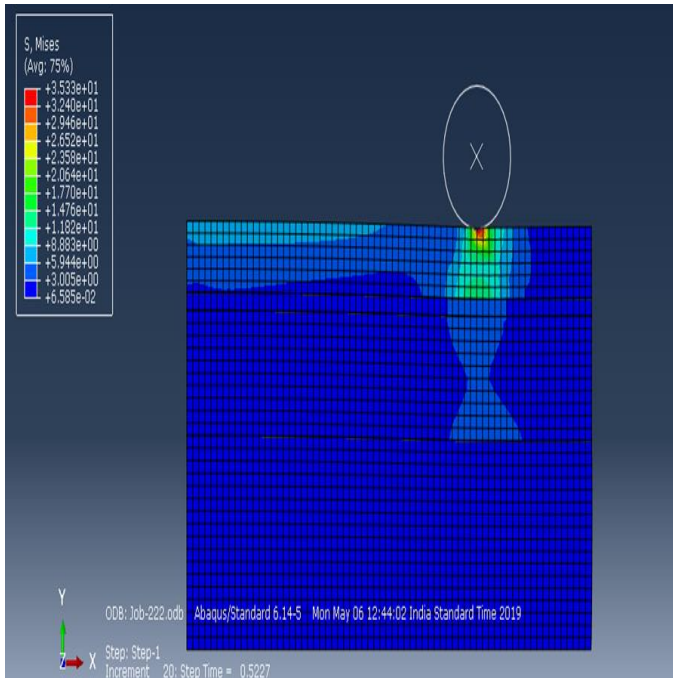

Fig. 5. Stresses at different layers of pavement with geogrid

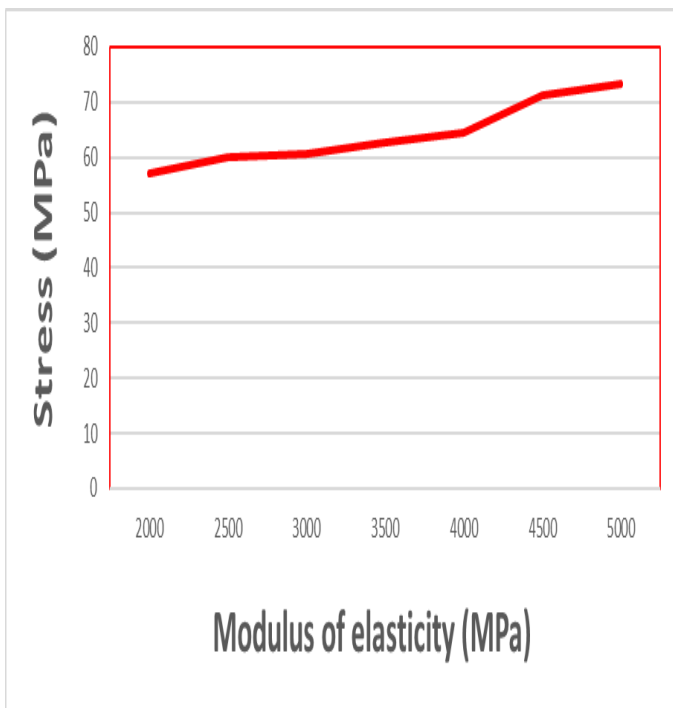

Fig. 6. Graph of elastic modulus v/s stress of asphalt layer

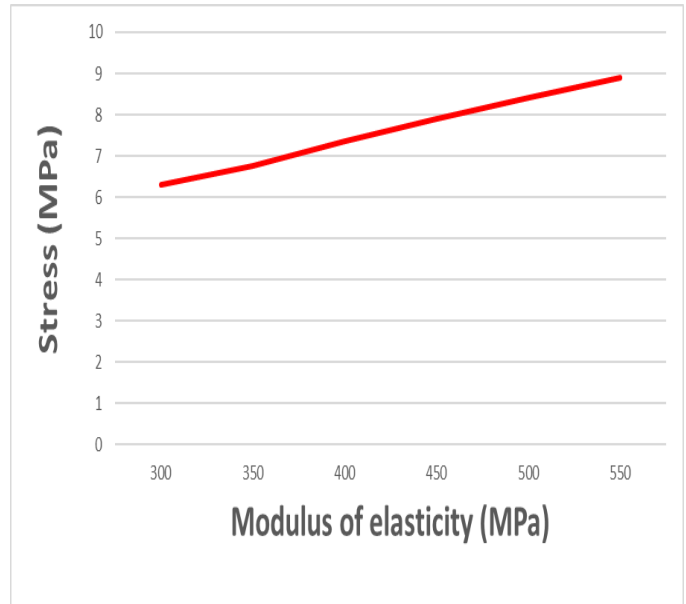

Fig. 7. Graph of elastic modulus v/s stress of base layer

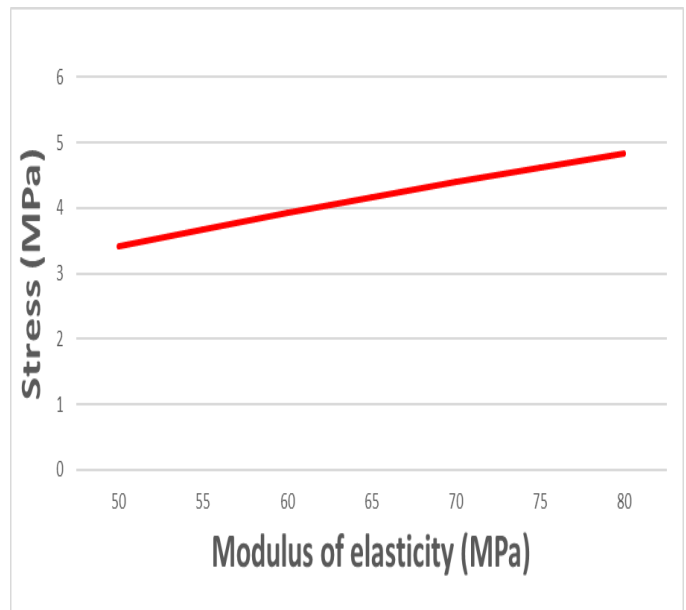

Fig. 8. Graph of elastic modulus v/s stress of subgrade

In reinforced section there is a same decrease of stresses from top to bottom and also there is an increase of stress with increasing elastic modulus. It is observed that stresses produced in reinforced sections are less than that of unreinforced section i.e., without placing geogrids at same velocities, material properties and loading conditions. The stress produced is almost 8%-10% less in reinforced pavements.

The increase in stress at each layer is because, as the elastic modulus increases, strain decreases and hence stress increases. By inserting geogrids, stresses get reduced at each layer as geogrids act as a reinforcement and helps in redistribution of load over a wider area.

IV. CONCLUSION

The finite element analysis results show that with increase in elastic modulus there is an increase in stress produced at each layer, but this stress produced is less when geogrid is provided. There is less stress produced in geogrid reinforced flexible pavement when compared to that of unreinforced flexible pavement. Geogrids acts as a reinforcement material. This function of geogrid has made the pavement more stabilize and strong. Thus, it can be concluded that use of geogrids in flexible pavements helps to reduce deformations and life span of flexible pavements can be extended.

REFERENCES

- [1] S.K.Ahirwara, J.N. Mandala, "Finite Element Analysis of Flexible Pavement with Geogrids," Transportation Geotechnics and Geocology, Saint Petersburg, Russia, 2017
- [2] Unnam Rajesh, Satish Sajja, V K Chakravarthi, "Studies on Engineering Performance of Geogrid Reinforced Soft Subgrade". 11th Transportation Planning and Implementation Methodologies for Developing Countries, Mumbai, India, 2014
- [3] José Neves, Helena Lima and Margarida Gonçalves, "A Numerical Study on the Implications of Subgrade Reinforcement with Geosynthetics in Pavement Design", vol. 143, Advances in Transportation Geotechnics 3 . The 3rd International Conference on Transportation Geotechnics (ICTG 2016)
- [4] Xin Penga, Jorge G. Zornberga, "Evaluation of load transfer in geogrids for base stabilization using transparent soil," Transportation Geotechnics and Geocology, Saint Petersburg, Russia, 2017
- [5] Rahman M.T, Mahmud K., Ahsan S., "Stress strain Characteristics of flexible pavement using finite element analysis" International Journal of Civil and Structural Engineering volume 2, no1, 2011