

Design of Contactless Braking System

Karthick N^{#1}, Pranav Sudhan A^{*2}, Pranesh Christopher L^{*3}, Praveen T^{*4}, Raghu Saravanan E^{*5}

#1 Assistant Professor - Department of Mechanical Engineering
-Kathir College of Engineering, Neelambur.

*2, 3, 4, 5 Student - Department of Mechanical Engineering
-Kathir College of Engineering, Neelambur.

Abstract: A Contactless Braking system uses Magnetic force to engage the brake, but the power required for braking is transmitted manually. The disc is connected to a shaft and the electromagnet is mounted on the frame. When electricity is applied to the coil a magnetic field is developed across the armature because of the current flowing across the coil and causes armature to get attracted towards the coil. As a result it develops a torque and eventually the vehicle comes to rest. In this project the advantage of using the Contactless braking system in automobile is studied. These brakes can be incorporated in heavy vehicles as an auxiliary brake. The Contactless brakes can be used in commercial vehicles by controlling the current supplied to produce the magnetic flux. Making some improvements in the brakes it can be used in automobiles in future.

Keywords:- Brakes, COMSOL Multiphysics, Eddy Current, Electromagnet, Parametric Sweep.

I. INTRODUCTION

Magnetic brakes

Attractive brakes are a moderately new innovation that is starting to pick up notoriety because of their high level of security. As opposed to moderating a train by means of grinding, (for example, balance or slide brakes), which can regularly be influenced by different components, for example, downpour, attractive brakes depend totally on certain attractive properties and resistance. Truth be told, attractive brakes never interact with the train.

Attractive brakes are comprised of maybe a couple lines of neodymium magnets. At the point when a metal balance (commonly copper or a copper/aluminum amalgam) goes between the columns of magnets, swirl streams are produced in the blade, which makes attractive field restricting the balance's movement.

The resultant braking power is straightforwardly relative to the velocity at which the balance is traveling through the brake component. This very property, in any case, is additionally one of attractive braking's burdens in that the vortex drive itself can never totally hold a train in perfect condition. It is then regularly important to hold the train set up with an extra arrangement of balance brakes or "kicker wheels" which are straightforward elastic tires that reach the train and successfully stop it.

Magnetic brakes can be found in two configurations:

- The brake elements are mounted to the track

or alongside the track and the fins are mounted to the underside or sides of the train. This configuration looks similar to frictional fin brakes.

□ The fins are mounted to the track and the brake elements are mounted to the underside of the train. This configuration can be found on Intamin's Accelerator Coasters (also known as Rocket Coasters) such as *KingdaKa* at Six Flags Great Adventure. Attractive brakes are noiseless and are much smoother than grinding brakes, bit by bit expanding the braking control so

that the general populations on the ride don't encounter quick changes in deceleration. Numerous advanced exciting rides, particularly those being fabricated by Intiman, have used attractive braking for quite a while. Another real crazy ride creator actualizing these brakes is Bollinger and Maxillary in 2004 on their Silver Bullet altered liner, making it the initially suspended exciting ride to highlight attractive brakes, and again utilized them on their more up to date tasks, for example, Leviathan at Canada's Wonderland. These later applications have demonstrated successfully agreeable and important fo these modified napkins which frequently give the feeling of flight. There additionally exist outsider organizations, for example, Magnatar tech. which give different designs of the innovation to be utilized to supplant and retrofit stopping mechanisms on existing crazy rides to build wellbeing, enhance rider solace, and lower upkeep expenses and work.

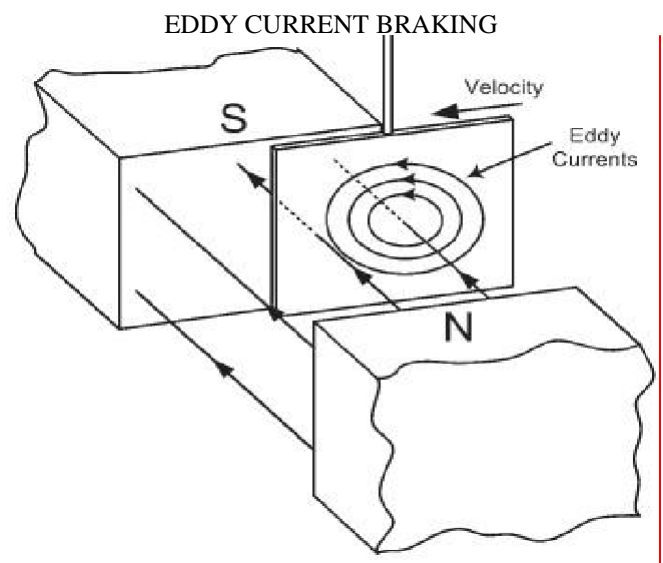

Figure 1: Generation of Eddy current Bae J. S., (2004)

Whirlpool streams are stream in a roundabout way. They get their name from "whirlpools" that are shaped when a fluid or gas streams in a roundabout way around impediments when conditions are correct. To produce whirlpool streams for an examination a "test" is utilized. Inside the test is a length of electrical channel which is framed into a loop. Rotating current is permitted to stream in the curl at a recurrence picked by the professional for the sort of test included. An element extending and falling attractive field frames in and around the curl as the rotating current courses through the loop. At the point when an electrically conductive material is put in the loop's dynamic attractive field electromagnetic, prompting will happen and whirlpool streams will be instigated in the material. Karnopp, M., (1989) Eddy streams streaming in the material will create their own "optional" attractive field which will contradict the curl's "essential" attractive field acc. To the Lenz's guideline.

INSTALLATION LOCATION

The establishment area of Electromagnetic brakes close to the moving part. Electromagnetic brakes work in a generally cool condition and fulfill all the vitality prerequisites of braking at high speeds, totally without the utilization of erosion. Because of its particular establishment area (transmission line of unbending vehicles), electromagnetic brakes have better warmth scattering ability to dodge issues that grinding brakes face.

Ordinarily, electromagnetic brakes have been mounted in the transmission line of vehicles. Fredrick, J. R (2002) The propeller shaft is partitioned and fitted with a sliding all inclusive joint and is associated with the coupling rib on the brake. The brake is fitted into the case of the vehicle by method for hostile to vibration mounting. The down to earth area of the retarder inside the vehicle keeps the immediate impingement of air on the retarder created by the movement of the vehicle. Any wind stream development inside the skeleton of the vehicle is found to have a moderately inconsequential impact broadcasting live stream around tire ranges and consequently on the temperature of both front and back circles. So the utilization of the retarder does not influence the temperature of the consistent brakes. In that way, the retarders amplify the life range of the normal brakes and keep the general brakes cool for crisis circumstance. Electromagnetic brakes work in a moderately cool condition and fulfill all the vitality prerequisites of braking at high speeds, totally without the utilization of grinding.

Because of its particular establishment area (transmission line of inflexible vehicles), electromagnetic brakes have better warmth dispersal ability to maintain a strategic distance from issues that grinding brakes face. Ordinarily, electromagnetic brakes have been mounted in the transmission line of vehicles. The propeller shaft is isolated and fitted with a sliding all inclusive joint and is associated with the coupling rib on the brake. The

brake is fitted into the undercarriage of the vehicle by method for hostile to vibration mounting. The handy area of the retarder inside the vehicle keeps the immediate impingement of air on the retarder brought about by the movement of the vehicle. Any wind stream development inside the undercarriage of the vehicle is found to have a moderately inconsequential impact reporting in real time stream around tire zones and subsequently on the temperature of both fronts what's more, back circles. So the use of the retarder does not influence the temperature of the consistent brakes. In that way, the retarders broaden the life range of the customary brakes and keep the normal brakes cool for crisis circumstance. Klingerman, Y. (1998)

II. WORKING PRINCIPLE

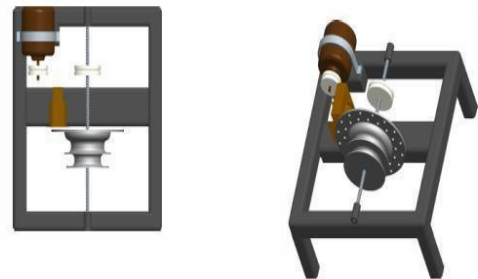

Magnetic Braking

When an electrical conductor, such as copper or aluminum, moves through the field of a permanent magnet or an electromagnet, electromagnetic induction creates eddy currents, which dissipate some of the kinetic energy into Joule heat and results in slowing the motion of the conductor. This principle is utilized in the construction of magnetic brakes. This Demonstration shows magnetic braking applied to a rotating metallic disk. This might, for example, serve to control resistance to motion in exercise machines. Magnetic braking can also find applications in roller coasters and railroad trains, in which the metallic conductor has the shape of a linear rail. In contrast to conventional friction brakes, there is no direct contact between interacting surfaces, which makes magnetic braking more reliable and reduces wear and tear.

A magnetic brake is a device that leverages strong magnetic forces to slow a vehicle down. There are various different types of magnetic brake systems, including ones that use electromagnets to actuate traditional friction pads, and those

That leverage magnetic repulsion itself to provide resistance. These can be found on a variety of vehicles, from trains to roller coasters.

By increasing or decreasing the amount of electric current, the stopping power of an Eddy current brake can be correspondingly attenuated up or down. Rather than pads pressing harder on a rotor, the resistive magnetic force is amplified. Though there is no physical contact, the process still generates increased slowing, along with heat, as a result of the resistance. Eddy current brake systems are used mostly in larger vehicles, like trains.

A sub-type of the Eddy current brake is known as the *linear* Eddy current brake. Instead of the normal circular design, magnetic coils are wound around a straight rail. The coils alternate between a positive and negative magnetic charge, so, when activated, generate resistance and slowing action. This design is less widely used than traditional electromagnetic brakes on train systems, but, in places like Europe, is becoming more common on high-speed rail systems. Unpowered versions of the linear design which instead use permanent, rare Earth magnets are the brake of choice on most roller coasters. As anyone who has ridden a roller coaster will be aware, these non-electromagnetic types work on an on-off basis, and cannot be easily modulated. This results in very abrupt periods of deceleration, and, for this reason, they are not a popular choice on more comfort-oriented vehicles, like trains.

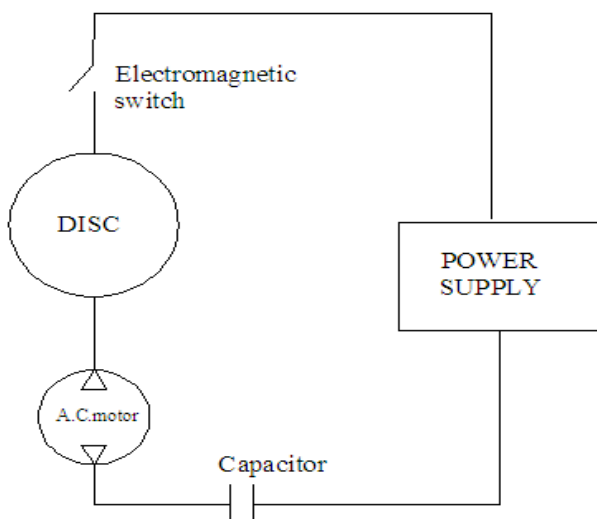

III. FUTURE OF EDDY CURRENT

BRAKING

The assortment of papers that have been reviewed in this paper shows that use of eddy current dampers has seen a number of diverse applications. However, many of the applications are not directed towards the commercial market and are developed to suit a niche field. The eddy current damper does have numerous advantages over other damping systems. For instance, due to the non-contact nature of the damper it does not change the dynamics of the structure or cause mass loading and added stiffness, as many other damping mechanisms do. Additionally, because the damper does not contact the structure, there is no need for a viscous fluid, seals, or the periodic maintenance needed by many other damping and braking systems. Furthermore, eddy current damping systems are easy to install, and the damping force can easily be controlled through adjustment of the position or strength of the magnets. The question left unanswered is, where will eddy current damping mechanisms be in the future? There are several locations that are particularly well suited for eddy current dampers, but perhaps the most promising is in space. The advantages listed above provide a combination of

attributes that are not available in other damping mechanisms. When a device is placed into orbit, the system must function for its entire lifespan without requiring any type of maintenance. This can place limitations on the type of damper used, leaving few systems left. Perhaps the two damping systems that require the least amount of maintenance after their placement are eddy current dampers and constrained layer damping.

The drawback of constrained layer damping is that it modifies the system's structural properties, while the drawback of the eddy current damper is that it typically requires a second structure to support the magnets. However, the extremely cold temperatures that are present in space actually improve the damping performance of the eddy current damper, due to the decrease in resistivity of the conductor.

The opposite is the case for constrained layer damping treatments, because the extreme cold can cause stiffening of the viscoelastic material and the vacuum pressure could cause outgassing if not properly sealed, thus making their use in space problematic. The use of these dampers in space may be the key to developing better eddy current technology that may open a commercial market. One commercial market that may be a key location for eddy current damping is the vibration absorbers used in vehicles. The dampers currently used tend to require replacement throughout the life of the automobile and lose effectiveness over time. The eddy current damper could potentially replace these devices if sufficient research were carried out. A second area of the automobile that may benefit from the use of eddy currents is the braking system. The use of eddy currents for braking purposes could potentially lead to regenerative braking that would reduce the amount of electrical energy required to power the electromagnets. The automobile market is a key commercial market that can typically open doors for the technology used. Finally, the use of eddy currents for active damping mechanisms may allow a more effective damper to be developed.

The use of eddy current dampers as active control mechanisms is limited in the current literature. One application that may be effective is to displace the magnet relative to the moving conductor, in an attempt to increase the net velocity between the two devices and instigate a higher damping force. Other active control methods may use electromagnets to damp vibrations out. If the amount of research into eddy current damping continues to grow, this type of damper will surely find its way out of niche applications and into the commercial market.

Advantages

These are non-mechanical; no moving parts hence no friction. Fully resettable, no parts need to be replaced. Can be activated at will via electrical signal, Low maintenance cost, Operates at any rotational speed.

Disadvantages

Braking force diminishes as speed diminishes with no ability to hold the load in position at stand still. That could be considered to be a safety issue, but it really means that friction braking may need to be used as well. Eddy-current brakes can only be used where the infrastructure has been modified to accept them.

IV. CONCLUSION

With all the advantages of electromagnetic brakes over friction brakes, they have been widely used on heavy vehicles where the 'brake fading' problem is serious. The same concept is being developed for application on lighter vehicles. A Halbach magnetized mover was applied to a high-speed eddy current braking system. Based on analytical 2-D field solutions considering dynamic end effect, the magnetic field, eddy current distribution, and forces according to the secondary relative permeability and conductivity were presented.

It was observed that the air-gap flux density has a non uniform distribution for the high speed. Comparisons between numerical simulations and experimental data were also presented.

REFERENCES

- [1] Bae J. S., Kwak M. K. and Inman D. J. (2004). Vibration Suppression of Cantilever Beam Using Eddy Current Damper. *Journal of Sound and Vibration*, (Accepted)
- [2] Baz, A. and Poh, S., (2000), Performance Characteristics of the Magnetic Constrained Layer Damping, *Shock and Vibration Digest*, Vol. 7, 81–
- [3] Cadwell L. H., (1996), Magnetic Damping: Analysis of an Eddy Current Brake Using an Air Track, *Journal of Physics*, Vol. 64, 917–923.
- [4] Cunningham, R. E., (1986), —Passive Eddy Current Damping as a Means of Vibration Control in Cryogenic Turbo machinery, *NASA Technical Paper number NASA-TP-2562*, Access No. N86 24722.
- [5] Davis, L. C. and Reitz, J. R., (1971), —Eddy Currents in Finite Conducting Sheets, *Journal of Applied Physics*, Vol. 42, No. 11, 4119–4127.