

# Design of an Arduino Nano-Based Electric Vehicle Fire Protection System

Dr. Jyoti Sathe  
Assistant Professor  
Priyadarshini College of  
Engineering,  
Nagpur, Maharashtra, India

Bhupesh Bisen  
Priyadarshini College of  
Engineering,  
Nagpur, Maharashtra , India

Aboli Chakole  
Priyadarshini College Engineering,  
Nagpur, Maharashtra India

Umendra Bisen  
Priyadarshini College of  
Engineering,  
Nagpur, Maharashtra ,India

Sahil Pullarwar  
Priyadarshini College of  
Engineering,  
Nagpur, Maharashtra , India

Sejal Shende  
Priyadarshini College of  
Engineering,  
Nagpur, Maharashtra , India

**Abstract** - The rapid growth of electric vehicles demands reliable safety solutions to mitigate battery related hazards. Lithium-ion energy storage systems are susceptible to thermal instability caused by overheating, overcharging, internal defects, or short-circuit conditions. This work proposes an intelligent protection framework that continuously supervises critical parameters associated with battery operation. Multiple sensing units, including temperature, gas, and electrical measurement modules, are employed to track system behavior in real time. The acquired data is processed through a microcontroller to detect abnormal patterns indicating unsafe operating conditions. Upon identification of critical states, the system initiates immediate protective actions such as isolation of the power source using relay control and activation of alert mechanisms. The proposed approach enables early hazard identification and ensures rapid preventive response without manual intervention. This solution significantly enhances operational reliability and minimizes the risk of fire incidents in electric mobility applications system efficiency. Thermal stress within battery packs and drive components can accelerate degradation if not properly controlled. Furthermore, variability in operating conditions, such as temperature and load demand, complicates control strategies and requires robust and adaptive management systems. Addressing the challenges in electric vehicles (EVs) requires an integrated approach combining advanced battery technologies, efficient power electronics, and intelligent control systems. The implementation of robust battery management systems with accurate state estimation and effective thermal regulation enhances safety and extends battery life. High- efficiency converters and optimized motor drives can minimize energy losses and improve overall system performance. In addition, the development of fast- charging infrastructure and smart grid integration supports reliable and scalable EV deployment. Continuous innovation in materials, algorithms, and system design is essential to achieve sustainable and high-performance electric mobility solutions.

## 1 INTRODUCTION

The adoption of electric vehicles (EVs) is driven by the need to reduce greenhouse gas emissions and dependence on fossil fuels. Advances in battery technology, power electronics, and charging infrastructure have significantly improved vehicle performance and accessibility. Governments and industries are actively supporting EV deployment through policies, incentives, and research initiatives. However, challenges such as battery safety, cost optimization, and charging network expansion remain key areas for ongoing development. Overall, EVs represent a sustainable transition toward cleaner and more efficient transportation systems. Lithium-ion batteries are widely used in modern energy storage systems due to their high energy density, long cycle life, and relatively low self-discharge rate. They operate through the reversible movement of lithium ions between the anode and cathode during charging and discharging processes. These batteries are commonly applied in electric vehicles, portable electronics, and renewable energy systems. Despite their advantages, they require proper thermal management and protection circuits to ensure safe operation. Continuous research is focused on improving their safety, efficiency, and overall performance. Electric vehicles (EVs) encounter multiple system-level challenges that influence their efficiency and reliability. A key concern is the non-linear behavior of battery characteristics, which affects state-of-charge estimation and overall energy management. Power electronic converters and motor drive systems may also introduce switching losses and electromagnetic interference, reducing

## 2 LITERATURE REVIEW

- [1] P. Sun, analyzed fire incidents in lithium-ion batteries and identified key causes such as thermal runaway, internal short circuits, and overcharging. Their study highlighted that such incidents may persist for longer durations and release harmful gases, emphasizing the importance of early detection systems.
- [2] T. V. P. Kumar, proposed a battery management system

capable of monitoring voltage, current, and temperature. Their approach utilized a microcontroller to identify abnormal conditions and initiate protective actions, including alerts and disconnection of the battery. [3]Pandya and Timbadia , reviewed various thermal management techniques, including air cooling, liquid cooling, and phase-change materials. Their findings indicate that effective temperature regulation plays a crucial role in maintaining battery performance and preventing overheating.[4]P.Gopinathan , developed an IoT-based charger monitoring system that tracks electrical and thermal parameters during charging. The system transmits real-time data and enables automatic response mechanisms in case of unsafe conditions.[5] M . Kutschenreuter , investigated fire behavior in electric vehicles within underground environments. Their study revealed that battery-related fires generate intense heat and toxic emissions, requiring advanced safety strategies. [6] B. V. Manikandan, designed a battery monitoring system that measures key parameters and activates protection mechanisms through a control unit. Their work demonstrated improved reliability and safety of battery operation. [7] M. Kutschenreuter, further examined fire safety challenges in enclosed infrastructures. Their analysis emphasized the need for improved detection and suppression systems due to high heat release and hazardous gases during battery failure. [8]A. Jaibhai, implemented an Arduino-based monitoring system that observes battery conditions during charging. The system detects abnormal behavior and initiates protective actions to enhance operational safety. [9]V.T.Navajeevan, proposed a multi-sensor approach incorporating temperature, gas, and smoke detection. Their system improves hazard identification by analyzing sensor data and triggering timely responses. [10] B. Karamkar, reviewed battery management technologies, focusing on monitoring techniques and thermal regulation. Their study highlighted that continuous parameter supervision significantly improves battery performance and minimizes safety risks

### 3 METHODOLOGY

The proposed system is designed to identify hazardous conditions in electric vehicle battery systems through continuous parameter monitoring and automated control. A combination of sensing units is employed to observe critical variables associated with battery operation. These include temperature sensors for thermal variation, gas and smoke detectors for emission analysis, and electrical sensors for measuring voltage and current behavior. All sensing elements are interfaced with a microcontroller-based control unit, which serves as the central processing component. The acquired data is continuously evaluated to detect deviations from predefined safe operating limits.

Specific conditions such as abnormal temperature rise, presence of combustible gases, or irregular electrical patterns

are considered indicators of potential risk. Upon detection of unsafe conditions, the control unit initiates protective actions to mitigate damage. A relay-based isolation mechanism is used to disconnect the power source, thereby preventing further escalation. In addition, alert signals are generated to indicate the occurrence of a fault condition.

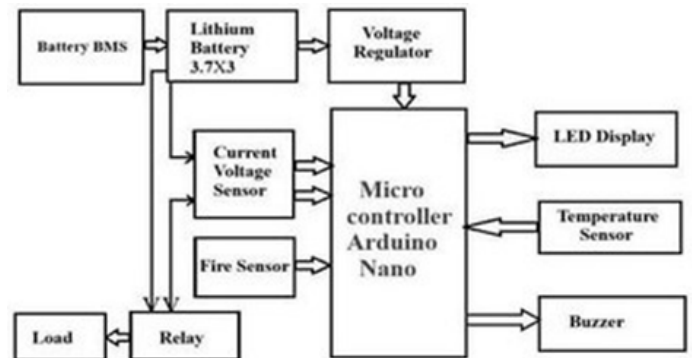

Fig 1.The Block Diagram Proposed System

### 4 PROPOSED MODEL

The proposed model presents a smart and reliable battery monitoring and protection system for electric vehicle (EV) applications, designed to enhance operational safety and efficiency. The system is built around microcontroller-based control unit that continuously acquires real-time data such as voltage, current, and temperature from integrated sensing modules. A regulated power supply ensures stable functioning of all electronic components, while signal conditioning circuits improve measurement accuracy. The model incorporates a current sensor and a digital temperature sensor to detect abnormal conditions such as overcurrent and overheating. An intelligent control algorithm processes the sensed data to estimate battery condition and trigger protective actions when predefined thresholds are exceeded. A relay or switching mechanism is used to isolate the battery from the load during fault conditions, preventing further damage. Visual and audible alert systems, including an LCD display, LED indicators, and a buzzer, provide immediate user feedback.

The inclusion of thermal monitoring enhances early fault detection and reduces the risk of thermal runaway. The system is designed to be cost-effective, scalable, and adaptable to different EV configurations. Overall, this proposed model improves battery reliability, extends lifespan, and supports safe and efficient electric vehicle operation

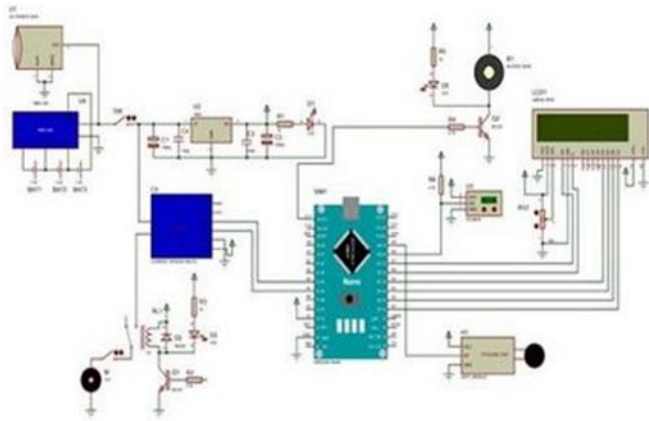

Fig. 2. Circuit Diagram

The hardware setup of the proposed system is designed to monitor critical conditions within the electric vehicle battery environment and enable immediate protective response. The implementation consists of sensing modules, a control unit, and output components integrated to ensure reliable operation. Temperature sensing is achieved using a digital sensor capable of accurately tracking variations in battery heat levels. Gas detection is incorporated to identify the presence of harmful emissions that may indicate unsafe conditions. Electrical parameters such as current and voltage are measured using dedicated monitoring modules to observe system behavior under different operating states

## 5 RESULT

The system was tested under controlled conditions to evaluate its effectiveness in identifying unsafe operating states within electric vehicle battery systems. The sensing units continuously captured variations in thermal, gaseous, and electrical parameters during operation. The acquired data was processed by the control unit to determine system status based on predefined safety limits. To validate performance, abnormal scenarios such as elevated temperature, presence of gas emissions, and irregular current behavior

All sensing units are interfaced with a microcontroller, which serves as the central processing element. The controller continuously acquires input signals and evaluates them against predefined safety thresholds. Based on this evaluation, the system determines whether the operating condition is within safe limits or requires intervention. For protective action, a relay-based switching mechanism is implemented to isolate the power source during fault conditions. In addition, alert components such as an audible indicator and display module are included to provide immediate notification of abnormal events. The integration of these hardware elements ensures coordinated operation between detection and response. The overall design emphasizes simplicity, reliability, and ease of integration, making it suitable for practical deployment in electric vehicle safety applications.

The system successfully detected these deviations and initiated immediate control actions. The power supply was isolated through a relay mechanism, while alert signals provided clear indication of fault conditions. The response time was observed to be rapid, enabling timely intervention before critical escalation. The coordinated functioning of sensing, processing, and control elements demonstrated consistent and stable operation throughout testing. The obtained results indicate that the proposed system effectively identifies early-stage hazardous conditions and ensures prompt protective response. This contributes to improved safety and dependable performance of electric vehicle battery systems.

## 6 CONCLUSION

This work presents the development of an intelligent safety system for electric vehicle battery applications, aimed at reducing fire-related risks through continuous monitoring and automated response. The proposed framework integrates multiple sensing elements with a microcontroller to monitor thermal and electrical conditions in real time. By comparing system parameters with predefined limits, potential hazards can be detected at an early stage. The implemented protection mechanism ensures immediate action under unsafe conditions by isolating the power source and generating alert signals. This prompt response minimizes the risk of damage and improves operational safety. The system demonstrates reliable performance in identifying abnormal behavior during battery operation. The proposed approach enhances overall reliability and supports safer deployment of electric vehicle technologies. Its modular structure also allows future improvements and integration with advanced battery management systems, making it suitable for practical applications in modern electric mobility systems.

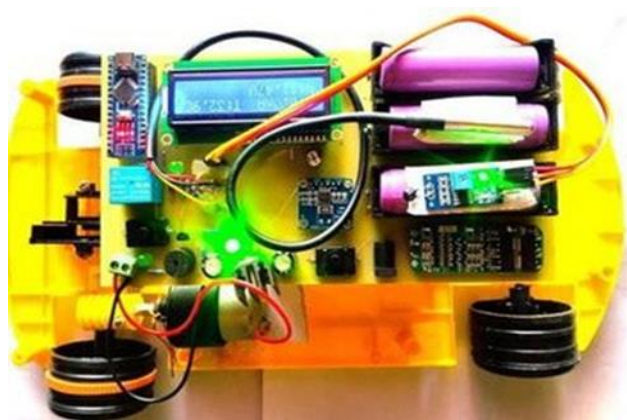

Fig. 3. The hardware setup of the proposed

## REFERENCE

- [1] P. Sun, R. Bisschop, H. Niu, and X. Huang, "A Review of Battery Fires in Electric Vehicles," RISE Research Institutes of Sweden, 2020. [2] T. V. P. Kumar, U. Rajendra, and G. V. Prasad, "EV battery management system with temperature and fire protection," in E3S Web of Conferences, ICMPC, 2023.
- [2] C. Pandya and D. Timbadia, "A Detailed Review on cooling systems in electric vehicles," International Research Journal of Engineering and Technology (IRJET), 2021.
- [3] P. Gopinathan, M. Sasikaran, M. Vaishya, M. Saikrishna, and D. Sakthivel, "Design and implementation of IoT-based charger monitoring and fire protection for EV system," International Journal of Scientific and Research Publications (IJSART), vol. 11, no. 5, 2025.
- [4] M. Kutschenreuter, S. Klüh, M. Lakkonen, R. Rothe, and F. Leismann, "How Electric Vehicles change the fire safety design in underground structures," Fire Safety Journal, 2022.
- [5] B. V. Manikandan, P. Kiruthickroshan, M. Vasantha Kumar, and L. Chandra sekeran, "Battery Management System with charge monitor and fire protection for electrical drive," International Journal of Electrical Engineering Research, 2021.
- [6] M. Kutschenreuter, S. Klüh, M. Lakkonen, R. Rothe, and F. Leismann, "Fire Safety Considerations for Electric Vehicles in underground facilities," Fire Technology, 2023.
- [7] A. Jaibhai, V. Hanamghar, N. Pawar, and S. Maske, "Electric Vehicle battery management system with charge monitoring and fire protection," International Journal of Engineering Research and Technology (IJERT), 2022.
- [8] V. T. Navajeevan, R. Rakesh, T. Jose, and M. Sandeep, "EV Battery Management System with charge monitoring and fire protection," International Journal of Innovative Research in Electrical, Electronics, Instrumentation and Control Engineering, 2023.
- [9] B. Karamkar, M. Jamadar, T. Gaikwad, A. Shrivastav, and S. Tarale, "A Review on Design and development of battery management system for electric vehicle," International Journal of Scientific Engineering and Technology Research, 2022.