

IJERT

ISSN : 2278-0181

International Journal of Engineering Research & Technology

Publish & Find Papers @



www.ijert.org

 **BROWSE**

OPEN  ACCESS

Call for Papers

DESIGN OF A VOLTAGE-CONTROLLED PFC CUK CONVERTER-BASED PMBLDCM DRIVE FOR FAN

RAJESH.R

PG student, ECE Department
Anna University Chennai
Regional Center, Coimbatore
Tamilnadu, India
Rajesh791096@gmail.com

Dr.S.N.DEEPA

Assistant Professor, ECE Department
Anna University Chennai
Regional Center, Coimbatore
Tamilnadu, India
deepapsg@gmail.com

Abstract:-This paper deals with the design of a Cuk DC-DC converter for a BLDC drive. A three-phase voltage source inverter is used as an electronic commutator to operate PMBLDCM used in a fan. It uses the concept of the voltage control at dc link proportional to the desired speed of the PMBLDCM. The speed of the motor is controlled to have the optimum speed of the fan and also to improve the power factor. The proposed drive is fed from a single phase ac supply through a diode rectifier followed by a Cuk converter and a dc link capacitor. The proposed PMBLDCM drive (PMBLDCMD) is designed and modeled, and its performance is evaluated in Matlab-Simulink environment.

Keywords: *Cuk converter, power factor (PF) correction (PFC), permanent-magnet (PM) brushless dc motor (PMBLDC), voltage contr*

1.INTRODUCTION

The use of a permanent-magnet (PM) brushless dc motor (PMBLDCM) in low-power appliances is increasing because of its features of high efficiency, wide speed range, and low maintenance. It is a rugged three phase synchronous motor due to the use of PMs on the rotor. The commutation in a PMBLDCM is accomplished by solid state switches of a three phase voltage source Inverter (VSI). Its application to a fan results in an improved efficiency of the system if operated under speed control. The fan exerts constant torque (i.e., rated torque) on the PMBLDCM while operated in speed control mode. The BLDC fan with PMBLDCM has low running cost, long life, and reduced mechanical and electrical stresses compared to a single phase induction motor-based fan.

A PMBLDCM has developed torque proportional to its phase current and its back electromotive force (EMF), which is proportional to the speed. Therefore, a constant current in its stator windings with variable voltage across its terminals maintains constant torque in a PMBLDCM under variable speed operation. A speed control scheme is proposed which uses a reference voltage at dc link proportional to the desired speed of the permanent magnet brushless direct current

(PMBLDCM) motor. However, the control of VSI is only used for electronic commutation based on the rotor position signals of the PMBLDC motor.

The PMBLDCMD is fed from a single phase ac supply through a diode bridge rectifier (DBR) followed by a capacitor at dc link. It draws a pulsed current with a peak higher than the amplitude of the fundamental input current at ac mains due to an uncontrolled charging of the dc link capacitor. This results in poor power quality (PQ) at ac mains in terms of poor power factor (PF) of the order of 0.728, high total harmonic distortion (THD) of ac mains current at the value of 81.54%, and high crest factor (CF) of the order of 2.28. Therefore, a PF correction (PFC) convertor among various available converter topologies is almost inevitable for a PMBLDCMD. Moreover, the PQ standards for low power equipments, such as IEC 61000-3-2, emphasize on low harmonic contents and near unity PF current to be drawn from ac mains by these drives.

These are very few publications regarding PFC in PMBLDCMDs despite many PFC topologies for switched mode power supply and battery charging applications. This paper deals with an application of a PFC converter for the speed control of a PMBLDCMD. For the proposed voltage controlled drive, a Cuk dc-dc converter is used as a PFC converter because of its continuous input and output currents, small output filter, and wide output voltage range as compared to other single switch converters. Moreover, apart from PQ improvement at ac mains, it controls the voltage at dc link for the desired speed of the fan. The detailed modeling, design, and performance evaluation of the proposed drive are presented.

1. PROPOSED SPEED CONTROL SCHEME

Fig.1 shows the proposed speed control scheme which is based on the control of the dc link voltage reference as an equivalent to the reference speed. However, the rotor position signals acquired by Hall effect sensors are used by an electronic commutator to generate switching sequence for the VSI feeding the PMBLDC motor, and therefore, rotor position is required only at the commutation points.

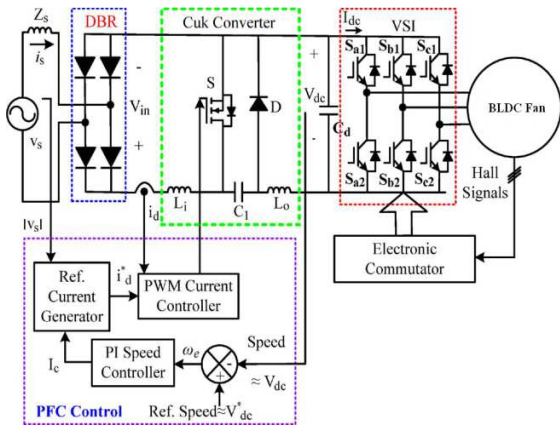

Fig. 1. Control scheme of the proposed Cuk PFC converter – fed VSI- based PMBLDCM

The Cuk dc-dc converter controls the dc link voltage using capacitive energy transfer which results in non pulsating input and output currents. The proposed PFC converter is operated at a high switching frequency for fast and effective control with additional advantage of a small size filter. For high-frequency operation, a metal-dioxide-semiconductor field-effect transistor (MOSFET) is used in the proposed PFC converter, whereas insulated gate bipolar transistors (IGBTs) are used in the VSI Bridge feeding the PMBLDCM because of its operation at lower frequency compared to the PFC converter.

The PFC control scheme uses a current multiplier approach with a current control loop inside the speed control loop for continuous-conduction-mode operation of the converter. The control loop begins with the processing of voltage error (V_e), obtained after the comparison of sensed dc link voltage (V_{dc}) and a voltage (V_{dc}^*) equivalent to the reference speed, through a proportional-integral (PI) controller to give the modulating control signal (I_c). This signal (I_c) is multiplied with a unit template of input ac voltage to get the reference dc current (I_d^*) and compared with the dc current (I_d) sensed after the DBR. The resultant current error (I_e) is amplified and compared with a saw tooth carrier wave of fixed frequency (f_s) to generate the pulse width modulation (PWM) pulse for the Cuk converter. Its duty ratio (D) at a switching frequency (f_s) controls the dc link voltage at the desired value. For the control of current to PMBLDCM through VSI during the step change of the reference voltage due to the change in the reference speed, a rate limiter is introduced, which limits the stator current of the PMBLDCM within the specified value which is considered as double the rate current in this work.

2. DESIGN OF PFC CULK CONVERTER

The proposed PFC Cuk converter is designed for a PMBLDCM with main considerations on the speed control of the Air-Con and PQ improvement at ac mains. The dc link voltage of the PFC converter is given as,

$$V_{dc} = V_{in}D / (1-D) \quad (1)$$

Where V_{in} is the average output of the DBR for a given ac input voltage (V_s) related as,

$$V_{in} = 2\sqrt{2}V_s/\pi \quad (2)$$

The Cuk converter uses a boost inductor (L_i) and a capacitor (C_1) for energy transfer. Their values are given as,

$$L_i = DV_{in} / \{f_s(\Delta I_{Li})\} \quad (3)$$

$$C_1 = DI_{dc} / \{f_s\Delta V_{C1}\} \quad (4)$$

Where ΔI_{Li} is a specified inductor current ripple, ΔV_{C1} is a specified voltage ripple in the intermediate capacitor (C_1), and I_{dc} is the current drawn by the PMBLDCM from the dc link.

A ripple filter is designed for ripple-free voltage at the dc link of the Cuk converter. The inductance (L_o) of the ripple filter restricts the inductor peak-to-peak ripple current (ΔI_{Lo}) within a specified value for the given switching frequency (f_s), whereas the capacitance (C_d) is calculator for the allowed ripple in the dc link voltage (ΔV_{Cd}). The values of the ripple filter inductor and capacitor are given as,

$$L_o = (1-D) V_{dc} / \{f_s(\Delta I_{Lo})\} \quad (5)$$

$$C_d = I_{dc} / (2\omega\Delta V_{Cd}) \quad (6)$$

The PFC converter is designed for a base dc link voltage of $V_{dc} = 297.1$ V at $V_s = 220$ V for $f_s = 40$ kHz, $I_s = 4.5$ A, $\Delta I_{Li} = 0.45$ A (10% of I_{dc}), $I_{dc} = 3.5$ A, $\Delta I_{Lo} = 3.5$ A ($\approx I_{dc}$), $\Delta V_{Cd} = 4$ V (1% of V_o), and $\Delta V_{C1} = 220$ V ($\approx V_s$). The design values are obtained as $L_i = 6.6$ mH, $C_1 = 0.24$ μ F, $L_o = 0.84$ mH, and $C_d = 1591$ μ F.

3. MODELING OF PFC CONVERTER-BASED PMBLDCM

The PFC converter and PMBLDCM are the main components of the proposed drive, which are modeled by mathematical equations, and a combination of these models represents the complete model of the drive.

3.1. PFC Converter

The modeling of the PFC converter consists of the modeling of a speed controller, a reference current generator, and a PWM controller as given here in after.

3.1.1. Speed Controller:

The speed controller is a PI controller which tracks the reference speed as an equivalent reference voltage. If, at the k th instant of time, $V_{dc}^*(k)$ is the reference dc link voltage and $V_{dc}(k)$ is the voltage sensed at the dc link, then the voltage error $V_e(k)$ is given as,

$$V_e(k) = V_{dc}^*(k) - V_{dc}(k) \quad (7)$$

The PI controller output $I_c(k)$ at the k th instant after processing the voltage error $V_e(k)$ is given as,

$$I_c(k) = I_c(k-1) + K_p \{V_e(k) - V_e(k-1)\} + K_i V_e(k) \quad (8)$$

Where K_p and K_i are the proportional and integral gains of the PI controller.

4.1.2. Reference Current Generator

The reference current at the input of the Cuk converter (i_d^*) is,

$$i_d^* = I_c(k) v_{Vs} \tag{9}$$

Where v_{Vs} is the unit template of the ac mains voltage, calculated as,

$$v_{Vs} = v_d / V_{sm}; v_d = |v_s|; v_s = V_{sm} \sin \omega t \tag{10}$$

Where V_{sm} and ω are the amplitude (in volts) and frequency (in radians per second) of the ac mains voltage.

4.1.3. PWM controller

The reference input current of the Cuk converter (i_d^*) is compared with its current (i_d) sensed after DBR to generate the current error $\Delta i_d = (i_d^* - i_d)$. This current error is amplified by gain k_d and compared with fixed frequency (f_s) saw tooth carrier waveform $md(t)$ to get the switching signal for the MOSFET of the PFC Cuk converter as,

$$\text{if } k_d \Delta i_d > m_d(t) \text{ then } S = 1 \text{ else } S = 0 \tag{11}$$

where S denotes the switching of the MOSFET of the Cuk converter and its values "1" and "0" represent "on" and "off" conditions, respectively.

3.2. PMBLDCMD

The PMBLDCMD consists of an electronic commutator a VSI, and a PMBLDCM.

4.2.1 Electronic Commutator:

The electronic commutator uses signals from Hall-effect position sensors to generate the switching sequence for the VSI.

4.2.2. VSI

The output of VSI to be fed to phase "a" of the PMBLDC motor is calculated from the equivalent circuit of a VSI-fed PMBLDCM shown in Fig.2 as,

$$v_{ao} = (V_{dc}/2) \text{ for } S_{a1} = 1 \tag{12}$$

$$v_{ao} = (-V_{dc}/2) \text{ for } S_{a2} = 1 \tag{13}$$

$$v_{ao} = 0 \text{ for } S_{a1} = 0, \text{ and } S_{a2} = 0 \tag{14}$$

$$v_{an} = v_{ao} - v_{no} \tag{15}$$

where v_{ao} , v_{bo} , v_{co} , and v_{no} are the voltages the three phases (a, b, and c) and neutral point (n) with respect to the virtual midpoint of the dc link voltage shown as "o" in Fig.. The voltages v_{an} , v_{bn} , and v_{cn} are the voltages of the three phases with respect to the neutral terminal of the motor (n), and V_{dc} is the dc link voltage. The values 1 and 0 for S_{a1} or S_{a2} represent the "on" and "off" conditions of respective IGBTs of the VSI.

The voltages for the other two phases of the VSI feeding the PMBLDC motor, i.e., v_{bo} , v_{co} , v_{bn} , and v_{cn} , and the switching pattern of the other IGBTs of the VSI (i.e., S_{b1} , S_{b2} , S_{c1} , and S_{c2}) are generated in a similar way.

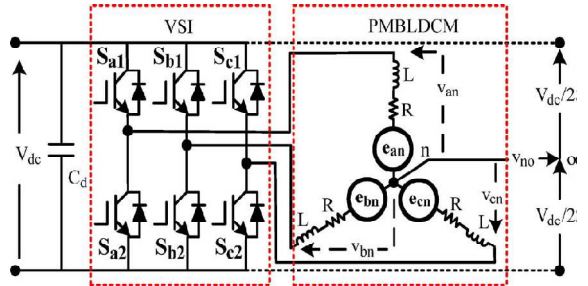

Fig.2. Equivalent circuit of a VSI-fed PMBLDCMD

4.2.3 PMBLDC motor

The PMBLDCM is modeled in the form of a set of differential equations (11) given as,

$$v_{an} = Ri_a + p\lambda_a + e_{an} \tag{16}$$

$$v_{bn} = Ri_b + p\lambda_b + e_{bn} \tag{17}$$

$$v_{cn} = Ri_c + p\lambda_c + e_{cn} \tag{18}$$

In the equations, p represents the differential operator (d/dt), i_a , i_b and i_c are currents, λ_a , λ_b , and λ_c are flux linkages, and e_{an} , e_{bn} , and e_{cn} are phase-to-neutral back EMFs of PMBLDCM, in respective phases; R is the resistance of motor windings / phase.

Moreover, the flux linkages can be represented as,

$$\lambda_a = L_s i_a - M(i_b + i_c) \tag{19}$$

$$\lambda_b = L_s i_b - M(i_a + i_c) \tag{20}$$

$$\lambda_c = L_s i_c - M(i_b + i_a) \tag{21}$$

Where L_s is the self-inductance / phase and M is the mutual inductance of PMBLDCM winding / phase.

The developed torque T_e in the PMBLDCM is given as,

$$T_e = (e_{an}i_a + e_{bn}i_b + e_{cn}i_c) / \omega_r \tag{22}$$

Where ω_r is the motor speed in radians per second.

Since PMBLDC has no neutral connection

$$i_a + i_b + i_c = 0 \tag{23}$$

From (15) – (21) and (23), the voltage (v_{no}) between the neutral point (n) and midpoint of the dc link (o) is given as,

$$v_{no} = \{ v_{ao} + v_{bo} + v_{co} - (e_{an} + e_{bn} + e_{cn}) \} / 3 \tag{24}$$

From (19) – (21) and (23), the flux linkages are given as,

$$\lambda_a = (L_s + M) i_a, \quad \lambda_b = (L_s + M) i_b, \quad \lambda_c = (L_s + M) i_c \tag{25}$$

From (16) – (18) and (25), the current derivatives in generalized state space form are given as,

$$p i_x = (v_{xn} - i_x R - e_{xn}) / (L_s + M) \quad (26)$$

where x represents phase a, b, or c.

The back EMF is a function of rotor position (θ) as,

$$e_{xn} = K_b f_x(\theta) \omega_r \quad (27)$$

where x can be phase a, b, or c and accordingly $f_x(\theta)$ represents a function of rotor position with a maximum value ± 1 , identical to trapezoidal induced EMF, given as

$$f_a(\theta) = 1 \quad \text{for } 0 < \theta < 2\pi \quad (28)$$

$$f_a(\theta) = 1 \{ (6/\pi) (\pi - \theta) \} - 1 \quad \text{for } 2\pi/3 < \theta < \pi \quad (29)$$

$$f_a(\theta) = -1 \quad \text{for } \pi < \theta < 5\pi/3 \quad (30)$$

$$f_a(\theta) = \{ (6/\pi) (\pi - \theta) \} + 1 \quad \text{for } 5\pi/3 < \theta < 2\pi \quad (31)$$

The functions $f_b(\theta)$ and $f_c(\theta)$ are similar to $f_a(\theta)$ with phase differences of 120° and 240° , respectively.

Therefore, the electromagnetic torque expressed as,

$$T_e = K_b \{ f_a(\theta) i_a + f_b(\theta) i_b + f_c(\theta) i_c \} \quad (32)$$

The mechanical equation of motion in speed derivative form is given as,

$$P \omega_r = (P/2) (T_e - T_l - B \omega_r) / (J) \quad (33)$$

Where ω_r is the derivative of rotor position θ , P is the number of poles, T_l is the load torque in newton meters, J is the moment of inertia in kilogram square meters, and B is the friction coefficient in newton meter seconds per radian.

The derivative of rotor position is given as,

$$p\theta = \omega_r \quad (34)$$

Equations (16) – (34) represent the dynamic model of the PMBLDC motor.

4. PERFORMANCE EVALUATION PMBLDCMD

The proposed PMBLDCMD is modeled in Matlab-Simulink environment, and its performance is evaluated for fan load. The fan load is considered as a constant torque load equal to the rated torque with variable speed. The performance of the proposed PFC drive is evaluated on the basis of various parameters such as THD and CF of the ac mains current and displacement power factor (DPF) and PF at different speeds of the motor as well as variable input ac voltage. For the performance evaluation of the proposed drive under input ac voltage variation, the dc link voltage is kept constant at 298 V which is equivalent to a 1500-r/min speed of the PMBLDCM. Figures and above tables show the obtained results of the proposed PMBLDCMD in a wide range of the speed and the input ac voltage

5.1 PERFORMANCE PMBLDCMD DURING STARTING

The performance of the PMBLDCMD during starting is evaluated while feeding it from 220-V ac mains with the reference speed set at 1000 r/min and rated torque. It shows the starting performance of the drive depicting voltage (v_s) and current (i_s) at ac mains, voltage at dc link (V_{dc}), speed of motor (N), electromagnetic torque (T_e), and stator current of phase "a" (i_a). A rate limiter is introduced in the reference voltage to limit the starting current of the motor as well as the charging current of the dc link capacitor. The PI controller tracks the reference speed so that the motor attains reference speed smoothly within 0.375 s while keeping the stator current within the desired limits, i.e., double the rated value. The current waveform at input ac mains is in phase with the supply voltage demonstrating near unity PF during the starting.

5.2. PERFORMANCE OF PMBLDCMD UNDER SPEED CONTROL

The performance of PMBLDCMD for speed control at constant rated torque and 220-V ac mains voltage during transient and steady-state conditions of the PMBLDCMD are discussed.

5.2.1 Transient Condition

The performance of the drive during the speed transient is evaluated for acceleration and retardation of the compressor. The reference speed is changed from 1000 to 1500 r/min and from 1000 to 500 r/min for the performance evaluation of the compressor at rated load under speed control. It is observed that the speed control is fast and smooth in either direction, i.e., acceleration or retardation, with PF maintained at near unity value. Moreover, the stator current of PMBLDCM is less than twice the rated current due to the rate limiter introduced in the reference voltage.

5.2.2 Steady-State Condition

The performance of PMBLDCMD under steady-state speed condition is obtained at different speeds as summarized in Table II which demonstrate the effectiveness of the proposed drive in a wide speed range. Fig.4.3 shows the linear relation between motor speed and dc link voltage. Since the reference speed is decided by the reference voltage at dc link, it is observed that the control of the reference dc link voltage controls the speed of the motor.

5.2.3. PQ Performance of the PMBLDCMD

The performance of PMBLDCMD in terms of PQ indices, i.e., THD_i, CF, DPF, and PF, is obtained for different speeds as well as loads. These results are near unity PF and reduced THD of ac mains current in wide speed range of the PMBLDCM. The THD_i and harmonic spectra of ac mains current drawn by the proposed drive at 500- and 1500-r/min speeds demonstrating less than 5% THD_i in a wide range of speed.

5.2.4. Performance of the PMBLDCMD under Varying Input AC Voltage.

The performance of the proposed PMBLDCMD is evaluated under varying input ac voltage at rated load (i.e. rated torque and rated speed) to demonstrate the effectiveness of the proposed drive for a fan in various practical situations.

The current and its THD at ac mains, DPF, and PF with ac input voltage. The THD of ac mains current is within specified limits of international norms at near unity PF in a wide range of ac input voltage

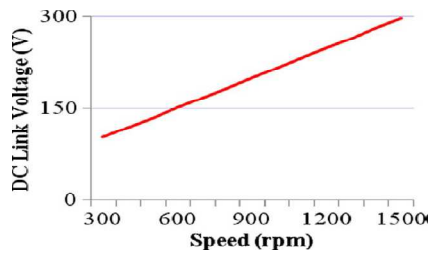

Fig.3. Variation of dc link voltage with speed for proposed PFC drive at rated torque and 220 V ac input

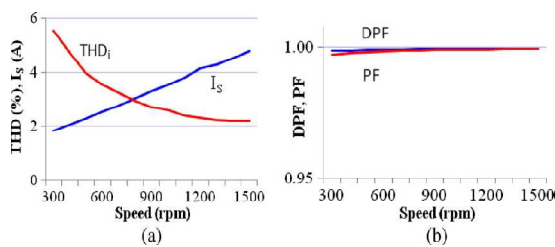

Fig. 4. PQ indices of proposed drive under speed control at rated torque and 220 V ac input. (a) Variation of I_s and its THD. (b) Variation of DPF and PF

Table1. Performance of the proposed drive under speed control at 220-v input ac voltage (V_s)

V_{DC} (V)	Speed (rpm)	THDi (%)	DPF	PF	I_s (A)
104.0	300	5.55	0.9990	0.9975	1.82
119.0	400	4.74	0.9990	0.9979	2.05
135.5	500	4.00	0.9993	0.9984	2.30
167.5	700	3.25	0.9994	0.9988	2.79
185.5	800	2.98	0.9995	0.999	3.04
200.0	900	2.75	0.9995	0.9991	3.29
216.5	1000	2.63	0.9996	0.9992	3.54
233.0	1100	2.43	0.9996	0.9993	3.79
250.0	1200	2.33	0.9997	0.9993	4.15
265.5	1300	2.24	0.9997	0.9994	4.29
281.5	1400	2.23	0.9996	0.9994	4.53
298.0	1500	2.22	0.9996	0.9994	4.79

5. CONCLUSION

A new speed control strategy for a PMBLDCMD using the reference speed as an equivalent voltage at dc link has been simulated for a BLDC Fan employing a Cuk PFC converter. The speed of PMBLDCM has been found to be proportional to the dc link voltage; thereby, a smooth speed control is observed while controlling the dc link voltage. The introduction of a rate limiter in the reference dc link voltage effectively limits the motor current within the desired value during the transient condition. The PFC Cuk converter has ensured near unity PF in a wide range of the speed and the input ac voltage. Moreover, PQ indices of the proposed PFC drive are in conformity to the International standard IEC 61000-3-2. The problems of poor power factor, inrush current and speed control in the BLDC fan has been mitigated by the proposed voltage controlled PFC Cuk converter based PMBLDCM drive.

REFERENCE

- [1] B. Singh.; G. D. Chaturvedi, (2006) "Analysis, design and development of single switch Cuk ac-dc converter for low power battery charging application," in Proc. IEEE PEDES.
- [2] B. Singh.; B. N. Singh.; A. Chandra, ;K. Al-Haddad.; A. Pandey.; D. P. Kothari, (2003) "A review of single-phase improved power quality ac-dc converters," IEEE Trans. Ind. Electron., vol. 50, no. 5, pp. 962-981.
- [3] C. J. Tseng ;, C. L. Chen,(1999) "A novel ZVT PWM Cuk power factor corrector," IEEE Trans. Ind. Electron., vol. 46, no. 4, pp. 780-787.
- [4] C. L. Puttaswamy.; B. Singh.; B. P. Singh, (1995)"Investigations on dynamic behavior of permanent magnet brushless dc motor drive," Elect. Power Compon. Syst., vol. 23, no. 6, pp. 689-701.
- [5] N. Mohan, M.;Undeland,.;W. P. Robbins,(1995) Power Electronics: Converters, Applications and Design. Hoboken, NJ: Wiley.
- [6] Sanjeev Singh.; Bhim Singh (2012)"A Voltage Controlled PFC Cuk converter-based PMBLDCM drive for Air-conditioners", IEEE transactions on industry applications, Vol-48, no.2.
- [7] T. J. Sokira.; W. Jaffe(1989) Brushless DC Motors: Electronic Commutation And Control. New York.