

# Design, Fabrication and Comparison of Heat Transfer Analysis in Annular Disc Fin and Annular Stepped Fins by Experimental and Numerical Methods

Ganshkumar .R

Mechanical engineering,  
SNS COLLEGE OF TECHNOLOGY,  
Coimbatore, Tamil Nadu, India.

Gurumoorthi. K

Mechanical engineering,  
SNS COLLEGE OF TECHNOLOGY,  
Coimbatore, Tamil Nadu, India.

Kiran. J

Mechanical engineering,  
SNS COLLEGE OF TECHNOLOGY,  
Coimbatore, Tamil Nadu, India.

Premnath. P. K

Mechanical engineering,  
SNS COLLEGE OF TECHNOLOGY,  
Coimbatore, Tamil Nadu, India.

Raghavan. M

Mechanical engineering,  
SNS COLLEGE OF TECHNOLOGY,  
Coimbatore, Tamil Nadu, India.

**Abstract** - Rapid movement of heat is require in a growing number of engineering applications to avoid system overheating and increase the life span of components. Annular Stepped Fin (ASF) requires less material than Annular Disc Fin (ADF) while retaining the ability to produce the same cooling rate in a convective environment. The basic mechanism of heat transfer through fin is to conduct heat from a heat source via the fins, and then dissipate he heat to the surrounding air by convection. In this work, we are going to analyze the heat transfer in annular stepped fin by experimental and numerical methods.

## 1. INTRODUCTION

The term extended surface is commonly used to depict an important special case involving heat transfer by conduction within a solid and heat transfer by convection (and/or radiation) from the boundaries of the solid. Until now, we have considered heat transfer from the boundaries of a solid to be in the same direction as heat transfer by conduction in the solid. In contrast, for an extended surface, the direction of heat transfer from the boundaries is perpendicular to the principal direction of heat transfer in the solid. Although there are many different situations that involve such combined conduction-convection effects, the most frequent application is one in which an extended surface is used to specifically to enhance heat transfer between a solid and an adjoining fluid. Such an enhance surface is termed a fin.

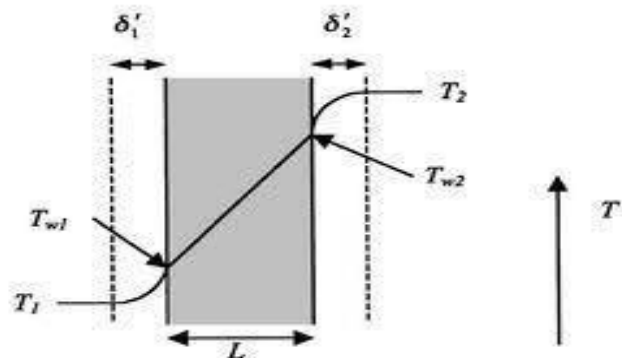

Fig 1.1 Temperature variation across the length

However, there are many situations for which increasing  $h$  to the maximum possible value is either insufficient to obtain the desired heat transfer rate or the associated costs are prohibitive. Such costs are related to the blower or pump power requirements needed to increase  $h$  through increased fluid motion. Moreover, the second option of reducing  $T_{\infty}$  is often impractical. Examining figure, however, we see that there exists a third option. That is, the heat transfer rate may be increased by increasing the surface area across which the convection occurs. This may be done by employing fins that extend from the wall into the surrounding fluid. The thermal conductivity of the fin material has a strong effect on the temperature distribution along the fin and therefore influences the degree to which the heat transfer rate is enhanced. Ideally, the fin material should have a larger thermal conductivity to minimize the temperature variation from its base to its tip. In the limit of infinite thermal conductivity, the entire fin would be at the

temperature of the base surface, thereby providing the maximum possible heat transfer enhancement.

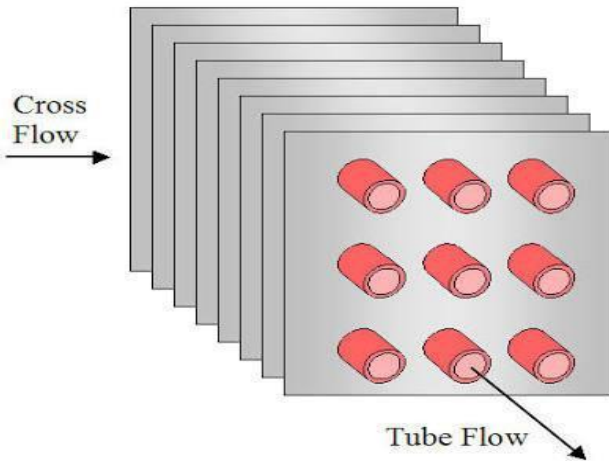

Fig 1.2 Heat exchanger

Different fin configurations are illustrated in figure. A straight fin is any extended surface that is attached to the plane wall. It may be of uniform cross-sectional area, or its cross-sectional area may vary with the distance  $x$  from the wall. An annular fin is one that is circumferentially attached to a cylinder, and its cross section varies with radius from the wall of the cylinder. The foregoing fin type have rectangular cross section, whose area may be expressed as a product of the fin thickness  $t$  and the width  $w$  for straight fins or the circumference for annular fin. In contrast a pin fin is an extended surface of circular cross section. The fin pin may be uniform or non uniform cross section. In any application, selection of a particular fin configuration may depend on space, weight, manufacturing, and cost consideration, as well as on extent to which the fin reduce the surface convection coefficient and increase the pressure drop associated with flow over the fins.

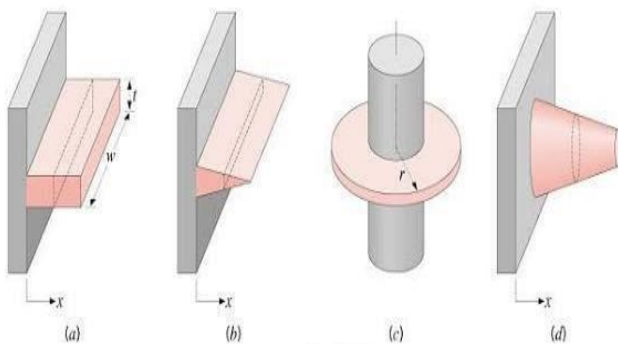

Fig 1.3 Types of fin

2. LITREATURE REVIEW

2.1. Kundu B, Das PK. Performance analysis and optimization of annular fin with a step change in thickness

A fin must be thin to maximize the surface area to volume ratio. Tapered profiles are difficult to fabricate and may be impossible to implement. However, the fin thickness near

the tip can be easily reduced in a step-wise manner by adopting a suitable stepped profile. Kundu and Das analytically determined the temperature distribution of a concentric annular fin with a step change in thickness. Under dehumidifying surface conditions, Kundu analyzed the profile of ASFs (annular stepped fins) to determine their performance. This profile was shown to have an improved heat-transfer rate per unit fin volume compared to a constant thickness profile. Kundu et al presented an approximate analysis of the maximum heat flow in annular fin arrays with rectangular stepped profiles and convective surface conditions. Their results demonstrated that an ASF array always provides a greater cooling rate than an ADF (annular disc fin) array for the same fin volume. However, their analysis considered only convective surface conditions.

2.2. Torabi M, Yaghoobi H. Two dominant analytical methods for thermal analysis of convective step fin with variable thermal conductivity

Torabi and Yaghoobi demonstrated two primary analytical methods based on differential transformation for the thermal analysis of convective stepped longitudinal fins with variable thermal conductivities. Arslanturk extended this analysis to include radiative heat transfer at the fin surfaces, and optimized the fin performance using the homotopy perturbation method. He assumed that both surfaces of the fin radiated to the vacuum of outer space at a very low temperature equal to absolute zero. The same problem was solved by Torabi et al for nonzero absolute zero surrounding temperatures using the differential transform method.

The profile shape of a stepped fin is similar to that of a constant thickness fin; therefore, such a fin is easier to fabricate than a variable-thickness fin. A stepped fin not only makes efficient use of the fin material but also induces turbulent flow over its surface. Thus, the average heat-transfer coefficient for fins with stepped surfaces is always greater than that of fins without stepped surfaces. A stepped fin with a thinner tip effectively utilizes the fin material, as the heat conduction rate is reduced from the base to the tip. Analytical results have been presented for stepped annular fins with linear surface conditions to simplify the calculations. However, it is more difficult to predict analytically the heat-transfer rate through annular fins with a step change in thickness when nonlinear phenomena occur on the exposed surfaces. In nuclear applications, radiation also dissipates heat from the fin surface; this is highly nonlinear with respect to the fin surface temperature. Heat is also generated inside the fin, and may be dependent on the temperature.

2.3. Arslanturk C. Performance analysis and optimization of radiating fins with a step change in thickness and variable thermal conductivity

To the best of the authors' knowledge, no analysis of annular stepped fins has been conducted that considers these aspects. This motivated the present study. Based on their ease of fabrication, in this study, ASFs were selected to dissipate heat from surfaces by convection and radiation. Temperature-dependent volumetric heat generation was

analyzed to obtain a generalized formulation. An approximate analysis was proposed to linearize the governing equations and boundary conditions. The linear equations were then solved approximately using a mean-value approach, and modified Bessel functions were used to determine an exact solution. In addition, an exact analysis was carried out, without linearization, using a two steps differential transform method to determine the temperature distribution inside ASFs with heat generation. Since this heat was generated inside the fin, the heat-transfer rate from the fin surface was evaluated using an integral approach over the fin surface. This was established by an integral-differential formulation based on the differential transform method. The fin performance was then estimated for varying thermo physical, geometrical, and heat generation parameters. Both ASFs and ADFs were optimized by maximizing the heat-transfer rate for a given fin volume.

#### 2.4. Kundu B, Lee K S. Analytic solution for heat transfer of wet fins o account of all nonlinearity effects

Kundu and Lee developed an analytical solution for the heat transfer for different shapes of wet longitudinal fins based on the differential transform method while accounting for all nonlinearity effects. Kundu and Lee demonstrated a novel analysis based on the calculus of variation to determine the smallest envelop fin shape for wet fins with a nonlinear move of surface transport. Homotopy perturbation method (HPM) which was recently developed is one of the most successful and efficient method in solving nonlinear equation. In contrast to previously introduced analytic method, Homotopy perturbation method is independent of any small or large parameter.

#### 2.5. Kundu B, Das P K. Optimum profile of thin fins with volumetric heat generation: a unified approach

Kundu and Das analytically determined a fin must be thin to maximize the surface area to volume ratio. Tapered profiles are difficult to fabricate and may be impossible to implement. However, the fin thickness near the tip can be easily reduced in a step-wise manner by adopting a suitable stepped profile. Kundu and Das determined the temperature distribution of a concentric annular fin with a step change in thickness. Under dehumidifying surface condition, Kundu analysed the profile of annular stepped fin (ASF) to determine their performance. This profile was shown to have an improved heat-transfer rate per unit fin volume compared to a constant thickness profile.

#### 2.6. Hanin L, Campo A. New minimum volume straight cooling fin taking into account the length of arc

Hanin and Campo presented an analytic formulation for the optimum profile of straight fin by minimizing the volume of a given amount of heat transfer per unit width, according to their calculations the optimum fin profile is a circular arc, the volume of which is on average seven times smaller than that of optimal fin proposed by Schmidt. All of the above studies used fins with specific geometries, either

with constant or variable fin thickness. To improve the heat transfer rate per unit fin volume, the optimum fin profile or shape can be determined by minimizing the fin volume for a given heat transfer rate. For conduction and convection condition, a criterion for optimal fin was first proposed by Schmidt.

#### 2.7. Torabi M, Yaghoobi H, Kiani M R. Thermal analysis of the convective-radiative fin with a step change in thickness and temperature dependent thermal conductivity

The problem was solved by Torabi et al for non zero absolute zero surrounding temperature using the differential transform methods. The profile shape of stepped fin is similar to that of constant thickness fin. Therefore, such a fin is easy to fabricate than a variable thickness fin. A stepped fin not only makes efficient use of the fin material but also induces turbulent flow over its surface. Thus, the average heat transfer coefficient for fin with stepped surface is always greater than that of fin without stepped surfaces. A stepped fin with a thinner tip effectively utilizes the fin material, as the heat conduction rate is reduced from the base to the tip. Analytical results have been presented for stepped annular fins with linear surface conditions to simplify the calculations. However, it is more difficult to predict analytically the heat transfer rate through annular fin with step change in thickness when nonlinear phenomena occur on the exposed surfaces. In nuclear applications, radiations also dissipate heat from the fin surface; this is highly nonlinear with respect to the fin surface temperature. Heat is also generated inside the fin, and may be dependent on the temperature. To the best of the author's knowledge no analysis of annular stepped fin has been conducted that considers these aspects. This motivated the present study.

### 3. EXPERIMENTAL ANALYSIS

#### 3.1 GEOMETRY OF ASF

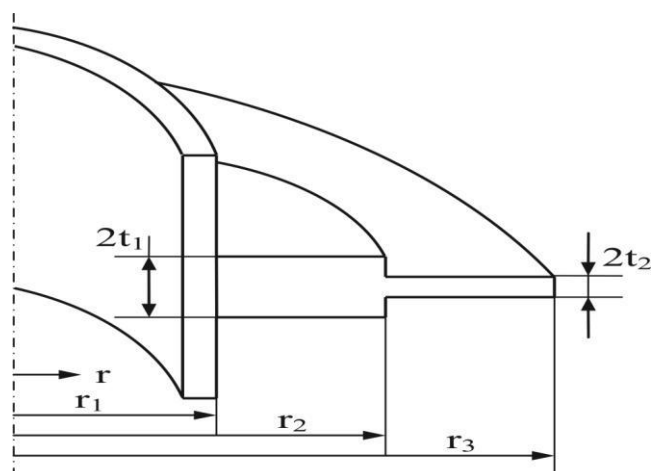

Fig 3.1 Schematic diagram

Where,

$r_1$  = inner radius (mm)

$r_2$  = step radius of an ASF (mm)  $r_3$  =

outer radius (mm)

$2t_1$  = base thickness (mm)

$2t_2$  = tip thickness (mm)

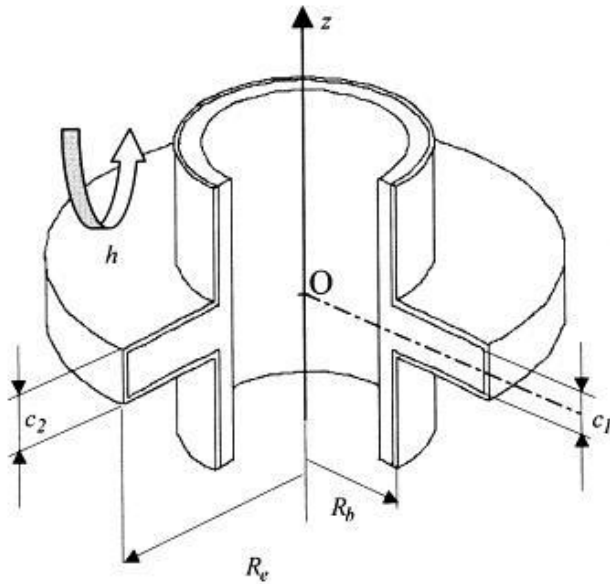

Fig 3.2 Three Dimesional Diagram

3.1.1 Assumption

- > Steady state conditions
- > Constant properties
- > Negligible radiation exchange with surroundings.
- > Uniform heat transfer coefficient, thermal conductivity

3.2 MATERIAL SPECIFICATION AND GEOMETRY

- > Base radius (rb) =25mm
- > Tip radius (rt) =45mm
- > Base thickness (2t1) =15mm
- > Tip thickness (2t2) =7.5mm
- > Length of the fin (rt-rb) =20mm
- > Step radius (ri) =35mm
- > Heat transfer coefficient (h) =10W/m<sup>2</sup>K
- > Thermal conductivity (K) =202W/mK
- > Base temperature (tb) =440K
- > Ambient temperature (T) =300K

3.3 FABRICATION OF ASF AND ADF

- i. Material - Aluminium
- ii. Reason
  - Easily machinable
  - Good corrosion resistance
  - Moderate thermal conductivity
  - Less weight
  - Low cost

- iii. 3D Model ASF

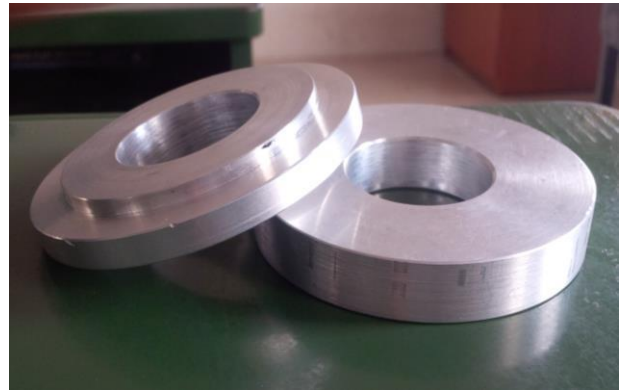

Fig 3.3 Fabricated ASF & ADF

3.4 EXPERIMENTAL SETUP

1. Heating coil (230V,1.1A)
2. K type thermocouple
3. Regulator
4. Multimeter
- 3.5 Fin

Heating coil

Heating coil converts the electricity into heat through the process of resistive or joule heating. Electric current passing through the element encounters resistance, resulting in heating the element.

K type thermocouple

This is the most common thermocouple type that provides the widest operating thermometer range. Type K thermocouples generally will work in most applications because they are nickel based and have good corrosion resistance.

Regulator

The function of regulator is to control the voltage and current and to provide convenient environment. The traditional regulator which are bulky use a resistance having tapes and connected with series.

Multimeter

A multimeter is also known as VOM (Volt-Ohm-Milliammeter), is an electronic measuring instrument that combines several measurement function in one unit. A typical multimeter can measure voltage, current and resistance.

Fin

A fin is a heat transfer component which conduct the heat from a heat source and then dissipate the heat to the surrounding air by convection, radiation or simultaneous convection-radiation.



PHOTOGRAPH



Numerical analysis naturally finds applications in all field of engineering and the physical science, but in the 21<sup>st</sup> century also the life science and even the arts have adopted elements of scientific computation. Before the advent of modern computers numerical methods often depended on hand interpolation in large printed tables.

The overall goal of field of the numerical analysis is the design and analysis of techniques to give approximate but accurate solution to hard problems.

Numerical analysis continues this long tradition of practical mathematical calculations. Much like the Babylonian approximation of the square root of 2, modern numerical analysis does not seek exact answer, because exact answer are often impossible to obtain in practice. Instead, much of numerical analysis is concerned with obtaining approximate solutions while maintaining reasonable bounds on errors.

SOFTWARE

- > Designing - Solidworks 2013
- > Meshing - ANSYS workbench V.15
- > Analyzing - Fluent V.15

4.1 3D MODELLING

ASF

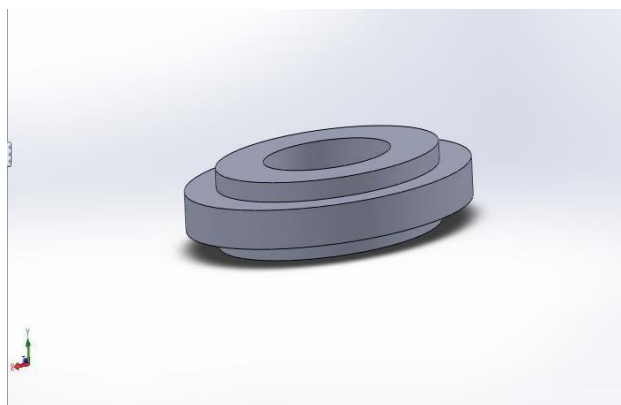

Fig 4.1 Model view of ASF

4. NUMERICAL ANALYSIS  
ADF



Fig 4.2 Model view of ADF

4.2 POST PROCESSING 4.2.1 Temperature contour ASF

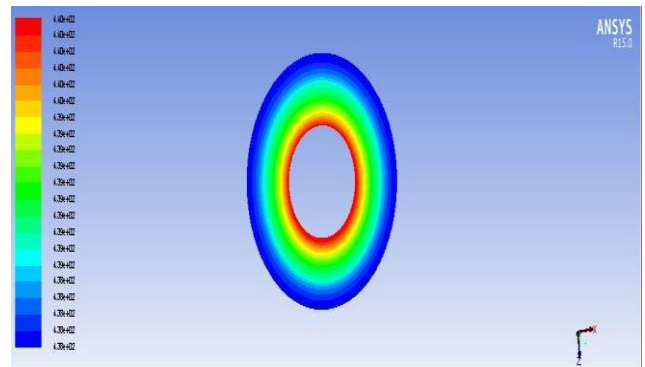

Fig 4.3 Temperature contour of ASF ADF

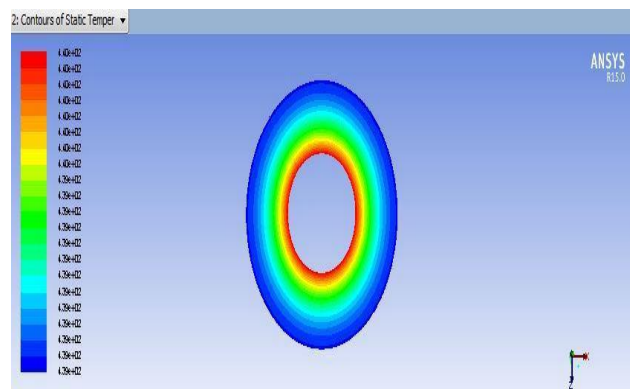

Fig 4.4 Temperature contour of ADF

5 .RESULT AND DISCUSSION

From the experimental analysis the temperature reading shows of the ASF fin shows the better temperature drop after the step radius as compared to ADF fin

From the numerical analysis the heat transfer rate is higher for ASF than that in ADF.

## REFERENCE

- [1] Ganeshkumar, "Heat transfer analysis in annular stepped fin by theoretical and numerical methods". IJERT 2016, 2278:0181 pg 144-149
- [2] Kundu B, Das PK. Performance analysis and optimization of annular fin with a step change in thickness. J Heat transf 2001; 123(3):601-3.
- [3] Torabi M, Yaghoobi H. Two dominant analytical methods for thermal analysis of convective step fin with variable thermal conductivity. J Thero Appl Mech 2013; 51:593-602.
- [4] Arslanturk C. Performance analysis and optimization of radiating fins with a step change in thickness and variable thermal conductivity by homotopy perturbation method. Heat and mass transf 2011; 47:131-8.
- [5] Kundu B, Lee K S. Analytic solution for heat transfer of wet fins on account of all nonlinearity effects. Energy 2012; 41:354-67.
- [6] Kundu B, Das P K. Optimum profile of thin fins with volumetric heat generation: a unified approach. J Heat Transf 2005; 127(8):945-8.
- [7] Hanin L, Campo A. New minimum volume straight cooling fin taking into account the length of arc. Int J Heat Transf 2003; 46(26):5145-52.
- [8] Torabi M, Yaghoobi H, Kiani M R. Thermal analysis of the convective-radiative fin with a step change in thickness and temperature dependent thermal conductivity. J Thero Appl Mech 2013; 51:593-602.