

Design and Realization of RFID based Smart Voting System with Frontal Face Recognition Technique

Mrs. R. Priyadarshini

Assistant professor/ECE department,
Sri Shakthi institute of engineering and technology,
Coimbatore, India.

Ms. D. Shangamithra, Ms. T. Swathi

Ms. G. Subaharini, Mr. L. Sreenivasan,
UG student/ECE,
Sri Shakthi institute of engineering and technology,
Coimbatore, India.

Abstract: The main aspect of democracy of a nation is the VOTE by which people elect their favorite candidate to rule the nation. Intervention of illegal practices will lead the nation to wrong hands. There are several methods adopted by the government to avoid crimes during voting. But the untouched area without proper security is the verification process. This process is still done manually in our country and there is a huge manpower requirement. This paper mainly helps in resolving difficulties and crimes involved in verification process. In this system a database containing the details of the voter, fingerprint and face details are collected prior and stored. The voter is given an RFID card which will serve as a voter ID card for the individual and contains details about the person. During the day of voting the voter will undergo a three level verification process. The voter's card is first read by an RFID reader, the details of the person are displayed on the LCD and then the voter is asked to verify his fingerprint. The fingerprint reader reads the finger print and verifies the fingerprint with already existing database, if the finger print details matches, the next level of verification continues. The voter's face is recognized and matched with the existing database. If all the three levels are matched then the door of ballot booth opens for the voter to cast the vote. If not the voter is barred from voting. Also the results are simultaneously displayed on the monitor. This secured verification process prevents proxies, political party intervention and other crime activities during the Election Day.

Keywords — *ATMEGA328p, fingerprint module, servo motor, RFID card and reader, Raspberry pi 3b and camera*

I. INTRODUCTION:

The democracy of any nation lies in VOTE the people cast to elect their leaders. But this system despite high security is still suffering from various issues mainly during verification process and the manpower requirement during that process is large. There are chances of intervention of political parties and human errors in this process but yet there are no best solutions to overcome this problem. If this problem is not overcome then it might lead the nation into wrong hands. The security and manpower requirement during the verification process can be overcome by the method used in this paper.

II EXISTING SYSTEM:

There are several methods available to carry out verification process. Out of several processes biometric verification is the most secured process. But in the existing systems only either of the biometrics are used. The security cannot be ensured in these processes. Also these methods have not been implemented successfully.

III PROPOSED SYSTEM:

The proposed system is based on the verification process on the Election Day. The system has a database which is pre-recorded and contains the details about the individuals who are above 18 years. These details include the biometric and personal details. The voter ID card is replaced with a RFID card which serves as an access to the individual on the day of voting. During the day of voting the voter undergoes a three step verification process. The first step is one in wherein the voter has to show his RFID card and it is read by a RFID reader module. The reader module senses the card and displays the details of the individual on the LCD screen. Once after the details are displayed the voter is asked to place his/her registered finger on the fingerprint sensor. The sensor module verifies the fingerprint with the existing database and permits the user to next level of verification process if the details matches else the LCD displays "wrong user". Once after the fingerprint matches, the camera turns on for the face recognition and captures the image of the person and matches it with the existing database. If the images also matches then the door of ballot booth opens for the voter to cast his vote and the votes are simultaneously on the monitor. Thus this process provides a much secured three level verification process and the illegal practices during the day of voting are also avoided.

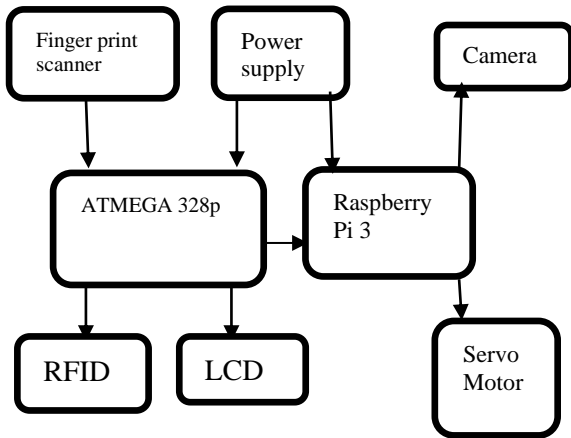

Fig.1.Block diagram

IV HARDWARE DESCRIPTION:

a) *Raspberry pi3:*

Raspberry pi 3 model B is the earliest model of third-generation raspberry pi. It is a 1.2GHZ Broadcom BCM2837 64 bit CPU. It has four USB 2 ports and CSI camera port for connecting a raspberry pi camera. A micro SD port is available for loading OS and for storing data. These features make this pi 3 to be one of the efficient controllers. The image processing is done with the help of this controller as image has to be in a high clarity. The ATMEGA 329p is also interfaced to this processor. Also pi enables the capturing and verifying the captured image very quickly than other processors. Pi has the ability to work as normal computer. The language which is used in Pi is python.



Fig.2.Raspberry pi3

b) *ATMEGA 328p:*

The second controller used in this system is ATMEGA328p. This has a high performance, low power CMOS 8 bit controller. It is based on RISC architecture. It has 28 pins and can be efficiently used to interface several devices. In this system it controls the RFID module, LCD display and the fingerprint sensor. It controls three devices namely the fingerprint scanner, RFID module and LCD. The controller is capable of executing multiple processes at the same time with the same speed. It is interfaced with raspberry pi.



Fig.3.ATMEGA 328P

c) *RFID module:*

Radio Frequency Identification (RFID) is a wireless identification technology that uses electromagnetic fields of radio frequency range to identify RFID tags. It is used for identification of people, object etc. The RFID tag contains a radio antenna mounted on a substrate which carries 12 bytes unique identification number. The reader module is used to read unique ID from tags. Whenever the RFID tags comes into range, the reader reads its unique ID and transmits it serially to the microcontroller. Data can be read or write from the cards because they consists of EEPROM. In the same way in this system the voter ID card which is modified as RFID card is contains personal details of the individual stored in it. Once the reader reads the tags, the details are displayed on the LCD.



Fig.4.RFID reader module



Fig.5.RFID card

d) *R307 Fingerprint module:*

R307 module consist of optical fingerprint sensor and enables independent fingerprint collection, fingerprint registration, 1:1 fingerprint comparison and 1:N fingerprint search. It is small in size and has an ultra-low power consumption, high-performance fingerprint alignment algorithm, high-capacity FLASH chips. It can directly interface with 3.3 or 5v. It has a fingerprint

image input time <0.3 seconds and has a very low search time <1.0 seconds and has a storage capacity of about 1000 pieces. In this system the fingerprint sensor is used to capture an image up to resolution 500 dpi and register the fingerprints for future use.



Fig.6.Fingerprint scanner

e) **LCD :**

A liquid crystal display is a flat panel display or other electronically modulated optical device that uses the light modulating properties of liquid crystals combined with polarizers. Liquid Crystal Display technology works by blocking of light. They do not emit light directly but instead uses a backlight or reflector to produce images in a monocular. This project uses the LCD display to establish the details of an individual and producing a confirmation message.

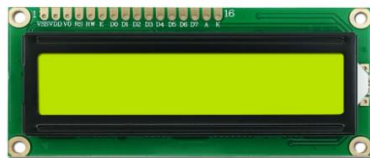

Fig.7.LCD

f) **Servomotor:**

Servomotor is an electrical device which can push or rotate objects with good precision. To rotate an object at specific angle or distance servomotors are helpful. Servomotors are small in size and have a built in control circuitry and good power for their size. In this system servo motor is used to control the opening and closing of ballot door. The position of servo motor is decided by electrical pulse and its circuitry and is placed beside the motor.



Fig.8.Servomotor

V SOFTWARE DESCRIPTION:

The software used for face recognition is Object Detection using Haar feature-based cascade classifiers is an effective object detection method. It is a machine learning based approach where a cascade function is trained from a lot of positive and negative images. It is then used to detect objects in other images. Initially, the algorithm needs a lot of positive images (images of faces) and negative images (images without faces) to train the classifier. Then we need to extract features from it. The features includes face pattern. For each feature it finds the best threshold which will classify the faces to positive and negative images. The features with minimum error rate which means they are the features that best classifies the face and non-face images. Each image is given an equal weight in beginning. After each classification weights of miss classified images are increased. Then again same process is done. The process is continued until required accuracy or error rate is achieved. The concept of cascade of classifiers group the features into different stages of classifiers and apply one by one.

Haar Cascade detection in Open CV:

Open CV comes with a trainer as well as a detector. It contains many pre trained classifiers for eyes, face, smile etc. First we need to load the required XML classifiers and then load our input image in grayscale mode. If the faces are found it returns the position of detected faces as rectangle. Once we get the location we can create a ROI for face and eye detection. There are three different processes carried out during face recognition. First the image of the person is captured which uses a dataset program running at the background.

Once the program is executed the camera captures image of a person in all possible directions by creating a rectangular block around the face. The captured images are used to train the classifier for face recognition process to be completed. During face recognition phase the, a separate program runs to compare the original face in the classifier and the captured face. The use age of cascade classifier enables to produce effective face recognition and detection mechanism.

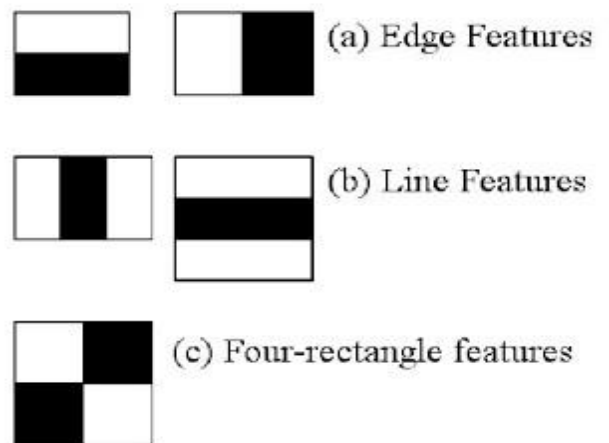

Fig .9. Feature extraction

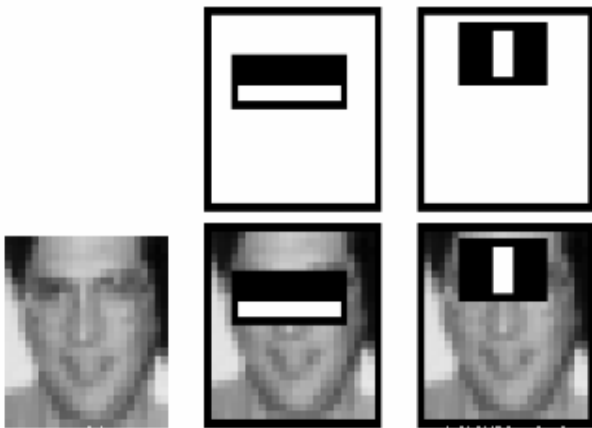

Fig .10. Training image

VI FLOW CHART

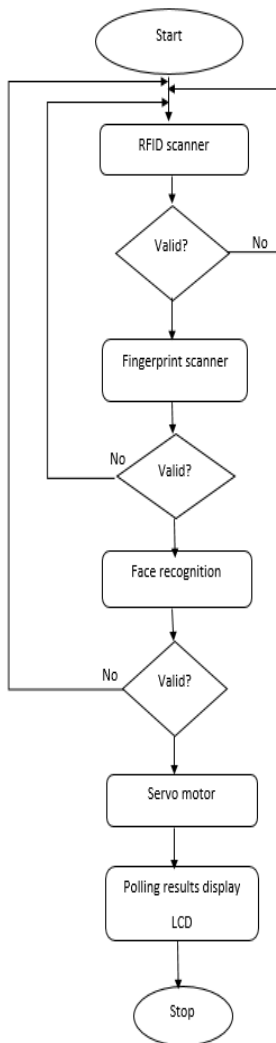

Fig.11. Flow chart

VII RESULTS:

The system verifies the details which are stored in the database which includes face and fingerprint details. The user details are verified in a step by step process and finally if the details are matched the door opens for the voters to cast their vote. The final polling results are displayed simultaneously on the monitor.

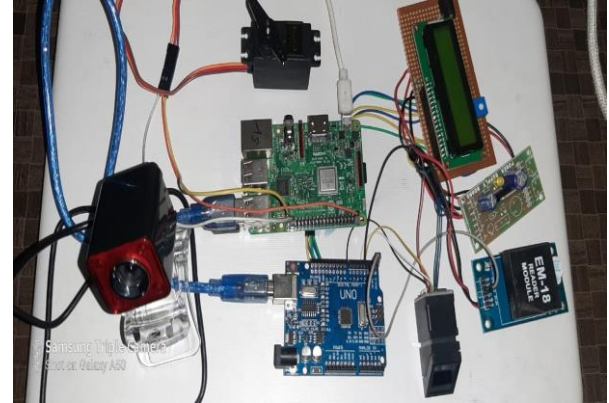

Fig.12. Experimental setup

The Fig 12 shows the experimental setup which contains all the devices connected and interfaced with one another .The picture shows the connection of finger print scanner, RFID reader module and LCD with the arduino. Whereas the camera and servomotor is connected to the raspberry pi3.



Fig.13. Initiation process

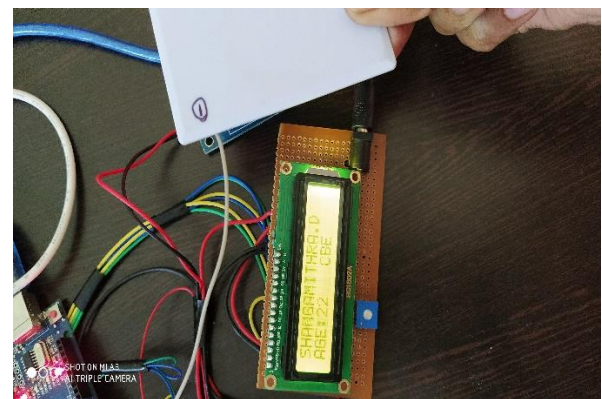

Fig.14. RFID card verification

In the above Fig.13 shows a LCD screen which requests the user to show their RFID voter card. Which is followed by RFID card verification, Fig.14 shows the verification of user details and also the screen displaying the details of the individual.



Fig.15 fingerprint section

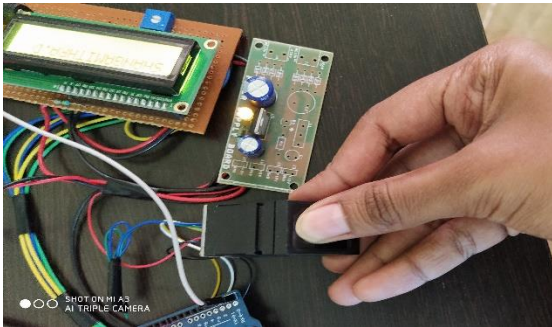

Fig.16.Fingerprint verification

The Fig.15 gives a message for the voter to place their registered finger for fingerprint verification. The matching of fingerprint is ensured in Fig.16 where a user places the finger on the scanner and the scanned result are displayed on the screen. The confirmation of fingerprint is given such that the user's name displays on the LCD screen.

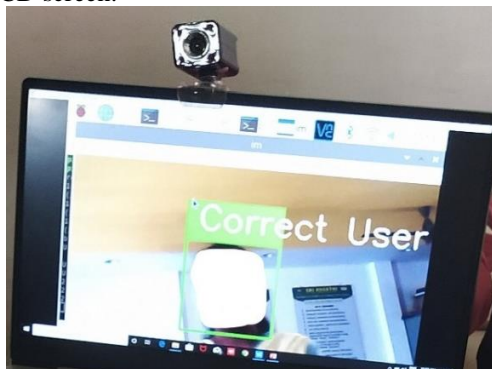

Fig.17.Face recognition

Once after the fingerprint verification is over the camera opens for face recognition and the user's face is evaluated. Based on the accuracy of valuation the results are displayed on the monitor as valid or invalid user. Then the servo motor rotates and opens the door for polling.

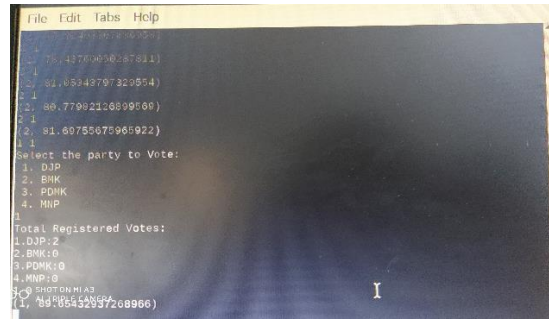

Fig.18. Polling results

The Fig.18 displays the polling results simultaneously as voters cast their vote. The counts are increased for each party respectively.

VIII ADVANTAGES:

- 1 .Simple process
2. Human involvement is minimized.
3. Ensures good security.
4. Reduced manpower requirement.

IX APPLICATIONS:

1. It is mainly used in verification process during elections.
2. It can also be used in areas where verification of an individual plays a vital role

X CONCLUSION:

The project is found to be very helpful in overcoming the difficulties faced during verification process. Also it efficiently uses both the biometrics of a person which is fingerprint and face. This serves to be an efficient method to reduce manpower requirement and other illegal activities. Also it eliminates manual errors incurred during verification and displays the polling results at the end. The process can be extended to help government during election and reduce fraudulence to a great extent.

IX REFERENCES:

1. Paul viola et al, "rapid object detection using a boosted cascade of simple features", 2001 IEEE.
2. S.Selvarani et al., "Automatic Identification and Detection of Altered Fingerprints", 2014 International Conference on Intelligent Computing Applications.
3. Dichou Karima, et al., "An Improved Electronic Voting Machine Using a Microcontroller and a Smart Card", 2014 9th International Design and Test Symposium.
4. Ms.AshwiniAshok et al., "Mobile Based Facial Recognition Using OTP Verification for Voting System", 2015, IEEE International Advance Computing.
5. Kirthikapriya V, "Arduino based smart electronic voting machine", 2017, ICEI.
6. Bhuvanapriya .R et al., "smart voting", 2017 ICCT.
7. Rahil rezwan et al., "Biometrically secured electronic voting machine", 2017, IEEE.
8. Ayman A. Wazwaz et al, "Raspberry pi and computer based face detection and recognition system", 2018, International conference on computer and technology applications.
9. Jagtap AM et al., "electronic voting system using biometrics, raspberry pi and TFT", 2019, ICOEI.
10. Md. Mahiuddin, "Design a secure voting system using smart card and iris recognition", 2019 ECCE.