

Design and Implementation of Smoke Intensity Measuring by Testbeds Using Optoelectronics

A. Arockia Faustine¹, S. R. Vigneshwari²

¹PG STUDENT, ²ASSISTANT PROFESSOR

Department of Electronics And Communication Engineering
Parisutham Institute of Technology And Science, Thanjavur, Tamil Nadu.

Abstract- The main plan here is to regulate fireplace in any trade and domestic space in an exceedingly very price effective means with the measurement of smoke from burning materials. During this technique the attenuation of sunshine by smoke, and smoke amount is so reported in terms of optical intensity instead of light-weight absorbance or coefficient. Experiments are performed on a spread of building end materials underneath each flaming and no flaming (smoldering) conditions, and also the results square measure rumored in terms of maximum rate of smoke accumulation and also the timeperiod to reach an arbitrary critical smoke level.

Key words: Rayleigh scattering, led (or) laser, free space transmission.

I. INTRODUCTION

A wildfire is a large-scale natural combustion process that consumes various ages, sizes, and types of flora growing in outdoor area. Forest fire leads to large amounts of air pollutants that should be considered when trying to relate emissions to air quality. The size and intensity of the forest fire almost depends on the earth environmental conditions, the variety of vegetation involved and their moisture content present in the air, and the weight of consumable fuel per area. If the forest fire releases large amount of energy within particular duration it causes drying of green and also material get burning as well. The burning of different materials will cause several changes to the environment. The complete combustion of wildland fuels (forests, grasslands, wetlands) require a heat flux and also needs large amount of oxygen to ignite and time consumption is large. The size and quantity of forest fire materials, the environmental conditions and fossil features interacts to modify behaviour of burning material and also depends on combustion efficiency during its lifetime.

When accidental fires occur, the smoke generated is often considered to represent the major life danger to the building occupants. Although large concentrations of carbon monoxide and perhaps other toxic products may be present, the obscuration of vision by dense smoke often prevents the direct and logical escape of occupants, or rescue by

firemen, during the few minutes available prior to spread of the fire, and the onset of lethal conditions. The smoke-limiting requirements in current building codes have been established in an attempt to regulate and to reduce the potential light to obscuration hazard from smoke generated by the interior building finish materials applied to walls, ceilings, and floors. These requirements are commonly based on the results from tests devised principally for measuring comparative surface flammability. Unfortunately the relationship between the results of such tests and the visual-obscuring qualities of smoke are not well established. In a recent study, an attempt was made to relate the "tunnel" smoke density ratings for a variety of building materials with visual and photoelectric observations in a room in which the smoke from the tunnel was collected. The immediate objectives of the present study are to investigate the suitability of a laboratory method to measure smoke quantity under prescribed and standardized exposure conditions and to evaluate the appropriate optical properties of smokes which obstruct human vision in building fires, without regard to the chemical nature of the smoke or the fundamental processes of its generation.

II. LITERATURE SURVEY

[1] Smoke detection becomes a lot of and more appealing due to its necessary application in hearth protection. During this paper counsel some additional universal options, like the dynamical unevenness of density distribution and also the dynamical irregularities of the contour of smoke. So as to integrate these options fairly and gain a coffee generalization error rate, we tend to propose a support vector machine primarily based smoke detector. The feature set and also the classifier will be utilized in numerous smoke cases contrary to the restricted applications of alternative ways. Experimental results on completely different sorts of smoke in numerous scenes show that the formula is reliable and effective.

Support vector machines square measure supervised learning techniques, recently developed within the framework of

applied mathematics learning theory, that are receiving nice attention from the machine learning community. SVMs may also be seen as special implementation of VC-dimension and min-imitation of structural risk theories. As a result of the strong performance with regard to thin and noise knowledge, SVMs are used successfully in an exceedingly sizable amount of applications, as well as text characterization, face recognition and bioinformatics.

Some additional universal smoke options and introduce SVMs as learning machine to attain considerable performance in numerous scenes. Additionally, if we tend to choose the weights proportion of positive samples and negative and swish the results exploitation multi-frame data.

[2]In in depth facilities like port facilities, chemical plants, and power stations, it's necessary to find a fireplace early and positively. The aim of this paper is to gift a brand new smoke detection technique in open areas, as smoke is taken into account as a major signal of the fireplace. It's assumed that the camera observance the scene of the open space is stationary. Since smoke doesn't keep stationary form or image options like edges, its troublesome apply ordinal image process techniques like the sting or contour detection directly. During this paper, a novel technique of the smoke detection in a picture sequence, within which we tend to combines the many pictures techniques to find smoke is projected. It applied to pictures of open areas below general environmental conditions. First, moving objects square measure detected from gray-scale image sequences, then the noise is removed with the image binarization and also the morphological operation. What is more, since the smoke pattern should be examined, the smoke feature is extracted with the feel analysis. Then, to get the ultimate results of the projected technique.

The smoke detection in image sequences. During this technique mix some image process ways below concerns of characteristic properties of smoke. First off extract regions of moving objects, that square measure candidates of smoke regions. During this process, characteristic properties of smoke like a growth speed and a non-stationary form was thought-about. Then, get a live of the similarity between these regions and smoke regions on the idea of texture analysis and a property as statistic knowledge. For the analysis, a perfect smoke was ready which area unit manually elite smoke regions from image sequences. And a similarity live between the extracted regions and smoke is outlined supported texture options of ideal smoke. Using this, smoke detection on the image sequence is proceeded. That everyone pictures utilized in this paper area unit gray-scale. A completely unique technique for police work smoke in image sequences is projected. Within the projected technique, some image process techniques like image subtraction, binarization, and morphological operation, to estimate moving object regions in pictures. The detector operate used

supported the feel options of the smoke region, and additionally accumulate the values of this operate regarding time to get rid of no-smoke region. Victimisation this detector, the detection of smoke in image sequences was proceed. Though there exist little or massive moving objects within the image sequences, the detector doesn't affected except the moving objects have terribly similar characteristic properties to smoke's. Experimental results show the effectiveness of the projected technique. There stay some issues for any works. We'd like an additional correct estimation of the smoke region because the results of Experiment a pair of shows the limitation of the detection. To unravel this drawback, it'll be helpful victimisation not solely gray-scale however additionally colour data of pictures. Another drawback is to observe the correct point data of smoke regions. If smoke is detected, data of Feret's regions is helpful to estimate point and region data of smoke.

[3]Point smoke density mensuration system plays the most necessary role whereas calibrating hearth detector. Primarily based on dimmer principle and electricity technology, a measurement system is meant during this paper. Because the emitting device, infrared semiconductor diode provides lightweight into the smoke measured. Corresponding driving circuit is meant to manage On/Off of the semiconductor diode and supply constant current. Because the receiving device, photodiode is chosen to convert actinic ray into weak current. The acquisition circuit converts the weak current into customary voltage to be measured. Because the central unit, Single Chip personal computer (SCM) acquires the quality voltage and communicate with computer by RS485 interface. The system designed possesses such benefits as high accuracy, more flexibility, lower power consume.

Smoke particle measured, actinic ray are going to be sensitive to the smoke density supported Rayleigh Scattering theory. So, infrared semiconductor diode and infrared photodiode area unit chosen because the emitting device and therefore the receiving device severally. Infrared semiconductor diode, Driving, Circuit, acquisition, Infrared Photodiode, SCU every unit performs completely different operate within the method of smoke mensuration. Infrared semiconductor diode can emit actinic ray which is able to be disturbed by the smoke measured. Driving circuit can give necessary power to drive. The semiconductor diode causation infrared light, which might be controlled by the central SCU. Infrared photodiode can receive actinic radiation when the disturbance of the smoke measured and convert it into weak current. Learning circuit can perform the conversion and amplifying. Then it offer appropriate signal to the central SCU. As the central unite, SCU can management the driving circuit and acquire signal from the receiving photodiode. RS485 interface can convert the no heritable signal into 485

customary differential signals that appropriate for remote transmission to computer.

A point smoke density measure system was designed supported electricity during this paper. It may accomplished the calibrating perform target towards fireplace detector with success. It possess such sensible performances as quick response, flexibility, low power consume so on. It's one in all the perfect solutions whereas calibrating fireplace detector.

[4]The demonstrate a way for microparticle detection with associate optical microfiber (OM). Once a microparticle adheres to the uniform waist region of associate OM, the transmitted loss of OM can increase as a result of the temporary field perturbation. The extra loss of OM, caused by the adhered microparticle with totally different refractive indices and diameters, has been researched and simulated supported the temporary theory. It through an experiment demonstrate the likelihood of the tactic with an easy setup. Mud and corundum microparticles square measure detected. Experimental results have shown that the diameter of mud microparticle and therefore the variety of adhered corundum microparticles, are often calculable by measurement the extra loss of the sensing OM. MICROPARTICLE contaminants create a series of great issues in producing processes, the refining industry, water purification, and high-octane optical maser transmission. The common strategies to discover small particles, like laser-scattering particle counters, particle detection Integrated in a very dielectrophoretic lab-on-a-chip quartz balance (QCM) thin-film bulk undulation resonators (FBARs) and small mechanical device (MEMS) resonators square measure arduous to satisfy the demand. Optical microfibers (OMs) have recently become progressively enticing thanks to their special optical properties that embody convenient property to traditional glass fiber parts, robust optical confinement, sensible flexibility, and manageable temporary fields. OM has been wide studied in sensing fields, like the determination of humidness, index of refraction (RI), UV light, section modulator and current. Evanescent field round the OM, we tend to propose and investigate the likelihood to discover the given material small particles adhered to the sensing OM, by simply observance the extra loss. Through measurement the amount of the adhered particles, the particle contaminants existing within the whole setting are often calculable. we tend to believe this technique is beneficial for real time detection of small particle in special atmosphere. In conclusion, a way to discover microparticle with OM is here planned and by experimentation incontestable. MICROPARTICLE DETECTION WITH OMs adhered to the surface of OM disturb its impermanent field, that causes an excellent deal of scattering and an extra loss of the sensing OM. Theoretical study shows the extra loss of the sensing OM is intensively with relevancy index of refraction and size of particles. For a given material particle, its size will be

evaluated through mensuration the extra loss. During this means, the quantity of adhered microparticles, whose material and size square measure illustrious, also can be obtained. Mud particle detection and corundum particle detection were performed to demonstrate the likelihood of microparticle detection with OM. Experimental results were essentially in accordance with those of the simulation. The OM particle device will be accustomed sense particle mass on the order of sub-pg., and to observe particle contaminants in tidy vacuum house and high-energy optical device transmission systems. In sensible, the 2 cone like regions of OM ought to be shielded from contaminants, as an example, coated with Teflon. Advanced things, like 2 adjacent particles, technique completely differentiate to tell apart} different material, and microparticles detection at totally different operational wavelengths, ought to be any studied.

[5]One challenge featured by the in-home junction rectifier (LED) optical wireless communication is that the optical noises. Here, 1st by experimentation characterize the result of optical background signal to the performance of the LED optical wireless channel. It demonstrate victimization Manchester secret writing for the LED to mitigate the optical noise. No adaptation watching, feedback, or optical filtering is needed. The theoretical and numerical analysis of Manchester secret writing method to mitigate the optical background signal is provided. Our experimental result shows that Manchester secret writing will considerably eliminate optical noise generated by the AC-LED operated at five hundred GkHz and fluorescent lightweight.

The Manchester signal will be generated by victimization exclusive-or (XOR) operation of the initial NRZ knowledge and also the clock. This signal is applied to the LED supply. At the receiver (Rx), the received Manchester signal are going to be power divided into 2 components. One half are going to be half-bit delayed, because the received Manchester signal can then cipher its half-bit delayed signal victimization offline digital signal process (DSP) or victimization commercially offered totally different electronic equipment for secret writing. Finally, bit-error-rate (BER) call will be created at the quantity, indicating that the received signal will be properly decoded once it's compared with the initial NRZ signal logic.

The Manchester secret writing has vital result for signal quality improvement below the interference especially frequency bands. The Manchester secret writing is additionally a line code that has synchronization, thus it's advantageous to use it in communications. Besides the Manchester secret writing, different forward error correction (FEC) techniques also can be used because the second layer of secret writing to any enhance the transmission performance. During this experiment, no adaptation watching, feedback, or optical filtering was needed.

III. EXISTING SYSTEM

Smoke is detected using SUPPORT VECTOR MACHINE. The size of the micro particle are detected using OPTICLE MICROFIBER. Video camera based smoke detectors Wired and fixed type of smoke detectors the proposed wildfire detection approach includes two distinct algorithms: Algorithm A is designed to segment smoke clouds in every frame of surveillance frame sequences, and Algorithm B is designed to raise an alarm in the presence of smoke clouds by evaluating the characteristics of single frames. These algorithms can be divided into the same steps. First, a set of features describing different physical characteristics of the smoke clouds (related to the color, shape, and evolution during the time) is extracted. Then, computational intelligence techniques are used to classify every frame as "smoke" or "non smoke." Feature selection techniques are also used in order to reduce the computational time.

IV. PROPOSED SYSTEM

Detecting smoke intensity using optoelectronics. Principle of **Rayleigh scattering**. This paper presented a new approach for the detection of wildfire smoke clouds from low-quality frame sequences, together with a new technique for the simulation of smoke frame sequences. The smoke detection approach is designed in order to work in real-time applications with off-the-shelf hardware and to be robust to different environmental conditions. It is based on computational intelligence techniques and can classify every pixel (Algorithm A) or frame (Algorithm B) as "smoke" or "non smoke." The proposed technique for the simulation of smoke frame sequences is designed to compute big data sets of simulated wildfires in different environments and weather conditions, which should be used to train and test visual fire detection methods. The technique is based on the lattice Boltzmann method, is able to introduce the effects of the wind and buoyancy, and permits to simulate adverse environmental conditions. The performance evaluation of the proposed smoke detection approach was carried out by using both real and simulated smoke frame sequences. Moreover, we evaluated the robustness of the approach to different parameter configurations, the possibility to tune the sensibility to false alarms, and the accuracy obtained by applying feature reduction techniques. Compared with other methods in the literature on data sets composed by real frame sequences, the proposed smoke detection approach obtained accurate results on a greater number of environments and weather conditions. The obtained results are satisfactory and suggest that the approach can be effectively used in different applicative contexts. We used two procedures to validate the

method proposed for the simulation of synthetic smoke frame sequences. First, we visually compared the obtained results with real wildfire frame sequences. Then, we compared the performances of the proposed smoke segmentation algorithm on both simulated and real frame sequences. To obtain results showed that the simulation method is able to obtain realistic smoke clouds in all the evaluated environmental scenarios. Moreover, we experimentally observed that the use of simulated frame sequences can effectively increase the accuracy and generalization capability of the proposed wildfire smoke detection approach when tested on real frame sequences.

A. SYSTEM OVERVIEW:

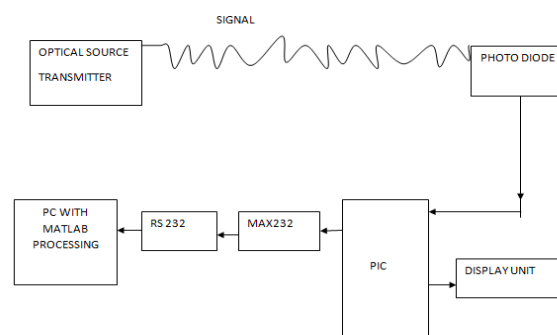

Fig.1 With Out Smoke

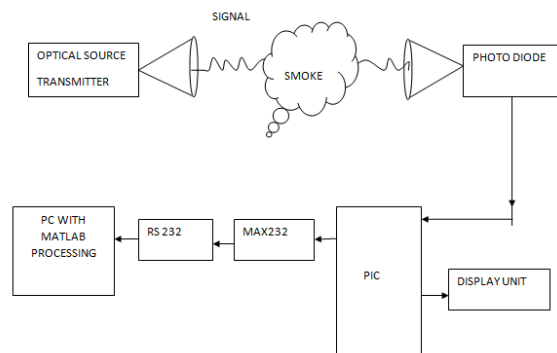

Fig.2 with smoke

Based on the dimmer principle and Rayleigh scattering principle the intensity of light when it passes through the smoke was calculated. Under normal condition, receiving device will receive light source from the emitting device without any disturbance of smoke. While smoke into the measurement space, light is interfered by it. So, the receiving device will receive less light which could be measured by the system designed. From the energy losses, smoke density could be measured.

In the measurement space, smoke particle will distribute in wide range. Its characteristic is not stable which easily cause

light scattering. While smoke particle's diameter is between 0.5 μ m and 1 μ m, it is consistent with Rayleigh scattering.

Light scattering is a useful technique for detecting the presence of small quantities of smoke, particularly for particles which are not readily accessible or where particle size determination is desired. Scattering measurements are generally limited to particles whose size is of the order of the wavelength of visible light. However, where the object is the measurement of smoke as it relates to visibility, the light attenuation method appears to be the most direct and practical approach.

B. Dynamic Time Warping Algorithm:

DTW could be a well-known technique to find associate best Alignment between 2 given (time-dependent) sequences under bound restrictions. Intuitively, the sequences square measure crooked in a nonlinear fashion to match one another. Originally, DTW has been accustomed compare totally different speech patterns in automatic speech recognition. In fields like data processing and information retrieval, DTW has been with success applied to automatically deal with time deformations and totally different speeds associated with time-dependent knowledge.

C. intensity calculation:

By using DTW algorithm to find the difference between two sequences which is obtain by with smoke and without smoke transmission. The Smoke intensity is obtained by the ratio of I(intensity of received signal without smoke) and I₀ (intensity of received signal with smoke). The different between the two signals are shown in graph using MATLAB software.

V. CONCLUSION:

Optoelectronics principle is used in this paper .For future this techniques can be used for measuring intensities of different sources such as snowfall, temperature, humidity etc...If the intensity of the smoke is stored in database we can find what material is to be burning. Especially for long range transmission of data this techniques helps in effective data transmission .It can also used to get clear satellite image instead of image processing technique

REFERENCES

- [1] **Visual-based Smoke Detection using Support Vector Machine**, Feng Chen, Jing Yang, Weidong Zhang, 2008
- [2] **Smoke detection in open areas using its texture features and time series properties** Akihiro Nakamura, Fujio Kurokawa, Hidenori Maruta, 2009
- [3] **Point Smoke Density Measurement System Design based on Photoelectricity** Tao Xu, Xiaodong Zhang, Yanjun Lu. 2011
- [4] **Microparticle Detection With Optical Microfibers** Xueliang Zhang, Zhengtong Wei, Zhangqi Song, Zhou Meng.
- [5] **Mitigation of Optical Background Noise in Light-Emitting Diode (LED) Optical Wireless Communication Systems** C. W. Chow, P. Y. Huang, Y. F. Liu, C. H. Yeh, 2013